

Low power Battery fuel gauge IC for Li-ion battery

MM8118W02LFE

OUTLINE

MM8118W is a battery fuel gauge IC for Li-ion battery and Li-polymer battery. This IC achieves ultra-low power consumption and is best FG for wearables whose battery capacity is small. Its small CSP package is also best for small products on which small footprint is preferable.

This IC measures temperature, voltage, and current with high-precision delta-sigma AD converter, integrates current value both at discharging and charging, and performs capacitance correction based on the measurement value and specific battery characteristics parameter. Thus the IC achieves excellent management ability for battery power.

MM8118W provides several features to make battery use safe and secure. Battery degradation detection which is based on capacitance change is available. And this IC has features for notification of these information.

MM8118W can be implemented at both of host-side and battery-side.

FEATURES

- High accuracy current/voltage measurement

Current and voltage value are measured by high accuracy 16bit delta-sigma AD converter.
The voltage resolution is 1mV and the current resolution is 1mA or 0.1mA (selectable).

- High accuracy battery power management

Battery power is based on integration of periodically-measured current and the value is corrected with open voltage(OCV) and battery characteristics parameters. The battery power is managed so as to minimize the error constantly.

- Ultra-low power consumption

The power-consumption is reduced significantly by long interval periodic fuel gauging which executes ADC and calculation every 60 seconds at no current flow. (for Standard setting)

- Battery degradation monitor

Battery total capacitance is measured periodically and status of capacitance change is monitored.

PACKAGE

WLCSP-15A

PIN CONFIGURATION

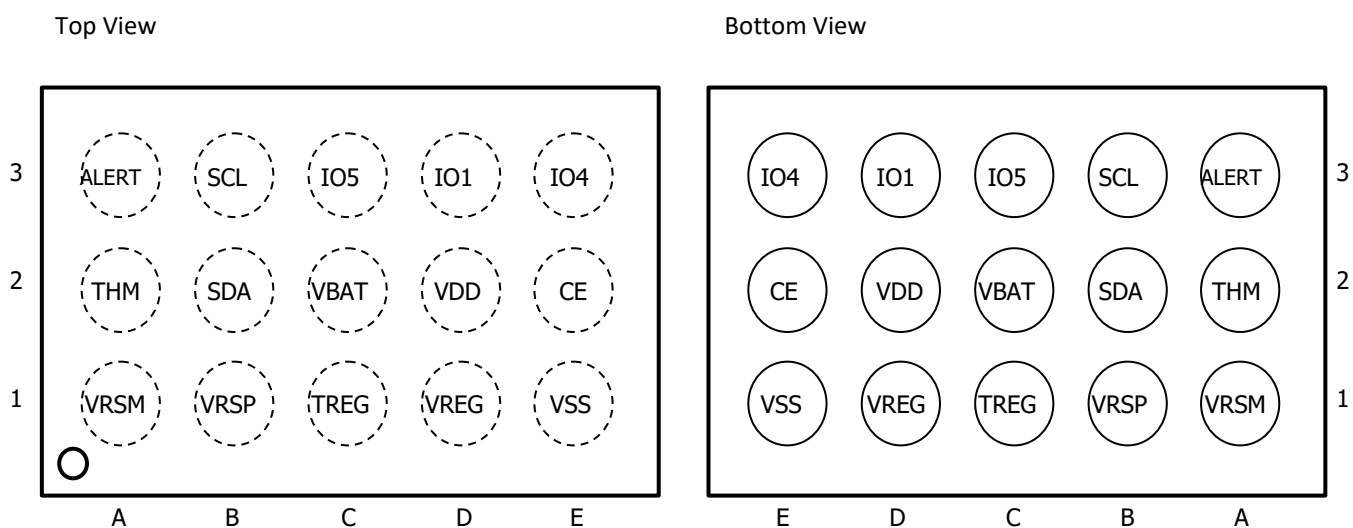

TERMINAL EXPLANATIONS

PIN No.	IN/OUT	SYMBOL	FUNCTION
A1	IN	VRSM	Current sensor input pin
A2	IN	THM	Thermistor input pin
A3	OUT	ALERT	ALERT output pin (Open Drain output)
B1	IN	VRSP	Current sensor input pin
B2	IN/OUT	SDA	I2C data input/output pin
B3	IN/OUT	SCL	I2C clock input/output
C1	OUT	TREG	Regulator output pin for thermistor
C2	IN	VBAT	Voltage sensor input pin
C3	IN/OUT	IO5	General purpose input / output pin (Open Drain output)
D1	OUT	VREG	Regulator output pin
D2	-	VDD	Power supply pin
D3	IN/OUT	IO1	General purpose input / output pin (Push Pull output)
E1	-	VSS	Power supply pin
E2	IN	CE	Chip enable pin. When not using, input VDD.
E3	IN/OUT	IO4	General purpose input / output pin (Push Pull output)

ABSOLUTE MAXIMUM RATINGS

(Ta=25°C, unless otherwise specified)

ITEM	SYMBOL	MIN.	MAX.	UNIT
Supply voltage	VDD	-0.3	6.0	V
Input voltage	VIN	-0.3	6.0	V
Input voltage to CE	VIN2	-0.3	VDD+0.3	V
Input voltage to THM	VIN3	-0.3	VDD+0.3	V
Regulator terminal voltage	VREG	-0.3	2.2	V
Regulator terminal voltage for thermistor	TREG	-0.3	2.2	V
Input voltage to VRSM and VRSP	VI	-0.3	2.2	V
Storage temperature	Tstg	-40	125	°C

RECOMMENDED OPERATING CONDITIONS

ITEM	SYMBOL	MIN.	MAX.	UNIT
Operating ambient temperature	Topr	-20	85	°C
Operating voltage	Vop	2.5	5.5	V

ELECTRICAL CHARACTERISTICS

(Unless otherwise specified, Vdd=3.6V, Topr=25°C)

PARAMETER	SYMBOL	CONDITIONS	MIN.	TYP.	MAX.	UNIT	*1
Normal mode current consumption	Inor		-	30.5	-	μA	T1
		*2	-	31.0	-		
		Topr=-20~85°C *2	-	-	48.0		
Sleep mode current consumption	Islp	Interval 20s	-	21.8	-	μA	T1
		Interval 20s *2	-	22.0	-		
		Interval 20s Topr=-20~85°C *2	-	-	33.0		
FullSleep mode current consumption	Ifslp	Interval 60s	-	6.3	-	μA	T1
		Interval 60s *2	-	6.3	-		
		Interval 60s Topr=-20~85°C *2	-	-	23.0		
Standby mode current consumption	Istb		-	5.5	-	μA	T1
		Topr=-20~85°C	-	-	20.0		
Shutdown mode current consumption	Isdn		-	0.36	1.0	μA	T1

*1 The test circuit symbols.

*2 Thermistor esister are 100kΩ and external resister are 100kΩ.

(Ta=25°C, unless otherwise specified)

PARAMETER	SYMBOL	CONDITIONS	MIN.	TYP.	MAX.	UNIT	*3
Supplied voltage	VDD		2.5	-	5.5	V	-
(SCL, SDA, ALERT, IO1, IO4, CE) Data I/O pin voltage range	VIO		-0.3	-	VDD+0.3	V	-
(IO5) Data I/O pin voltage range	VIO2		-0.3	-	5.5	V	-
Oscillation frequency 1	fosc1	Ta=-20~85°C	-	2000.0	-	kHz	T2
Oscillation frequency 2	fosc2	Ta=-20~85°C	-	32.768	-	kHz	T2
Current sensor input range	Irng		-48.0	-	48.0	mV	T3
Battery voltage sensor input range	Vrng		1800	-	5000	mV	T3
Internal Temperature sensor input range	Trng		-20	-	85	°C	T3
THM pin internal resistance	Pthm		-	10.0	-	kΩ	T3
Regulator voltage	Vreg	VDD=3.6V @25°C	1.76	1.8	1.84	V	T4
Regulator voltage for thermistor	Treg	VDD=3.6V @25°C	1.76	1.8	1.84	V	T4
VBAT input impedance	Pcell	VBAT=3.6V	2.0	3.5	-	MΩ	T5
Reset detecting voltage	Vrst	design assurance	1.7	1.9	2.1	V	-
Reset hysteresis voltage	Vrhys	design assurance	0.10	0.15	0.20	V	-

*3 The test circuit symbols.

(2) I2C/IO interface characteristics : Characteristics of the SDA and SCL I/O stages.

PARAMETER	SYMBOL	CONDITIONS	MIN.	TYP.	MAX.	UNIT	*4
(SCL, SDA, IO1, IO4, IO5) Low level input voltage	VIL1		-0.3	-	0.6	V	T8
(CE) Low level input voltage	VIL2		-0.3	-	0.4	V	T8
(SCL, SDA, ALERT, IO1, IO4) High level input voltage	VIH1		1.2	-	VDD+0.3	V	T8
(IO5) High level input voltage	VIH2		1.2	-	5.5	V	T8
(CE) High level input voltage	VIH3		1.0	-	VDD+0.3	V	T8
(SCL, SDA, CE, Alert, IO1, IO4, IO5) Input voltage hysteresis	Vhys		0.1	-	-	V	T8
(SCL, SDA, ALERT, IO1, IO4, IO5) Low Level output voltage	Vol	Iol=3mA	-	-	0.4	V	T6
(IO1, IO4) output High level voltage	Voh	Ioh=1mA	VDD-0.5	-	-	V	T6
SCL,SDA Pulse width of spikes suppressed by input filter	tsp		50	-	-	ns	T8
Input current each I/O pin	Ii	input voltage between 0.1 and 0.9 VCCmax	-10	-	10	mA	T7
Capacitance for each I/O pin	Ci		-	-	10	pF	T8

*4 The test circuit symbols.

(3) I2C interface characteristics : Characteristics of the SDA and SCL bus lines

All values referred to VIHmin and VILmax levels (see Table (2)).

PARAMETER	SYMBOL	CONDITIONS	MIN.	TYP.	MAX.	UNIT	*5
SCL clock frequency	fSCL		0	-	400	kHz	T8
Hold time START condition	tHD:STA		0.6	-	-	ms	T8
Low period of SCL clock	tLOW		1.3	-	-	ms	T8
High period of SCL clock	tHIGH		0.6	-	-	ms	T8
Setup time for a repeated START condition	tSU:STA		0.6	-	-	ms	T8
Data hold time	tHD:DAT	for I2C-bus devices	0	-	- (*6)	ms	T8
Data set-up time	tSU:DAT		100 (*7)	-	-	ns	T8

*5 The test circuit symbols.

*6 The maximum tHD;DAT has only to be met if the device does not stretch the LOW period (tLOW) of the SCL signal.

*7 A Fast-mode I2C-bus device can be used in a Standard-mode I2C-bus system, but the requirement $t_{SU;DAT} \geq 250$ ns must then be met. This will automatically be the case if the device does not stretch the LOW period of the SCL signal. If such a device does stretch the LOW period of the SCL signal, it must output the next data bit to the SDA line $t_{r\ max} + t_{SU;DAT} = 1000 + 250 = 1250$ ns (according to the Standard-mode I2C-bus specification) before the SCL line is released.

PARAMETER	SYMBOL	CONDITIONS	MIN.	TYP.	MAX.	UNIT	*8
Fall time of SDA signals	tF	I _{OL} = 3mA	-	-	300	ns	T8
Setup time for STOP condition	tSU:STO		0.6	-	-	ms	T8
Bus free time between a STOP and START condition	tBUF		1.3	-	-	ms	T8
Capacitive load for each bus line	C _b		-	-	400	pF	T8

*8 The test circuit symbols.

FUNCTION

MM8118 measures current, voltage, and temperature periodically, and monitors the remaining capacity and condition of a lithium ion battery.

FUEL GAUGE

By periodical current measurement, this IC recognizes charge / discharge current flow and integrates charge / discharge current. And it also manages the battery capacity which remains (remaining capacity).

It is possible to get useful information which is operation time (usable time) on the basis of such managed capacity.

However, since this IC may accumulate few errors for a long time even if it integrates current measured by high accuracy $\Delta\Sigma$ ADC, it has a function which correct the remaining capacity from the measurement voltage in the state (OCV), when the specific conditions were satisfied.

Correction of remaining capacity by OCV

From the measured voltage at the state when the specific conditions were satisfied, and the characteristic data of the battery which were saved in the built-in memory, the correction of the remaining capacity by open voltage (OCV) is performed the calculation of the ideal remaining capacity, and is corrected the difference with the present remaining capacity.

The above-mentioned remaining capacity correction is performed when the following all conditions are satisfied.

- 1) The measurement current is less than a threshold value
- 2) The specific time passed which the return voltage is stable after charge and discharge
- 3) The measurement temperature is less than a threshold value
- 4) The threshold time passes after the remaining capacity was corrected

Battery Capacity

The battery capacity is defined as the maximum capacity of the battery usable range for this IC.

Battery capacity decreases gradually with prolonged use.

Then, when the specific conditions are satisfied, this IC performs the calculation of the battery capacity, and applies the calculation result to the present battery capacity.

- 1) Charge is performed more than a threshold capacity until more than the specified voltage
- 2) OCV measurement is performed before Charge start and after Charge end

Since the device calculates the ratio of change (capacity degradation rate) from initial battery capacity at updating, it is possible to refer it with the judgment of battery degradation.

Initial remaining capacity at Power On Reset

The initial remaining capacity which calculated after applied power to IC is calculated as following. The device assumes that the battery is in the relaxed state with no current flow for 30min just before applied power, and converts the first measured battery voltage to the remaining capacity. This conversion table called OCV table.

Chip enable pin

This device has a Chip enable pin. When Chip enable pin is low level, the device changes to Shutdown mode.

POWER MANAGEMENT

In this IC which manages the remaining capacity and monitors the condition of lithium ion battery, it is an important point to reduce the power consumption.

The operational mode diagram and each mode description are shown below.

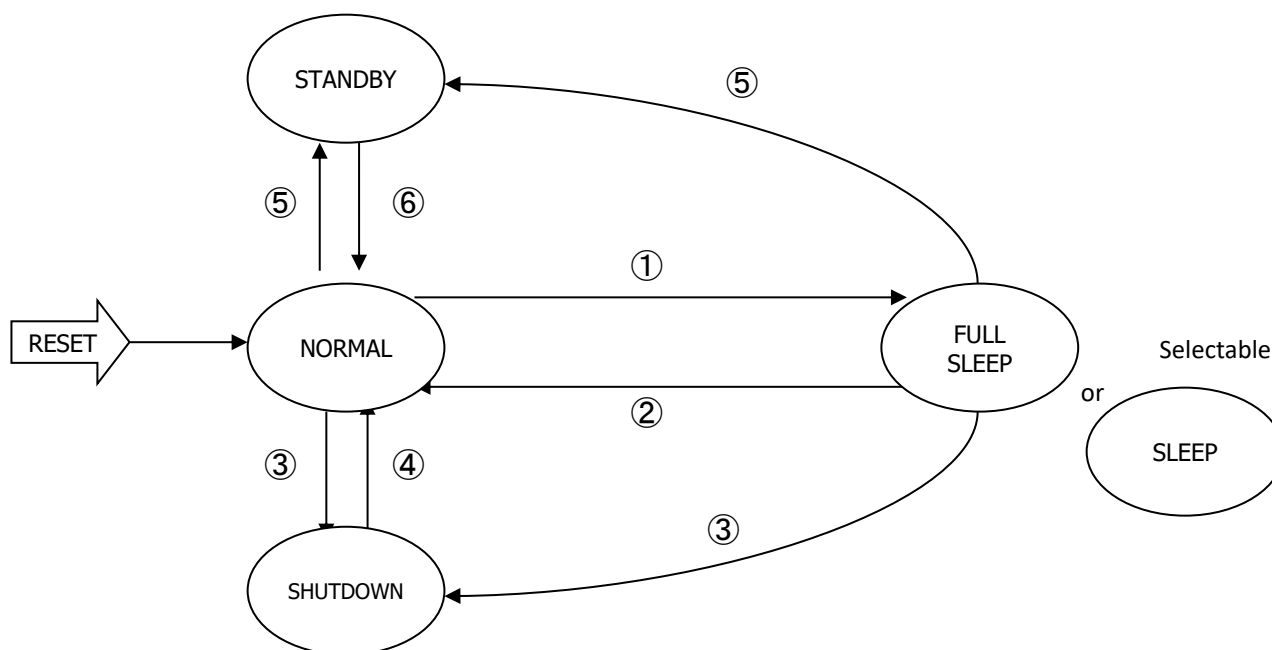

- ① The specific time is passed in state which the measured current is less than threshold value.
 Receiving the command to FULL SLEEP (or SLEEP) mode change.
- ② The measured current is more than threshold value.
 Receiving the command to NORMAL mode change.
- ③ Battery voltage is less than low limit voltage of IC when SHUTDOWN setting of Control Status is 1.
 Receiving the command to SHUTDOWN mode change.

Input low level to Chip enable pin

- ④ If Chip enable pin state is high level, input the command with selected slave address on I2C communication.
 If Chip enable pin state is low level, input high level to Chip enable pin.

- ⑤ Battery voltage is less than low limit voltage of IC when HIBERNATE setting of Control Status is 1.
 Receiving the command to STANDBY mode change.

- ⑥ Receiving I2C command.

NORMAL mode

Current, voltage, and temperature are measured, and the management of remaining capacity are performed.

Measurement / processing cycle is performed in a cycle of 1 second (Default).

I2C communication is always in valid state.

Mode Change condition

- Mode change command is received → Each requested mode
- The specific time is passed in state which the measured current is less than threshold value → FULL SLEEP mode (or SLEEP mode)
- The specific time is passed in state which the battery voltage is less than threshold value → STANDBY mode or SHUTDOWN mode

FULL SLEEP mode

Current, voltage, and temperature are measured, and the management of remaining capacity are performed.

Measurement / processing cycle is performed in a cycle of 60 seconds (Default). The IC is in ultra-low power mode during no measurement / no processing condition.

I2C communication is always in valid state.

Mode Change condition

- Mode change command is received → Each requested mode
- The measured current is more than threshold value → NORMAL mode
- The specific time is passed in state which the battery voltage is less than threshold value → STANDBY mode or SHUTDOWN mode

SLEEP mode

Current, voltage, and temperature are measured, and the management of remaining capacity are performed.

Measurement / processing cycle is performed in a cycle of 20 seconds (Default). The IC is in normal-low power mode during no measurement / no processing condition.

I2C communication is always in valid state.

Mode Change condition

- Mode change command is received → Each requested mode
- The measured current is more than threshold value → NORMAL mode
- The specific time is passed in state which the battery voltage is less than threshold value → STANDBY mode or SHUTDOWN mode

STANDBY mode

In STANDBY mode, fuel gauge processing stops. Volatile RAM contents are maintained.

And, all registers are maintained.

To exit from STANDBY mode, host send any I2C command.

Mode Change condition

- I2C command is received. → NORMAL mode

SHUTDOWN mode

In SHUTDOWN mode, all activity stops, and volatile RAM contents are lost.

All registers are lost.

When the IC exits from SHUTDOWN mode, power-on-reset occurs and then the IC enter NORMAL mode.

Mode Change condition

- If Chip enable pin state is high level,
Input the command with selected slave address
on I2C communication. → NORMAL Mode via POR
- If Chip enable pin state is low level,
Input high level to Chip enable pin. → NORMAL Mode via POR

ALERT Function

An alert interrupt can be output for a host, depending on a state of Flags (*9).

This alert interrupt is output by ALERT. (*9: see Flags command section)

The condition to produce an alert interrupt, the selection of output signal and the polarity setting can be set in Data Flash.

When an alert interrupt occurs, ALERT output is asserted. The factor of alert interrupt are known in Flags. The alert interrupt is negated when the alert factors are cleared.

I2C CORRESPONDENCE

I2C correspondence is used for data transfer between IC and MCU.
 Communicate data in reference to I2C specification.

TIMING CHART

Timing chart of I2C correspondence is depicted below.
 Please refer to "ELECTRICAL CHARACTERISTICS" for symbols described in schematic.

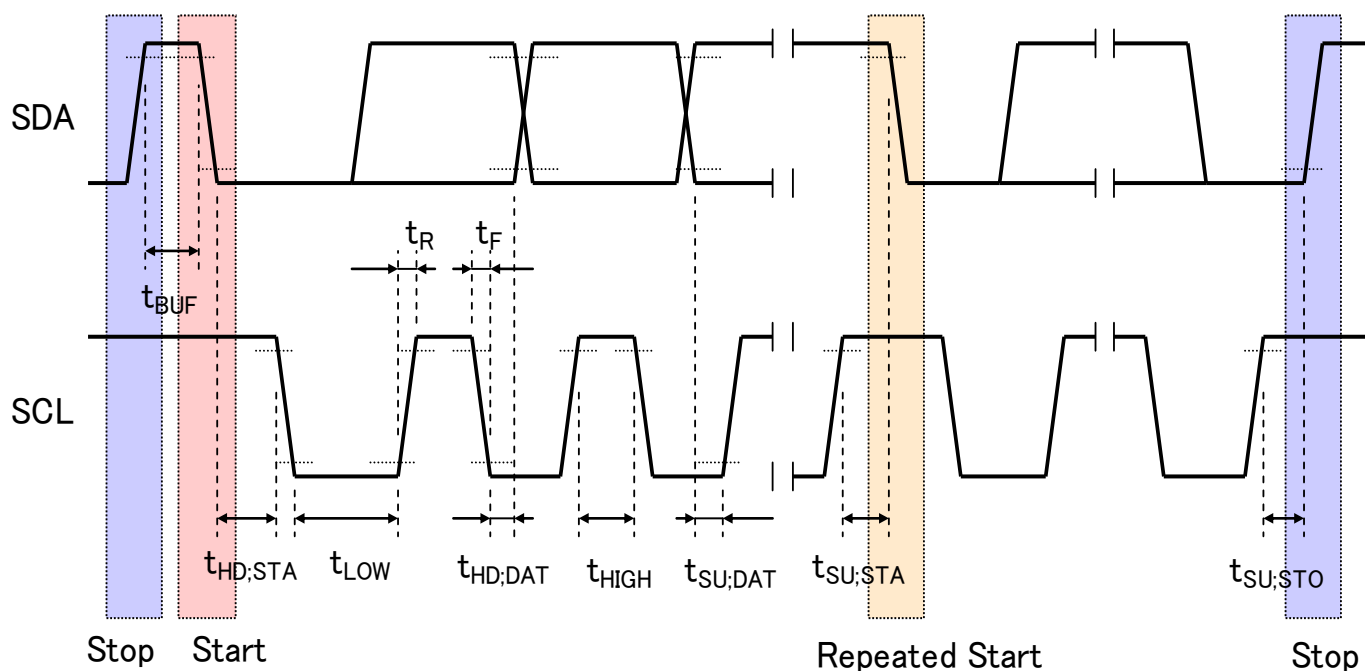

CORRESPONDENCE FORMAT

I2C write format (1 byte write : HOST → Device)

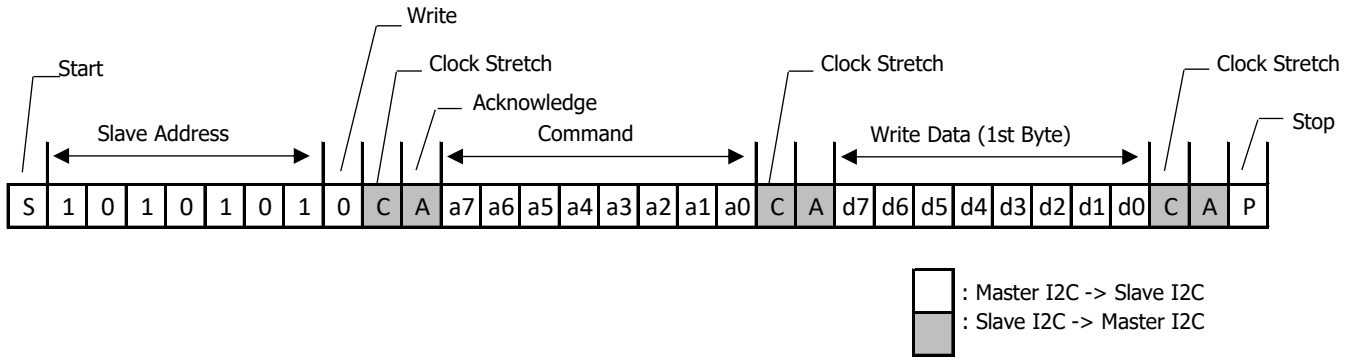

I2C write format (n byte incremental write : HOST → Device)

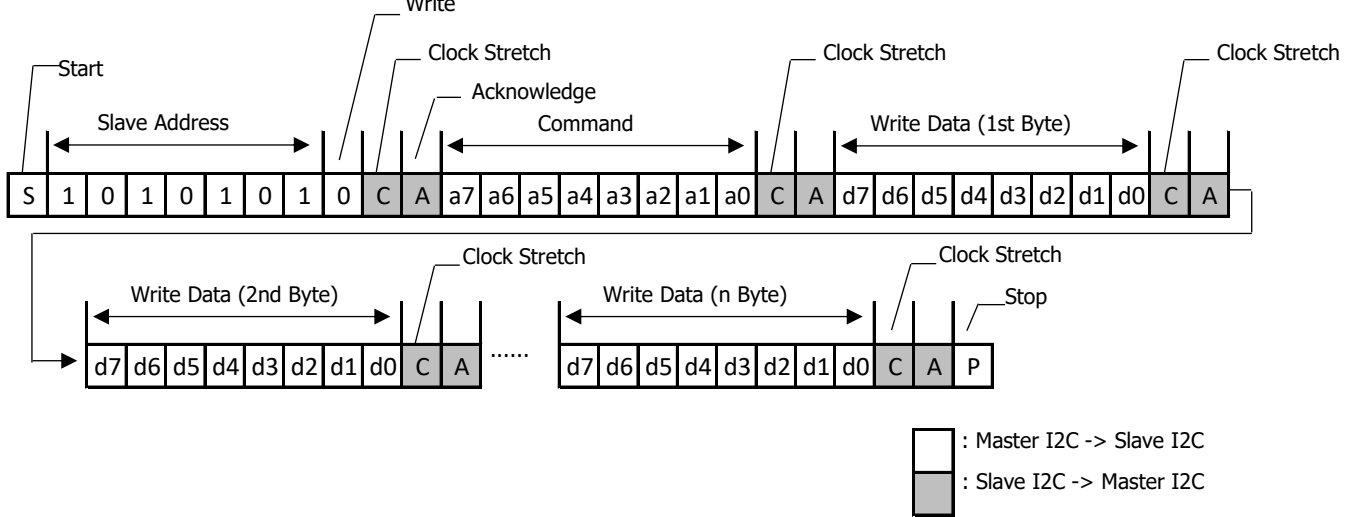

I2C read format (1 byte read : Device → Host)

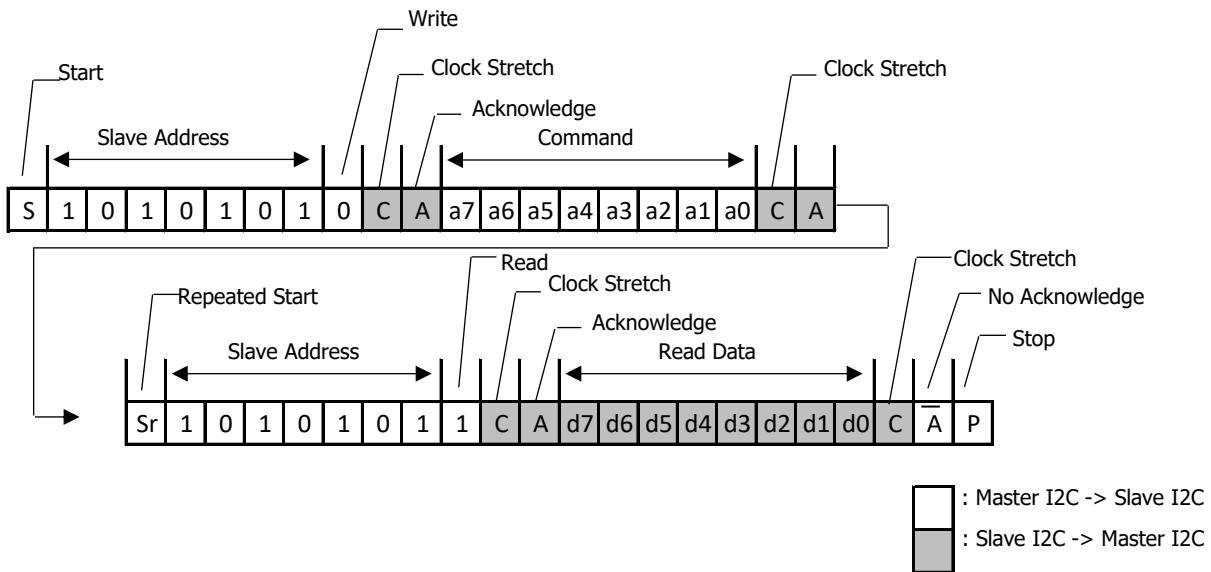

I2C quick read format (1 byte read : Device → Host)

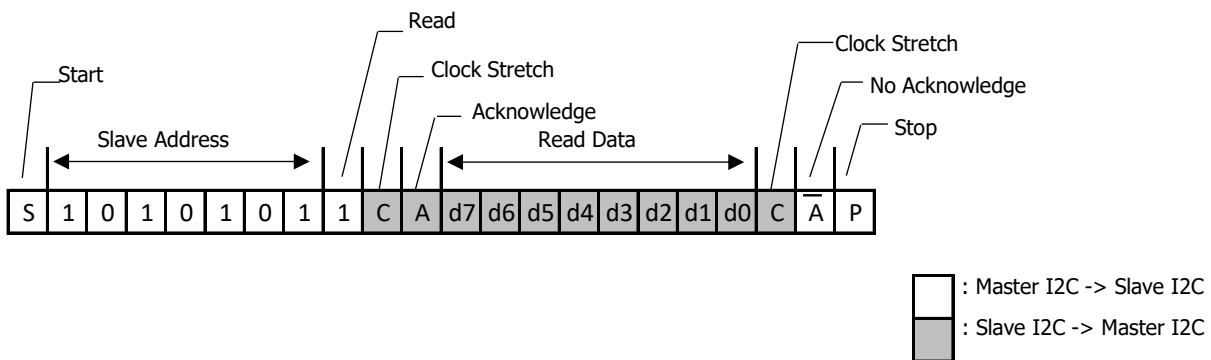

I2C read format (n byte incremental read : Device → Host)

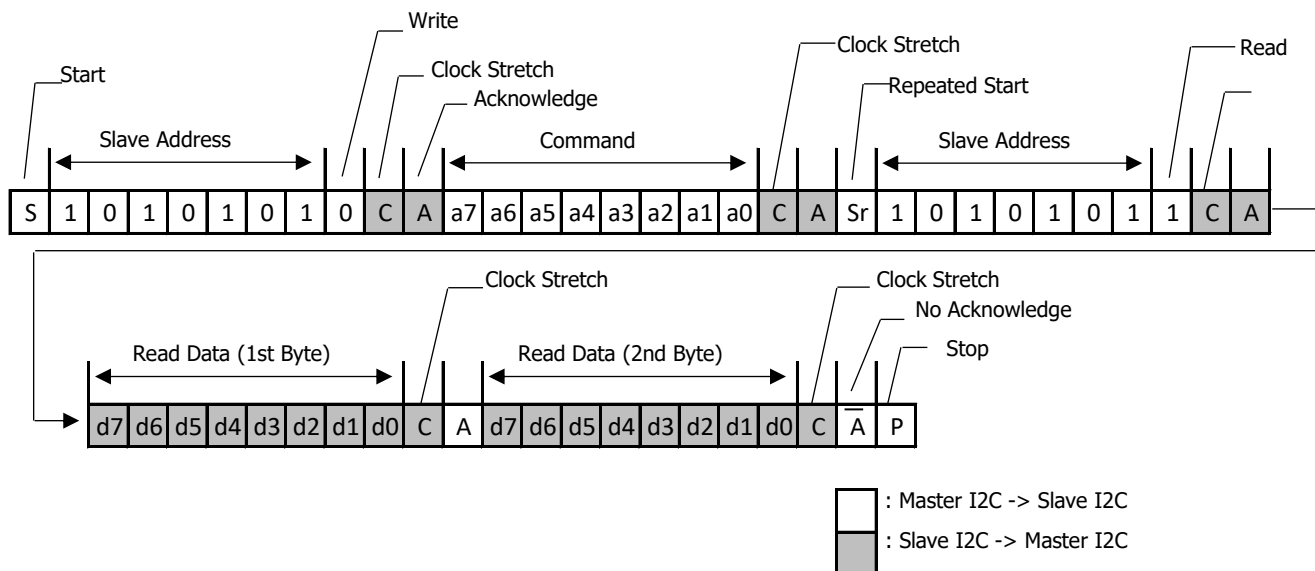

I2C DEVICE ADDRESS

The default of the device address is AA/AB.

The device address is recorded in internal NVM and is loaded at power-on. The I2C device address can be set to arbitrary value indicated by customer's request on our mass production line.

I2C TIMEOUT

MM8118 processes time-out in 0.2 second (Default) when it receives no reply from the host or I2C bus is continuously hold during I2C communication by the host. After time-out, the executing request is aborted and MM8118 will be ready condition of I2C protocol.

The settings of time-out value is stored in internal NVM and are modifiable.

I2C CLOCK STRETCH

MM8118 needs clock stretch for I2C communication with host device. Maximum period of clock stretch is 1ms.

I2C quick read format (1 byte read : Device → Host)

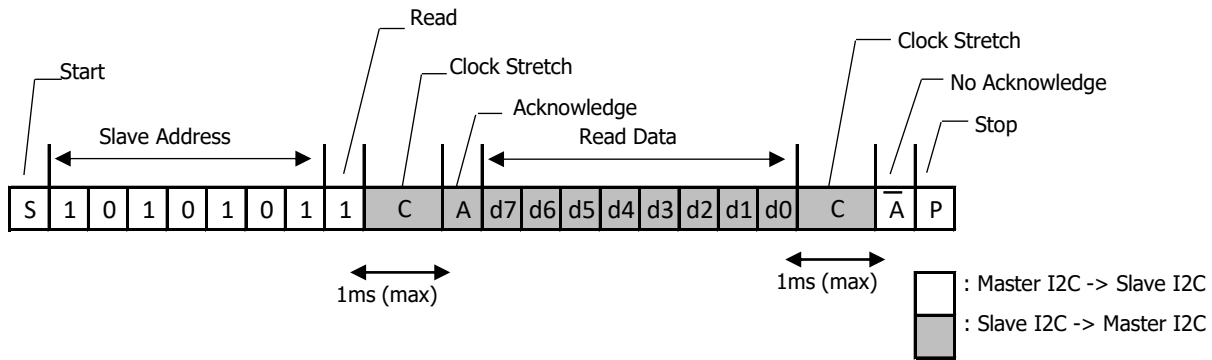

I2C WAIT TIME

MM8118 may require a wait time from the completion of I2C Write format to next start of I2C communication. (Bus free time between a STOP and START condition)

In case of the following command, the MM8118 needs the wait time for long.

Command List of Wait time

Code	Name	Wait time
0x00/0x01	Control (Reset request)	100msec
0x60	Block Data Checksum	
0x54	Authenticate Checksum	

I2C write format (n byte write : HOST → Device)

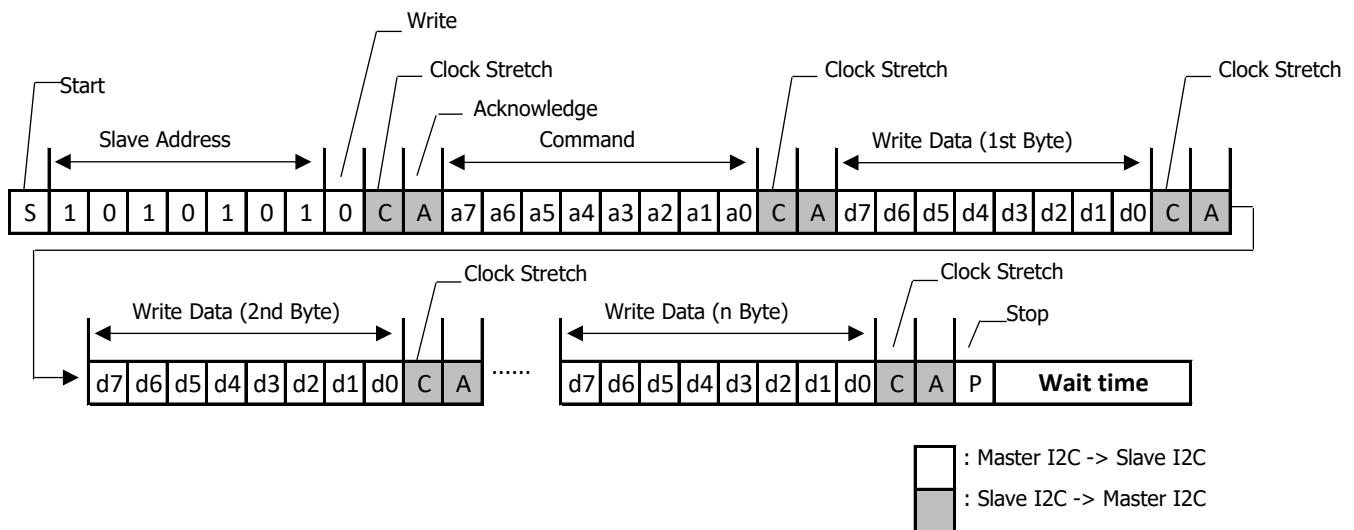

If the host sends I2C command without appropriate wait time, MM8118 will return Nack response.

COMMAND

COMMAND SUMMARY

This IC uses the command shown below to get various measurement information, and to setup operational mode.

Standard Command List

Name	Code	R/W	Data size	Unit
Control	0x00/0x01	R/W	2	N/A
At Rate	0x02/0x03	R/W	2	mA (or 0.1mA)
Unfiltered SOC	0x04/0x05	R	2	%
Temperature	0x06/0x07	R	2	0.1K (or 0.1°C)
Voltage	0x08/0x09	R	2	mV
Flags	0x0A/0x0B	R	2	N/A
Nominal Available Capacity	0x0C/0x0D	R	2	mAh (or 0.1mAh)
Full Available Capacity	0x0E/0x0F	R	2	mAh (or 0.1mAh)
Remaining Capacity	0x10/0x11	R	2	mAh (or 0.1mAh)
Full Charge Capacity	0x12/0x13	R	2	mAh (or 0.1mAh)
Average Current	0x14/0x15	R	2	mA (or 0.1mA)
Average Time To Empty	0x16/0x17	R	2	minutes
Filtered FCC	0x18/0x19	R	2	mAh (or 0.1mAh)
Reserved	0x1A/0x1B	-	-	-
Unfiltered FCC	0x1C/0x1D	R	2	mAh (or 0.1mAh)
Max Load Current	0x1E/0x1F	R	2	mA (or 0.1mA)
Unfiltered RM	0x20/0x21	R	2	mAh (or 0.1mAh)
Filtered RM	0x22/0x23	R	2	mAh (or 0.1mAh)
BTP SOC1 Set	0x24/0x25	R/W	2	mAh (or 0.1mAh)
BTP SOC1 Clear	0x26/0x27	R/W	2	mAh (or 0.1mAh)
Internal Temperature	0x28/0x29	R	2	0.1K (or 0.1°C)
Cycle Count	0x2A/0x2B	R	2	Counts
State Of Charge	0x2C/0x2D	R	2	%
State Of Health	0x2E/0x2F	R	2	%
Charge Voltage	0x30/0x31	R	2	mV
Charge Current	0x32/0x33	R	2	mA (or 0.1mA)
Passed Charge	0x34/0x35	R	2	mAh (or 0.1mAh)
DOD0	0x36/0x37	R	2	N/A
Self Discharge Current	0x38/0x39	R	2	mA (or 0.1mA)

Extended Command List

Name	Code	R/W	Data size	Unit
Pack Config	0x3A/0x3B	R	2	N/A
Design Capacity	0x3C/0x3D	R	2	mAh (or 0.1mAh)
Data Flash Class	0x3E	R/W	1	N/A
Data Flash Block	0x3F	R/W	1	N/A
Block Data / Authenticate	0x40~0x53	R/W	20	N/A
Block Data / Authenticate Checksum	0x54	R/W	1	N/A
Block Data	0x55~0x5F	R/W	11	N/A
Block Data Checksum	0x60	R/W	1	N/A
Block Data Control	0x61	R/W	1	N/A
Product Information Length	0x62	R	1	N/A
Product Information	0x63~0x6C	R	10	N/A
FG Condition	0x6E/0x6F	R/W	2	N/A
Reserved	0x70/0x71	-	-	-
Current	0x72/0x73	R	2	mA (or 0.1mA)
Reserved	0x74~0x7F	-	-	-

STANDARD COMMAND DETAIL (Group1)

The commands which response data size is 2 bytes are shown below.

Unfiltered SOC [0x04/0x05]

This command returns the percentage of usable unfiltered capacity to usable unfiltered full charge capacity based on temperature and discharge current. If no current flows or charge current flows, it returns the percentage which based on defined discharge (about 0.2C).

Data Type : unsigned integer
Unit : [%]

Temperature [0x06/0x07]

This command returns the temperature information measured from the external thermistor input or measured by the temperature sensor built in this IC.

Data Type : signed integer
Unit : [0.1K] ([0.1°C] selectable by Data Flash setting)

Voltage [0x08/0x09]

This command returns the voltage of a battery or a battery pack.

Data Type : unsigned integer
Unit : [mV]

Nominal Available Capacity [0x0C/0x0D]

This command returns the remaining capacity of a battery.
The absolute remaining capacity is a capacity under standard conditions (0.2C discharge, 25°C).

Data Type : unsigned integer
Unit : [mAh] ([0.1mAh] selectable by Data Flash setting)

Full Available Capacity [0x0E/0x0F]

This command returns the full charge capacity.
The full charge capacity is a full capacity under standard conditions (0.2C discharge, 25°C).

Data Type : unsigned integer
Unit : [mAh] ([0.1mAh] selectable by Data Flash setting)

Remaining Capacity [0x10/0x11]

This command returns the usable capacity based on temperature and discharge current.

smoothing valid setting : Filtered RM value
smoothing invalid setting : Unfiltered RM value

Data Type : unsigned integer
Unit : [mAh] ([0.1mAh] selectable by Data Flash setting)

Full Charge Capacity [0x12/0x13]

This command returns the full charge capacity based on temperature and discharge current.

smoothing valid setting : Filtered FCC value
smoothing invalid setting : Unfiltered FCC value

Data Type : unsigned integer
Unit : [mAh] ([0.1mAh] selectable by Data Flash setting)

Average Current [0x14/0x15]

This command returns the average current which flows into a battery or out from a battery.

Data Type : signed integer
Unit : [mA] ([0.1mA] selectable by Data Flash setting)

Average Time To Empty [0x16/0x17]

This command returns operation time (usable time) from average current and temperature.

If no current flows, the value calculated as default discharge is returned, and if charge current flows, a value of 65535 is returned.

Data Type : unsigned integer
Unit : [minutes]

Filtered FCC [0x18/0x19]

This command returns the usable filtered full charge capacity based on temperature and discharge current.

Data Type : unsigned integer
Unit : [mAh] ([0.1mAh] selectable by Data Flash setting)

Unfiltered FCC [0x1C/0x1D]

This command returns the usable unfiltered full charge capacity based on temperature and discharge current.

Data Type : unsigned integer
Unit : [mAh] ([0.1mAh] selectable by Data Flash setting)

Max Load Current [0x1E/0x1F]

This command returns the maximum current which flows out from a battery.
Max load current is updated to the measured current which is greater than the stored value or initial max load setting. And it is reseted to the average of the latest value and initial value at full charge condition.

Data Type : signed integer
Unit : [mA] ([0.1mA] selectable by Data Flash setting)

Unfiltered RM [0x20/0x21]

This command returns the usable unfiltered capacity based on temperature and discharge current. If no current flow or charge current flow, the capacity which based on defined discharge current (about 0.2C).

Data Type : unsigned integer
Unit : [mAh] ([0.1mAh] selectable by Data Flash setting)

Filtered RM [0x22/0x23]

This command returns the usable filtered capacity based on temperature and discharge current. If no current flow or charge current flow, the capacity which based on defined discharge current (about 0.2C).

Data Type : unsigned integer
Unit : [mAh] ([0.1mAh] selectable by Data Flash setting)

Internal Temperature [0x28/0x29]

This command returns the temperature information measured by the temperature sensor built in this IC.

Data Type : signed integer
Unit : [0.1K] ([0.1°C] selectable by Data Flash setting)

Cycle Count [0x2A/0x2B]

This command returns the number full charge count to the present.

When total charged capacity reaches full charge capacity, the number of full charge count will be counted up 1.

Data Type : unsigned integer

Unit : [counts]

State Of Charge [0x2C/0x2D]

This command returns the percentage of usable capacity to usable full charge capacity based on temperature and discharge current. If no current flows or charge current flows, it returns the percentage which based on defined discharge current (about 0.2C).

Data Type : unsigned integer

Unit : [%]

State Of Health [0x2E/0x2F]

This command returns the percentage of the present battery capacity to the initial battery capacity.

Data Type : unsigned integer

Unit : [%]

Passed Charge [0x34/0x35]

This command returns the amount of charge capacity from OCV after discharged.

Data Type : unsigned integer

Unit : [mAh] ([0.1mAh] selectable by Data Flash setting)

DOD0 [0x36/0x37]

This command returns the depth of discharge at last OCV.

Data Type : unsigned integer

Unit : N/A

Self Discharge Current [0x38/0x39]

This command returns the self-discharge current of battery.

Data Type : signed integer

Unit : [mAh] ([0.1mAh] selectable by Data Flash setting)

Flags [0x0A/0x0B]

This command returns the battery status/information.

The battery status/information are assigned to each bit as follows.

Battery status bit

	bit7	bit6	bit5	bit4	bit3	bit2	bit1	bit0
Hi byte	OTC	OTD	BATHI	BATLOW	CHG_INH	RSVD	FC	CHG
Lo byte	OCVTAKEN	OCC	ODC	OT	UT	SOC1	SOCF	DSG

OTC : Over Temperature in charge
When the current is more than or equal to charge threshold current,
More than or equal to upper temperature limit : 1
Less than or equal to recover temperature : 0

OTD : Over Temperature in discharge
When the current is less than or equal to discharge threshold current,
More than or equal to upper temperature limit : 1
Less than or equal to recover temperature : 0

BATHI : Over-Charge
More than or equal to upper voltage limit : 1
Less than or equal to recover voltage : 0

BATLOW : Over-Discharge
Less than or equal to lower voltage limit : 1
More than or equal to recover voltage : 0

CHG_INH : Charge Inhibit
When the current is more than or equal to charge threshold current,
charge inhibit temperature (upper/lower limit) : 1
charge permission temperature or the current is less than charge threshold current : 0

FC : Full Charge
Full charge detection : 1
SOC < Full charge release threshold SOC : 0

Full charge detection condition

- 1) Voltage is more than or equal to full-charge voltage.
- 2) Current is less than charge termination current.
- 3) The condition of 1) and 2) are detected for the setting time

CHG : charge allowed
SOC is less than or equal to charge allowed SOC,
and CHG_INH = 0 : 1
SOC is more than full charge release threshold SOC
or CHG_INH = 1 : 0

OCVTAKEN	Correct Remaining Capacity	Corrected the remaining capacity by OCV: 1 not Corrected the remaining capacity by OCV: 0
OCC	: Over Charge Current	More than or equal to upper current limit : 1 Less than or equal to recover current : 0
ODC	: Over Discharge Current	Less than or equal to lower current limit : 1 More than or equal to recover current : 0
OT	: Over Temperature	More than or equal to upper temperature limit : 1 Less than or equal to recover temperature : 0
UT	: Under Temperature	Less than or equal to lower temperature limit : 1 More than or equal to recover temperature : 0
SOC1	: It shows following status by the selection of function.	

<Remaining Capacity Notification Function = Valid>

SOC1 detection (Discharging)	Remaining Capacity < SOC1 Set Threshold : 1 Remaining Capacity > SOC1 Clear Threshold : 1→0 or 0→1
SOC1 detection (Charging)	Remaining Capacity < SOC1 Set Threshold : 1 Remaining Capacity > SOC1 Clear Threshold : 1→0 or 0→1 *Set/Clear SOC1command is received : 0

<Remaining Capacity Notification Function = Invalid>

SOC1 detection	Remaining Capacity \leq SOC1 Set Threshold : 1 Remaining Capacity \geq SOC1 Clear Threshold : 0
SOCF : SOC Final detection	Remaining Capacity \leq SOCF Set Threshold : 1 Remaining Capacity \geq SOCF Clear Threshold : 0
DSG : Discharge	Discharge : 1, Charge or 0mA : 0

STANDARD COMMAND DETAIL (Group 2)

The command which transmits and receives parameter data to this IC is shown below.

Control [0x00/0x01]

This command returns various setting data / information of this IC, and sets various control setting. The above process is performed by the parameter which is sent 2bytes data with command.

Command Parameter

Control Command Parameter

	Name
Byte 0	Request Code Low Byte
Byte 1	Request Code Hi Byte

Receive Data

Control Data Format

	Name
Byte 0	Data Low Byte
Byte 1	Data Hi Byte

[Request code list]

Request code table

Request content code	Code	type	Description
CONTROL_STATUS	0x0000	R	status information
DEVICE_TYPE	0x0001	R	device type
FW_VERSION	0x0002	R	firmware version
HW_VERSION	0x0003	R	hardware version
RANK_CODE	0x0004	R	rank code information
PREV_MACWRITE	0x0007	R	previous MAC
CHEM_ID	0x0008	R	data flash ID (parameter ID)
DF_VERSION	0x000C	R	data flash revision (parameter rev.)
SET_SLEEP	0x0010	W	enable to change FULL SLEEP mode
SET_HIBERNATE	0x0011	W	enable to change HIBERNATE mode
CLEAR_HIBERNATE	0x0012	W	disable to change HIBERNATE mode
SET_SHUTDOWN	0x0013	W	enable to change SHUTDOWN mode
CLEAR_SHUTDOWN	0x0014	W	disable to change SHUTDOWN mode
OCV_CMD	0x001F	W	execute OCV correction
SEALED	0x0020	W	set SEALED access mode
IG_ENABLE	0x0021	W	enable device to normal FG operation mode
CAL_ENABLE	0x002D	W	set device to Calibration test mode
SET_LOCKTYPE	0x0040	W	set device Lock type
RESET	0x0041	W	reset device
EXIT_CAL	0x0080	W	stop device to measure Calibration
ENTER_CAL	0x0081	W	start device to measure Calibration

CONTROL_STATUS [0x0000]

This request code returns the various status information of the device.

	bit7	bit6	bit5	bit4	bit3	bit2	bit1	bit0
Hi byte	RSVD	FAS	SS	CALMODE	RSVD	RSVD	QMAXUPDATE	RSVD
Lo byte	SHUTDOWN	HIBERNATE	FULLSLEEP	SLEEP	LDMD	DNR	VOK	QEN

FAS	: FULL ACCESS SEALED state	If device is Full Access Sealed (The specific area of Data Flash is read/write prevented) condition, it is set to 1.
SS	: SEALED / UNSEALED state	If device is Sealed (Data Flash is read/write prevented) condition, it is set to 1.
CALMODE	: Calibration function	If Calibration function is enabled (after CAL_ENABLE is sent), it is set to 1.
QMAXUPDATE	: QMAX update	It shows battery capacity update. It toggled by each update.
SHUTDOWN	: SHUTDOWN function	If device is enabled to change SHUTDOWN mode, it is set to 1.
HIBERNATE	: HIBERNATE function	If device is enabled to change STANDBY mode, it is set to 1.
FULLSLEEP	: FULL SLEEP function	If device is enabled to change FULL SLEEP mode, it is set to 1.
SLEEP	: SLEEP function	It shows the device is in FULL SLEEP mode (or SLEEP mode).
LDMD	: Constant power/ Constant current algorithm	Constant power mode : 1
DNR	: Device not Ready	When FG operation mode is started, it is set to 1 until FG information is ready. In the following cases, the device starts from DNR = 1 condition. 1) after POR, 2) after change to Normal mode from Standby mode.
VOK	: Voltage OK	When device is judged voltage stable, it is set to 1.
QEN	: FG mode enable	When device is normal FG operation mode, it is set to 1. (after IG_ENABLE is sent)

DEVICE_TYPE [0x0001]

This request code returns the type information of this IC. This IC returns "0x8118".

FW_VERSION [0x0002]

This request code returns the firmware version.

HW_VERSION [0x0003]

This request code returns the hardware version. This IC returns "0x001C".

RANK_CODE [0x0004]

This request code returns the model rank code information. This IC returns "0x3257" (= 'W2').

PREV_MACWRITE [0x0007]

This request code returns the previous value of Control command.

CHEM_ID [0x0008]

This request code returns ID information of battery parameter which is set in Data Flash.

DF_VERSION [0x000C]

This request code returns the battery parameter version which is set in Data Flash.

SET_SLEEP [0x0010]

This request code enables to change the device power mode to FULL SLEEP mode.

SET_HIBERNATE [0x0011]

This request code enables to change the device power mode to HIBERNATE mode.

CLEAR_HIBERNATE [0x0012]

This request code disables to change the device power mode to HIBERNATE mode.

SET_SHUTDOWN [0x0013]

This request code enables to change the device power mode to SHUTDOWN mode.

CLEAR_HIBERNATE [0x0014]

This request code disables to change the device power mode to SHUTDOWN mode.

OCV_CMD [0x001F]

This request code executes OCV correction by the measured voltage.

SEALED [0x0020]

This request code sets SEALED access mode to the device.

IG_ENABLE [0x0021]

This request code enables Intelligent Gauge algorithm. And this request is only valid when the device is in UNSEALED state.

CAL_ENABLE [0x002D]

This request code sets Calibration operation mode if this IC is in normal FG operation mode, and it sets normal FG operation mode if this IC is in Calibration operation mode. And this request is only valid when it is in UNSEALED state.

SET_LOCKTYPE [0x0040]

This request code returns Lock type value of this IC.

RESET [0x0041]

This request code resets this IC. And this request is only valid when it is in UNSEALED state.

EXIT_CAL [0x0080]

This request code stops the calibration process in case of Calibration operation mode. And this request is only valid when this IC is in UNSEALED state.

ENTER_CAL [0x0081]

This request code starts the calibration process in case of Calibration operation mode. And this request is only valid when this IC is in UNSEALED state.

At Rate [0x02/0x03]

This command sets current value to calculate the operation time (usable time) at the present temperature. The calculated operation time by specified this command is available on 'At Rate Time To Empty [0x04/0x05]' command.

Command Parameter

Data Type : signed integer
Unit : [mA] ([0.1mA] selectable by Data Flash setting)

Receive Data

Data Type : signed integer
Unit : [mA] ([0.1mA] selectable by Data Flash setting)

BTP SOC1 Set [0x24/0x25]

This command sets the discharge threshold of remaining capacity, which is parameter of Remaining Capacity Notification Function.

If Remaining Capacity Notification Function is enabled, the interrupt is generated when the remaining capacity is below this discharge threshold.

And the interrupt signal and status flag are cleared to set this command.

Command Parameter / Receive Data

Data Type : unsigned integer
Unit : [mAh] ([0.1mAh] selectable by Data Flash setting)

BTP SOC1 Clear [0x26/0x27]

This command sets the charge threshold of remaining capacity, which is parameter of Remaining Capacity Notification Function.

If Remaining Capacity Notification Function is enabled, the interrupt is generated when the remaining capacity is above this charge threshold.

And the interrupt signal and status flag are cleared to set this command.

Command Parameter / Receive Data

Data Type : unsigned integer
Unit : [mAh] ([0.1mAh] selectable by Data Flash setting)

EXTENDED COMMAND DETAIL (Group 3)

The command which response data size is multiple bytes is shown below.

Pack Config [0x3A/0x3B]

This command returns this IC setting information of selectable function.

Those selectable settings are assigned to each bit as follows.

	bit7	bit6	bit5	bit4	bit3	bit2	bit1	bit0
Hi byte	RSVD	INTPol	INTSel	RSVD	RSVD	RSVD	RSVD	CRESO
Lo byte	RSVD	RSVD	SLEEP	RSVD	RSVD	RSVD	RSVD	TEMPS

INTPol : Polarity for Interrupt pin Low Active : 0, High Active : 1

INTSel : Interrupt pin select SE pin : 0, HDQ pin : 1

CRESO : Unit select of Current and Capacity 1mA, 1mAh: 0, 0.1mA, 0.1mAh: 1

SLEEP : SLEEP function Sleep function enable : 1
Sleep function disable : 0

TEMPS : Thermistor measurement Thermistor enable : 1, Thermistor disable : 0

Design Capacity [0x3C/0x3D]

This command returns the design capacity of a battery.

Data Type : unsigned integer

Unit : [mAh]

Product Information Length [0x62]

This command returns the length of the product information data.

Data Type : unsigned char

Unit : N/A

Product Information [0x63~0x6C]

This command returns the product information.

The information data is 10bytes in binary data.

Name	Size
Device Model Name	8bytes
Reserved	2bytes

Current [0x72/0x73]

This command returns the measured current which flows into a battery or out from a battery.

Data Type : signed integer
Unit : [mA] ([0.1mA] selectable by Data Flash setting)

EXTENDED COMMAND DETAIL (Group 4)

The command which transmits and receives parameter data to this IC is shown below.

Data Flash Class [0x3E]

This command sets the data flash class which reads/writes some initial setting data and the parameter data of battery dependent from/to Data Flash. In case of SEALED state, the access is rejected.

Data Flash Block [0x3F]

This command sets the data flash block which reads/writes some initial setting data and the parameter data of battery dependent from/to Data Flash.

In case of UNSEALED state, this IC is set 0x00 only, not set except for 0x00.

In SEALED state, the setting for the specific purpose is permitted only.

0x00 : set authenticate data
0x01 - 0x03 : get data of Manufacture Data A - C

Block Data [0x40~0x5F]

These 32bytes memory area is used for several purpose by SEALED/UNSEALED state and Data Flash Class [0x3E], Data Flash Block [0x3F], Block Data Control [0x61] commands setting.

other : The device is set Authenticate mode.

<In case of authentication usage>

This area is assigned to following definition.

Authenticate [0x40~0x53]

This area is used for authentication data.

Authenticate Checksum [0x54]

This command sets Checksum of 20bytes authentication data. The authenticate is performed by write operation.

Reserved [0x55~0x5F]

This area is not used.

Block Data Checksum [0x60]

This command sets/returns Checksum of 32bytes Block Data. In case of Read operation, it is updated at setting Class/Block value. In case of Write operation, it executes to save to Data Flash by updating latest Checksum result. In case of SEALED state, the access is rejected.

Block Data Control [0x61]

This command sets Data Flash mode. In case of SEALED state, the access is rejected.

0x00 : The device is set Data Flash Access mode which set/get some initial setting data and the parameter data of battery dependent by the specified data flash class/block.

other : The device is set Authenticate mode.

FG Condition [0x6E/0x6F]

This command returns the data of the operational mode, and sets the operational mode and executes the correction process.

Command Parameter

FG Condition Command Parameter	
	Name
Byte 0	Request code
Byte 1	Parameter

Receive Data

FG Condition Data Format	
	Name
Byte 0	Operational mode
Byte 1	reserved

[Request code]

<Execute code>

- 0x00 : NORMAL mode
- 0x01 : SLEEP mode
- 0x02 : SHUTDOWN mode
- 0x03 : STANDBY mode
- 0x04 : FULL SLEEP mode
- 0x20 : OCV correction (by measured Voltage)
- 0x21 : OCV correction (by Average Voltage)
- 0x40 : Lock Level (with parameter byte)
- 0x80 : System Reset request (It is valid in UNSEALED state only.)

[Operational mode]

- 0x00 : NORMAL mode
- 0x01 : SLEEP mode
- 0x02 or 0x03 : FULL SLEEP mode
- 0x04 : STANDBY mode

DATA FLASH

DATA FLASH SUMMARY

summarizes the data flash locations available to the user, including their default, minimum, and maximum values.

In case of SEALED state, Manufacture A/B/C area is available to read only.

The other Category area except for Security is available to read/write in UNSEALED state.

Security area is available to read/write at FULL ACCESS state only.

Data Flash List

Group	Category	Class	Offset	Name	Data Type	Min value	Max Value	Default Value	Unit		
Configuration	Data	0x00	0x00~01	Rank Code	Cbyte	-	-	"W2"	-		
			0x02	FW Version	Hword	0x0	0xffff	0x0100	-		
			0x04	Parameter Version	Hword	0x0	0xffff	0x0100	-		
			0x06	Mask FW Parameter Version	Hword	0x0	0xffff	0x0100	-		
			0x08~0f	Pack Name	Cbyte	-	-	-	-		
			0x10	Pack ID	Hword	0x0	0xffff	0x0	-		
	System	0x01	0x12	Pack sub ID	Hword	0x0	0xffff	0x0	-		
			0x08	PackConfigA	Hword	0x0	0xffff	0x0	-		
			0x0a	PackConfigB	Hbyte	0x0	0xff	0x0	-		
			0x0b	PackConfigC	Hbyte	0x0	0xff	0x0	-		
			0x0c	PackConfigD	Hbyte	0x0	0xff	0x0	-		
			0x0d	PackConfigE	Hbyte	0x0	0xff	0x0	-		
			0x0e	PackConfigF	Hbyte	0x0	0xff	0x0	-		
			0x0f	PackConfigG	Hbyte	0x0	0xff	0x0	-		
			0x10	Design Voltage	Uword	0	65535	3700	mV		
			0x12	Design Capacity	Uword	0	65535	2420	mAh		
			0x14	MaxLoad Default	Sword	-32768	32767	-500	mA		
			0x16	CycleCount Default	Uword	0	65535	0	num		
			Charge Term	0x02	0x10	Fullcharge Detect Voltage	Uword	0	65535	4350	mV
					0x12	Fullcharge Detect Voltage Window	Uword	0	65535	50	mV
	0x14	Fullcharge Detect Current			Uword	0	65535	100	mA		
	0x16	Fullcharge Detect Time			Ubyte	0	255	60	sec		
	0x17	Fullcharge Detect Current Window			Ubyte	0	255	10	mA		
	Discharge Term	0x02	0x18	Lower limit voltage	Uword	0	65535	3400	mV		
			0x1a	Force SOC 0% Voltage	Uword	0	65535	2750	mV		
	Current	0x03	0x11	Sleep detection time	Ubyte	0	255	60	sec		
			0x12	Sleep mode Interval	Ubyte	0	255	20	sec		
	Capacity	0x04	0x00	Initial capacity	Uword	0	65535	2450	mAh		
	Safety	0x05	0x00	SOC1 set threshold	Uword	0	65535	245	mAh		
			0x02	SOC1 clear threshold	Uword	0	65535	367	mAh		
			0x04	SOCF set threshold	Uword	0	65535	74	mAh		
			0x06	SOCF clear threshold	Uword	0	65535	184	mAh		
			0x08	Full charge flag clear threshold	Ubyte	0	255	98	%		
			0x09	CHG flag set threshold	Ubyte	0	255	95	%		
			0x0a	Charge Inhibit Low Limit Temperature	Sword	-32768	32767	-50	0.1°C		
			0x0c	Charge Inhibit Hi Limit Temperature	Sword	-32768	32767	500	0.1°C		
			0x0e	Charge Inhibit Hysteresis	Sbyte	-128	127	50	0.1°C		
			0x10	Alert IO Enable	Hword	0x0	0xffff	0x0	-		
			0x12	Battery Low-voltage detection	Uword	0	65535	2950	mV		
			0x14	Battery Low-voltage recovery	Uword	0	65535	3100	mV		
			0x16	Battery Low-voltage delay time	Ubyte	0	255	2	sec		
			0x17	Battery Hi-voltage delay time	Ubyte	0	255	2	sec		
			0x18	Battery Hi-voltage detection	Uword	0	65535	4400	mV		
			0x1a	Battery Hi-voltage recovery	Uword	0	65535	4300	mV		
			0x1c	Discharge current	Sword	-32768	32767	-10	mA		
0x1e			Charge current	Sword	-32768	32767	10	mA			

Data Flash List

Group	Category	Class	Offset	Name	Data Type	Min value	Max Value	Default Value	Unit	
Configuration	Safety	0x06	0x00	Hi-temperature in discharge detection	Sword	-32768	32767	600	0.1°C	
			0x02	Hi-temperature in discharge recovery	Sword	-32768	32767	550	0.1°C	
			0x04	Hi-temperature in discharge delay time	Ubyte	0	255	2	sec	
			0x05	Hi-temperature in charge delay time	Ubyte	0	255	2	sec	
			0x06	Hi-temperature in charge detection	Sword	-32768	32767	550	0.1°C	
			0x08	Hi-temperature in charge recovery	Sword	-32768	32767	500	0.1°C	
			0x0a	Over-discharge current detection	Sword	-32768	32767	-3000	mA	
			0x0c	Over-discharge current recovery	Sword	-32768	32767	-2000	mA	
			0x0e	Over-discharge current delay time	Ubyte	0	255	2	sec	
			0x0f	Over-charge current delay time	Ubyte	0	255	2	sec	
			0x10	Over-charge current detection	Sword	-32768	32767	3000	mA	
			0x12	Over-charge current recovery	Sword	-32768	32767	2000	mA	
			0x14	Under-temperature detection	Sword	-32768	32767	-200	0.1°C	
			0x16	Under-temperature recovery	Sword	-32768	32767	-150	0.1°C	
			0x18	Under-temperature delay time	Ubyte	0	255	2	sec	
			0x19	Over-temperature delay time	Ubyte	0	255	2	sec	
			0x1a	Over-temperature detection	Sword	-32768	32767	600	0.1°C	
			0x1c	Over-temperature recovery	Sword	-32768	32767	550	0.1°C	
		0x07	0x00	System shutdown voltage detection	Uword	0	65535	2400	mV	
			0x02	System shutdown voltage recovery	Uword	0	65535	2500	mV	
			0x04	System shutdown voltage delay time	Ubyte	0	255	8	sec	
			0x05	SOH TDD threshold	Ubyte	0	255	75	%	
			0x06	Under-voltage detection	Uword	0	65535	2850	mV	
			0x08	Under-voltage recovery	Uword	0	65535	3000	mV	
0x0a	Under-voltage delay time		Ubyte	0	255	5	sec			
0x0b	Over-voltage delay time		Ubyte	0	255	5	sec			
0x0c	Over-voltage detection		Uword	0	65535	4500	mV			
0x0e	Over-voltage recovery		Uword	0	65535	4350	mV			
Security	Codes	0x0a	0x00	Seal to Unseal code[0]	Hword	0x0	0xffff	0x1234	-	
			0x02	Seal to Unseal code[1]	Hword	0x0	0xffff	0x5678	-	
LogInfo	LogInfo	0x0b	0x00	Max Voltage initial value	Uword	0	65535	2900	mV	
			0x02	Min Voltage initial value	Uword	0	65535	4450	mV	
			0x04	Update difference Voltage	Ubyte	0	255	20	mV	
			0x05	Update difference Current	Ubyte	0	255	50	mA	
			0x06	Max Current initial value	Sword	-32768	32767	0	mA	
			0x08	Min Current initial value	Sword	-32768	32767	0	mA	
			0x0a	Max Temperature initial value	Sword	-32768	32767	150	0.1°C	
			0x0c	Min Temperature initial value	Sword	-32768	32767	350	0.1°C	
			0x0e	Update difference Temperature	Ubyte	0	255	50	0.1°C	
			0x0f	Update minimum interval	Ubyte	0	255	20	sec	
THMtable	THMtable	0x0c	0x00~0f	Thermistor input threshold[0] - [7]	Sword	-32768	32767	-	-	
			0x10~1f	Thermistor coefficient[0][0] - [2][1]	Sword	-32768	32767	-	-	
		0x0d	0x00~1f	Thermistor coefficient[2][2] - [7][2]	Sword	-32768	32767	-	-	
		0x0e	0x00~02	Thermistor shift coefficient[0] - [2]	Ubyte	0	255	-	-	
OCV	OCV	0x14	0x03	Thermistor function setting	Hbyte	0x0	0xff	0xff	-	
			0x12	NoOcvVoltage	Uword	0	65535	0	mV	
			0x14	NoOcvVoltRange	Ubyte	0	255	0	mV	
	RCAP	0x15	0x05	Rcap correction threshold	Ubyte	0	255	5	%	
			0x0e	Force Rcap correction threshold	Ubyte	0	255	80	%	
	OCVtable	0x18	0x00~1f	OcvTable[0] - [15]	Uword	0	65535	-	mV	
			0x19	0x00~07	OcvTable[16] - [19]	Uword	0	65535	-	mV
			0x08~1f	OcvSoc[0] - [11]	Hword	0x0	0xffff	-	-	
	0x1a	0x00~0f	OcvSoc[12] - [19]	Hword	0x0	0xffff	-	-		
	Lifetime	Lifetime	0x70	0x00	MaxVoltage	Uword	0	65535	-	mV
0x02				MinVoltage	Uword	0	65535	-	mV	
0x04				BatHiAlertCount	Ubyte	0	255	-	count	
0x05				BatLoAlertCount	Ubyte	0	255	-	count	
0x06				MaxCurrent	Sword	-32768	32767	-	mA	
0x08				MinCurrent	Sword	-32768	32767	-	mA	
0x0a				OverChgCurrCount	Ubyte	0	255	-	count	
0x0b				OverDsgCurrCount	Ubyte	0	255	-	count	
0x0c				MaxTemperature	Sword	-32768	32767	-	0.1°C	
0x0e				MinTemperature	Sword	-32768	32767	-	0.1°C	
0x10				OverTempCount	Ubyte	0	255	-	count	
0x11				UnderTempCount	Ubyte	0	255	-	count	

Data Flash List

Group	Category	Class	Offset	Name	Data Type	Min value	Max Value	Default Value	Unit
User Calibration	User Calib	0xf0	0x00	Correction Factor Flag	Hword	0x0	0xffff	0xffff	-
			0x06	T-Gain	Sbyte	-128	127	-1	-
			0x07	T-Offset	Sbyte	-128	127	-1	-
			0x08	THM-Gain	Sbyte	-128	127	-1	-
			0x09	THM-Offset	Sbyte	-128	127	-1	-
			0x0a	I-Gain	Sword	-32768	32767	-1	-
			0x0c	I-Offset	Sword	-32768	32767	-1	-
			0x0e	V-Gain	Sword	-32768	32767	-1	-
			0x12	V-Offset	Sword	-32768	32767	-1	-
User NVM	Manufacture	0xf1	0x00~1f	ManufactureA[0] - [31]	Hbyte	0x0	0xff	0xff	-
		0xf2	0x00~1f	ManufactureB[0] - [31]	Hbyte	0x0	0xff	0xff	-
		0xf3	0x00~1f	ManufactureC[0] - [31]	Hbyte	0x0	0xff	0xff	-

Access mode

This IC provides three kind of security modes to control the internal memory access permission

Data Flash Access

Security mode	Manufacture A/B/C	Data Flash	Security
SEALED	Read	None	None
UNSEALED	Read/Write	Read/Write	None
FULL ACCESS	Read/Write	Read/Write	Read/Write

TEST CIRCUIT

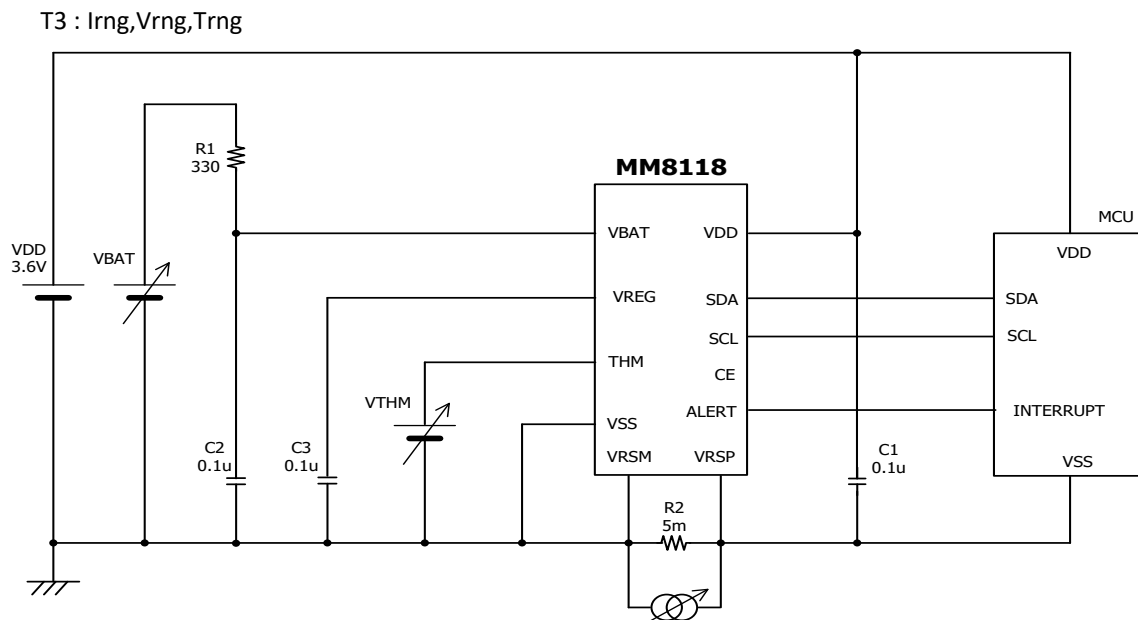
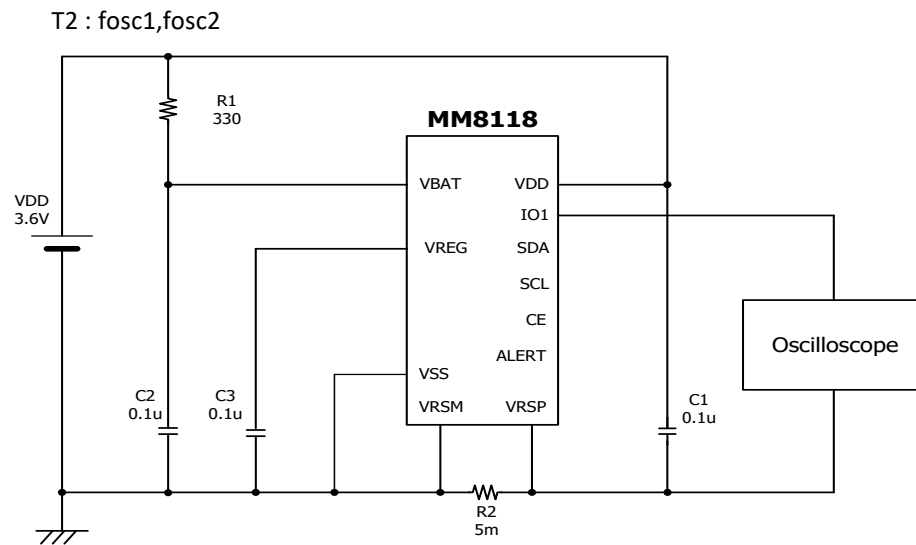
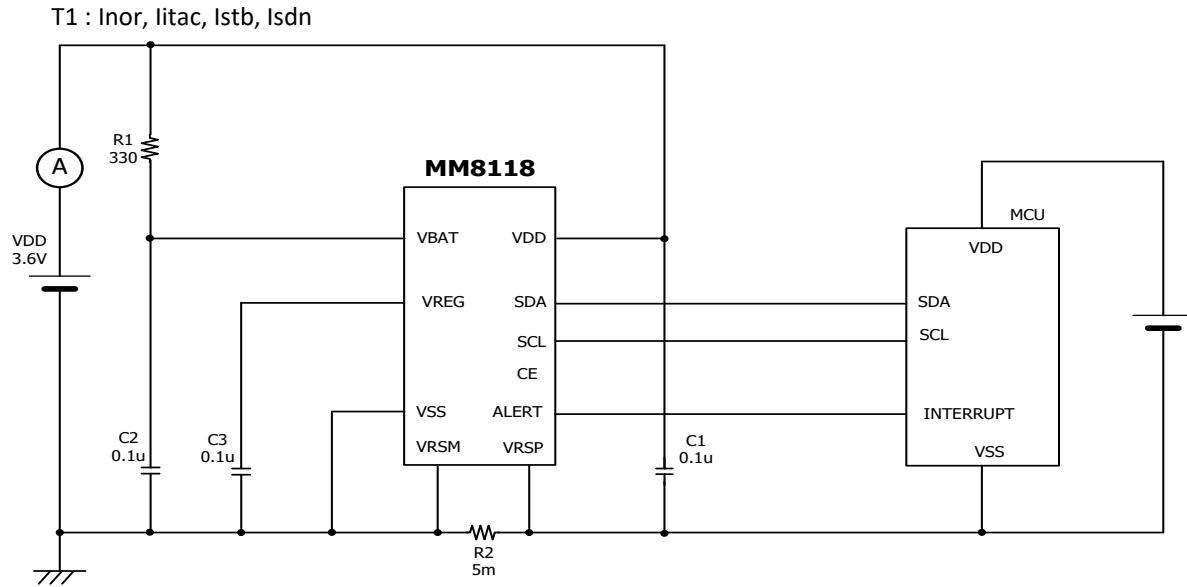

TEST CIRCUIT

T4 : Vreg

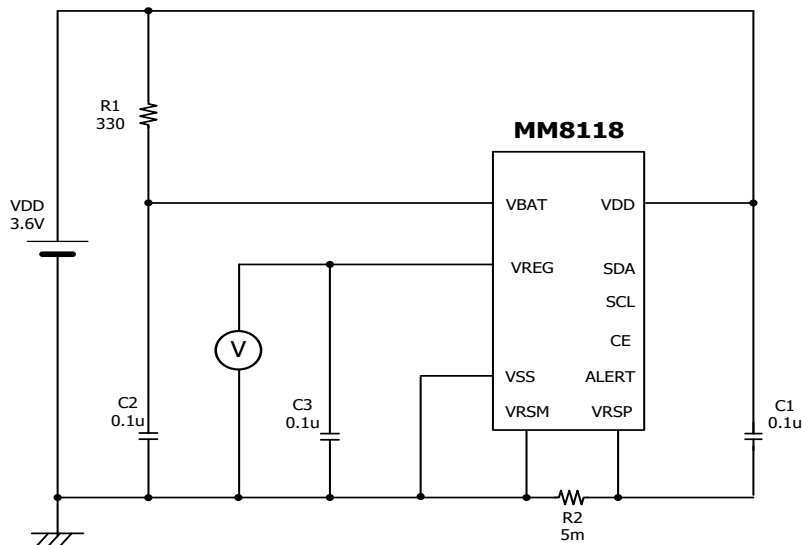

T5 : Pcell

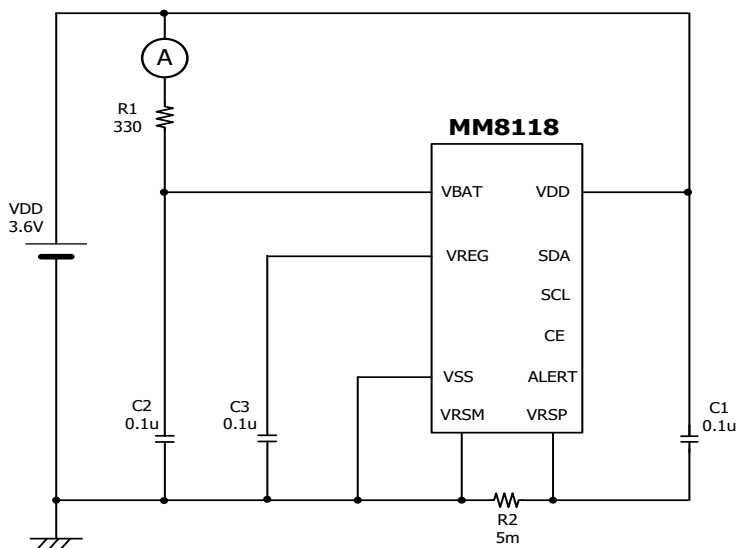

T6 : Vol,Voh

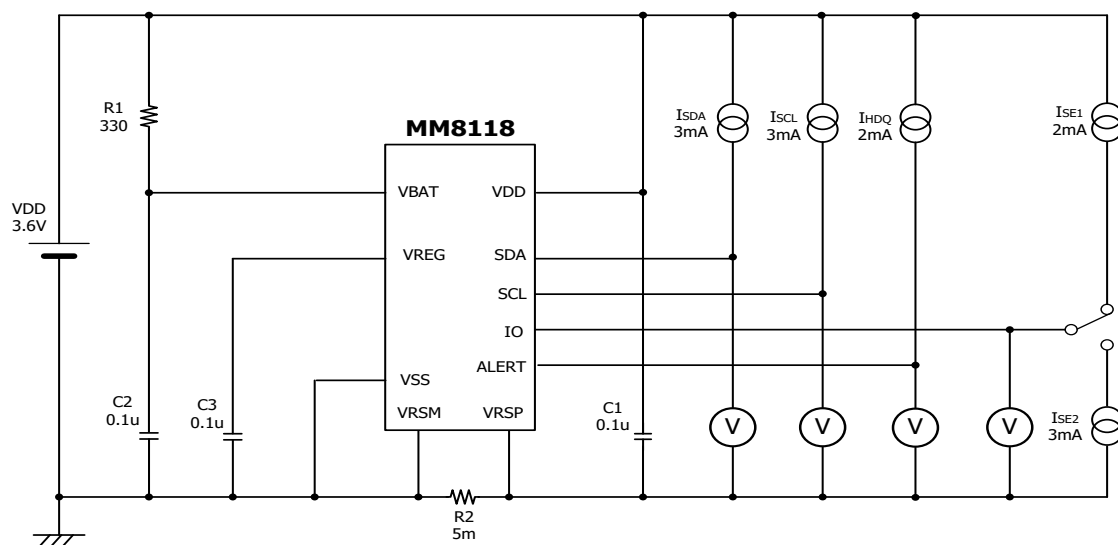

TEST CIRCUIT

T7 : li

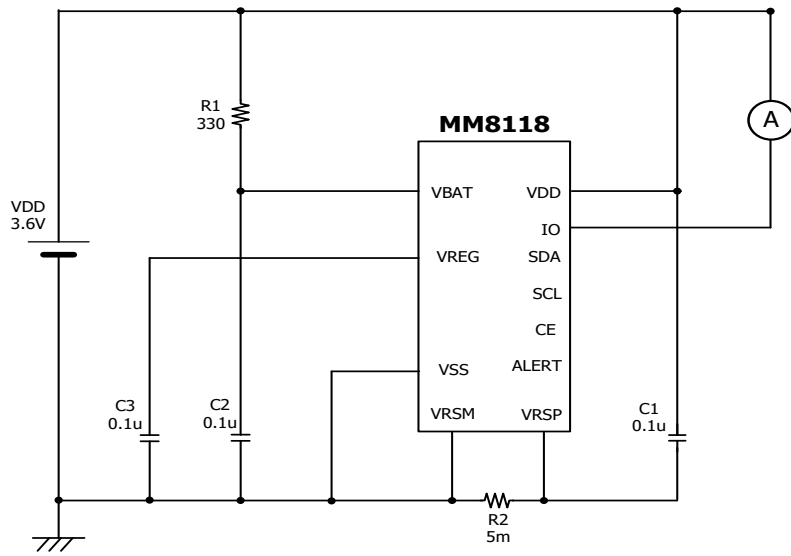

T8 : Digital test

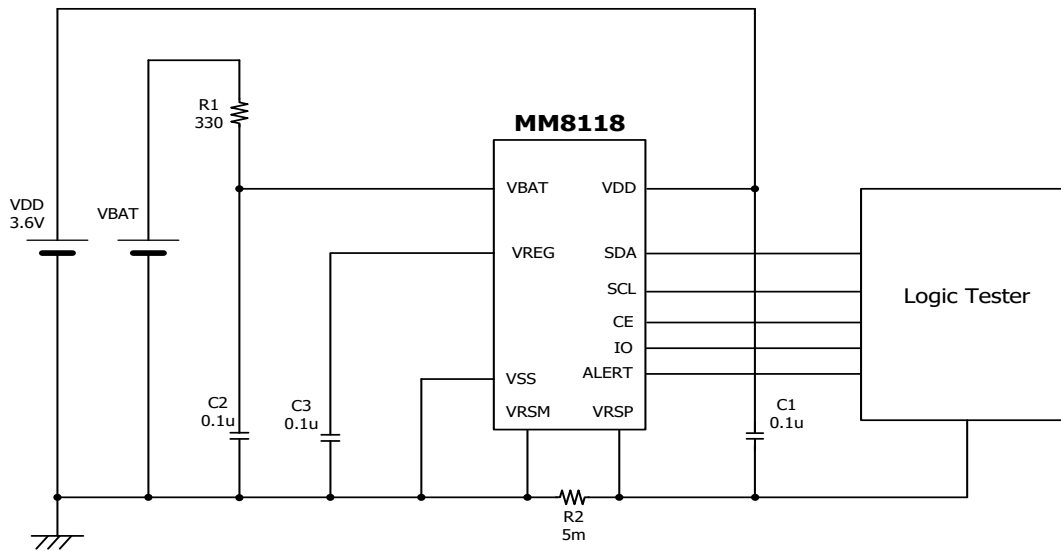

TYPICAL APPLICATION CIRCUIT

Example of the system side

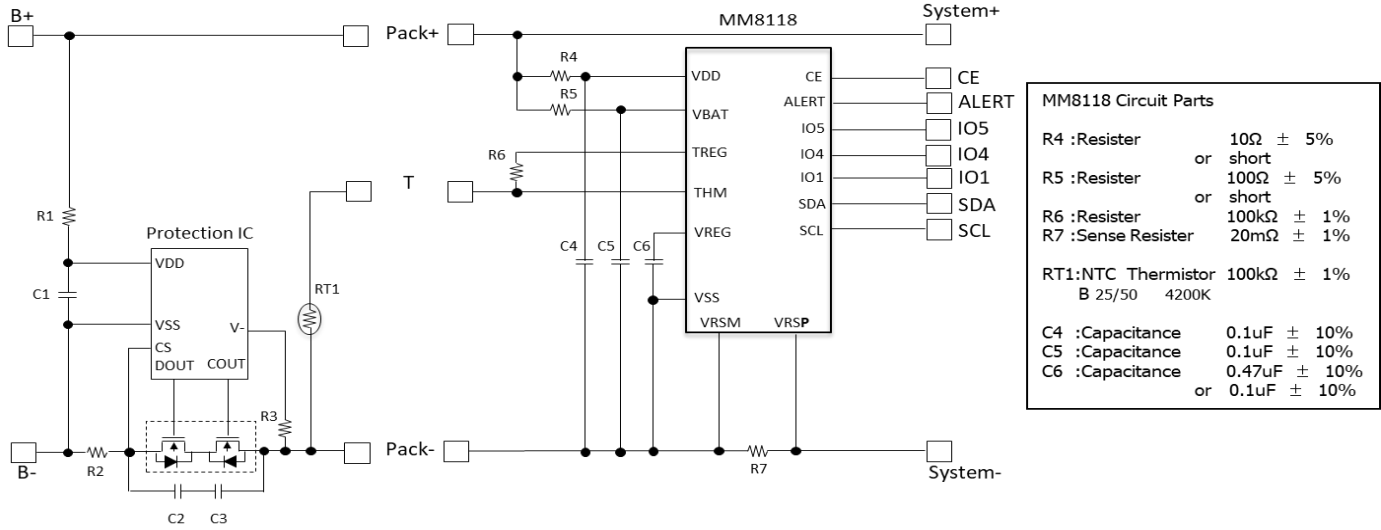

DIMENSIONS

PACKAGE : WLCSP-15A

UNIT	mm
------	----

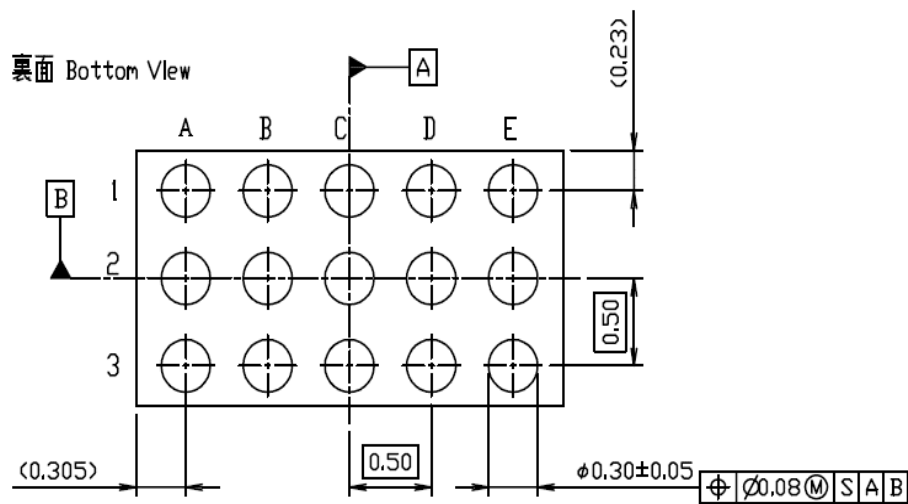
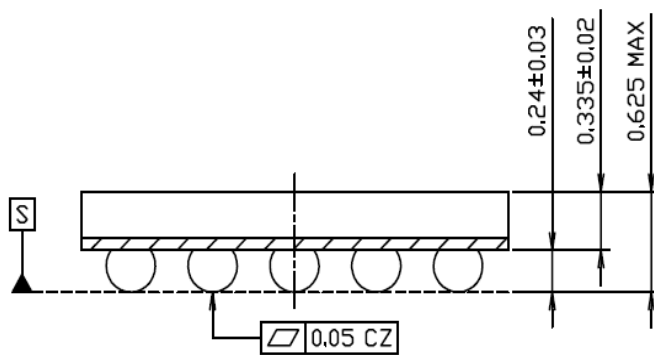
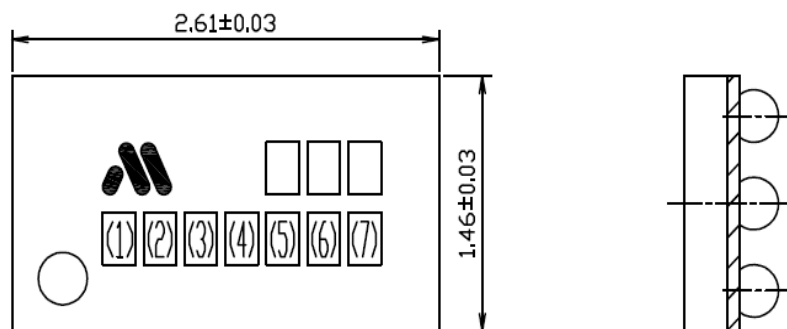

NOTES

【Safety Precautions】

- Though Mitsumi Electric Co., Ltd. (hereinafter referred to as "Mitsumi") works continually to improve our product's quality and reliability, semiconductor products may generally malfunction or fail. Customers are responsible for complying with safety standards and for providing adequate designs and safeguards for their hardware, software and systems which minimize risk and avoid situations in which a malfunction or failure of this product could cause loss of human life, bodily injury, or damage to property, including data loss or corruption. Before customers use this product, create designs including this product, or incorporate this product into their own applications, customers must also refer to and comply with (a) the latest versions or all of our relevant information, including without limitation, product specifications, data sheets and application notes for this product and (b) the user's manual, handling instructions or all relevant information for any products which is to be used, or combined with this products. Customers are solely responsible for all aspects of their own product design or applications, including but not limited to (a) determining the appropriateness of the use of this product in such design or applications; (b) evaluating and determining the applicability of any information contained in this document, or in charts, diagrams, programs, algorithms, sample application circuits, or any other referenced documents; and (c) validating all operating parameters for such designs and applications. Mitsumi assumes no liability for customers' product design or applications.
- This product is intended for applying to computers, OA units, communication units, instrumentation units, machine tools, industrial robots, AV units, household electrical appliances, and other general electronic units.

【Precautions for Product Liability Act】

- No responsibility is assumed by us for any consequence resulting from any wrong or improper use or operation, etc. of this product.

【ATTENTION】

- This product is designed and manufactured with the intention of normal use in general electronics. No special circumstance as described below is considered for the use of it when it is designed. With this reason, any use and storage under the circumstances below may affect the performance of this product. Prior confirmation of performance and reliability is requested to customers.
 - Environment with strong static electricity or electromagnetic wave
 - Environment with high temperature or high humidity where dew condensation may occur
- This product is not designed to withstand radioactivity, and must avoid using in a radioactive environment.
- This specification is written in Japanese and English. The English text is faithfully translated into the Japanese. However, if any question arises, Japanese text shall prevail.