

## Analog Front End IC

# MM3609

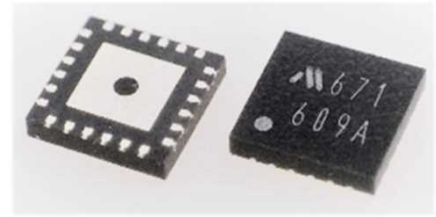

### Outline

This IC is analog front end IC which converts analog signal output from the sensor to digital signal, conducts digital signal processing and outputs to the host such as microcontroller etc. with digital transmission. It responds to a wide variety of sensors.

### Applications

Products that amplify and digitally convert minute output signals from various sensors.

- Pressure sensor
- Flow sensor
- Strain gauge

### Features

- ① It has a 24bit $\Delta\Sigma$ ADC with a wide dynamic range.
- ② The correction factor needed for correcting sensor can be stored in the non-volatile memory (NVM) inside IC.
- ③ The communication interface can be chosen from I2C or SPI.
- ④ It has a temperature sensor and is able to correct the temperature characteristics of the exterior sensor.
- ⑤ It has a built-in oscillator and no need external oscillator.
- ⑥ Possible to select effective resolution or data output rate suitable.
- ⑦ Two modes of sensor driving(constant current and constant voltage).
- ⑧ Standby electricity can be reduced significantly by ON/OFF switch for external sensor.

### Specification

ITEM	SPECIFICATION	Unit
Operation supply voltage range	VDD33 : 1.71 to 3.6 VDDIO : 1.14 to 3.6	V
Operation temperature range	-40 to 85	°C
Consumption current	540 650(with Temp. Sensor)	$\mu$ A
Shut down current	Typ. 0.1, Max. 1.0	$\mu$ A
Integral non-linearity	Typ. $\pm 30$	ppm of FSR
Input conversion noise voltage	1.05 *1	$\mu$ Vrms
Data output rate	20 to 2,560	Hz

\*1 Output rate=20Hz, VDD33=VREFP=3.3V, Ta=25°C

### Block Diagram

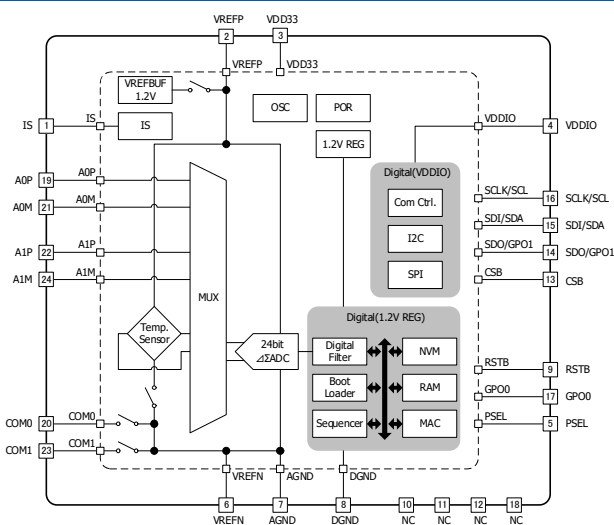

### Package

**PLP-24** (3.0mm□, 0.4mm pitch)

