

Composite regulator with ON/OFF Monolithic IC MM1516

Outline

This IC was developed as a compound power supply and is composed of 3 positive voltage regulator circuits. Regulator output voltage is fixed, and A ranks are set at 2.5V typ. 2.8V typ. and 3.0V typ. Switch pins are provided to control each output. This IC is ideal for use in cellular telephones and the like.

Features

- | | | | |
|------------------------------------|--------------------------------------|--------------------------------|-------------------------------|
| 1. Input/output voltage difference | V_{o1} : 0.25V typ. | V_{o2} : 0.28V typ. | V_{o3} : 0.30V typ. |
| 2. Output noise voltage | V_{o1} : 60 μ Vrms typ. | V_{o2} : 60 μ Vrms typ. | V_{o3} : 60 μ Vrms typ. |
| 3. Output voltage precision | V_{o1}, V_{o2}, V_{o3} : $\pm 3\%$ | | |
| 4. No-load input current | V_{o1} : 250 μ A typ. | V_{o2}, V_{o3} : 500 μ A | |
| 5. Input voltage | 12V max. | | |
| 6. Maximum output current | I_{o1} : 100mA max. | I_{o2} : 100mA max. | I_{o3} : 150mA max. |
| 7. Output ON/OFF control | High: ON, Low: OFF | | |

Package

VSOP-8B

Applications

1. Cellular telephones, PHS
2. Video cameras
3. Portable communications equipment
4. Battery-powered portable equipment

Pin Assignment

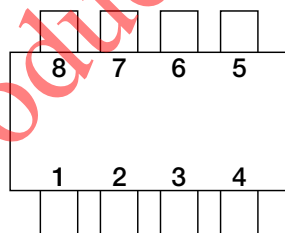

VSOP-8B
(TOP VIEW)

1	PS1	5	V_{o3}
2	PS2/3	6	V_{o2}
3	NC	7	V_{o1}
4	V_{IN}	8	GND

Pin Description

Pin No.	Pin name	Functions	Internal equivalent circuit						
1 2	PSn	ON/OFF-Control Pin <table border="1"> <tr> <td>V_{SPn}</td> <td>Output</td> </tr> <tr> <td>L</td> <td>OFF</td> </tr> <tr> <td>H</td> <td>ON</td> </tr> </table> Connect CONT-Terminal With V_{IN} , When It Is Not Used.	V_{SPn}	Output	L	OFF	H	ON	
V_{SPn}	Output								
L	OFF								
H	ON								
8	GND	GND Pin							
5 6 7	V_{o1-3}	Regulator Output Pin							
4	V_{IN}	Voltage-supply Pin							

Products to be discontinued

Equivalent Circuit Diagram

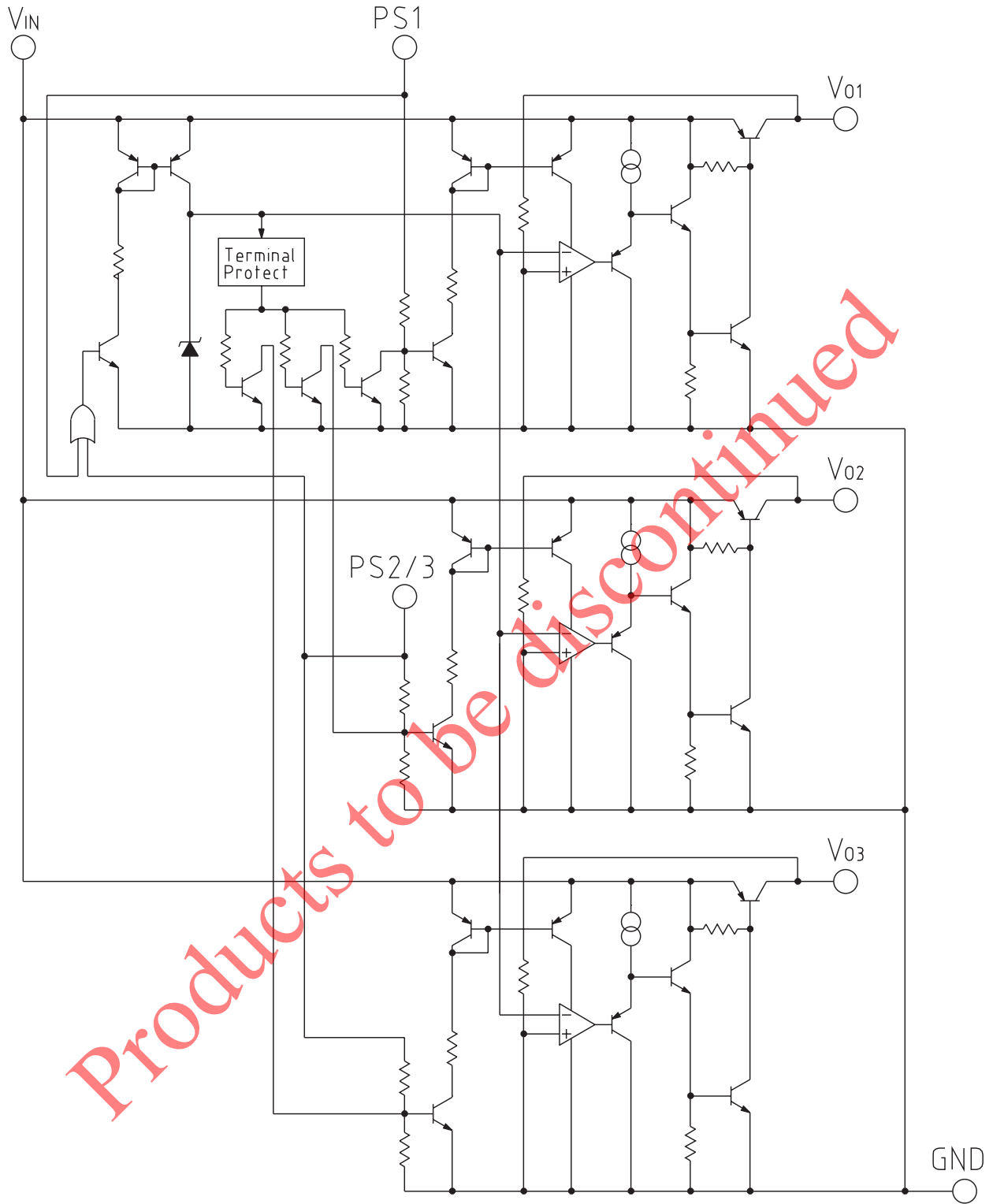

Absolute Maximum Ratings

Item	Symbol	Ratings	Unit
Operating Temperature	T _{OPR}	-20~+75	°C
Storage Temperature	T _{STG}	-40~+125	°C
Supply Voltage	V _{IN}	-0.3~+12	V
Output Current	I _o (1,2)	100	mA
	I _o (3)	150	
Power Dissipation	P _d	300 (*1)	mW
		500 (*2)	

Note1: *1 Alone measurement

Note2: *2 When mounted on glass epoxy board (40 × 40 × 1.6mm)

Recommended Operating Conditions

Item	Symbol	Ratings	Unit
Operating Temperature	T _{OP}	-20~75	°C
Regulator Output Current	I _o (1,2)	0~70	mA
	I _o (3)	0~100	
Operating Voltage	V _{OP}	1.8~8	V

Electrical Characteristics (T_a=25°C, V_{IN}=, C_{IN}=2.2μ, C_{VO} (n) =2.2μF Funless otherwise spec.)

Item	Symbol	Measurement conditions	Min.	Typ.	Max.	Unit	
Supply Current(off)	I _{IN}	V _{PS1} =V _{PS2/3} =0V		0	3	μA	
Supply Current1~3 (1 circuit's worth is the same as 3 circuits)	I _{IN1-3}	No load				μA	
		I _{IN1}	V _{PS1} =3V, V _{PS2/3} =0V		250		370
		I _{IN2/3}	V _{PS2} =3V, V _{PS1/3} =0V		500		740

Item	Symbol	Measurement conditions	Min.	Typ.	Max.	Unit
Vo1						
Output Voltage	Vo1	I _{o1} =30mA	2.42	2.50	2.58	V
Input-Output Differential Voltage	Vdmin.1	V _{IN} =2.3V, I _{o1} =30mA		0.1	0.25	V
Load Regulation	ΔVLo1	I _{o1} =0~70mA		30	60	mV
Line Regulation	ΔVLi1	V _{IN} =4.0~8.0V, I _{o1} =30mA		10	25	mV
Vo Temperature Coefficient (*)	ΔVo1/ΔT	T _j =-20~75°C, I _{o1} =30mA		±100		ppm/°C
Ripple Rejection (*)	RR1	f=120Hz, V _{ripple} =1V _{P-P} I _{o1} =30mA	50	60		dB
Output Noise Voltage (*)	Vn1	f=10Hz~10kHz, I _{o1} =30mA		60	90	μVrms
Output Delay Time (*)	TdH1	I _{o1} =30mA, V _{PS1} =0 →4V, V _{PS2/3} =0V		0.04	0.15	ms
Vo2						
Output Voltage	Vo2	I _{o2} =30mA	2.72	2.80	2.88	V
Input-Output Differential Voltage	Vdmin.2	V _{IN} =2.6V, I _{o2} =30mA		0.1	0.25	V
Load Regulation	ΔVLo2	I _{o2} =0~70mA		30	60	mV
Line Regulation	ΔVLi2	V _{IN} =4.0~8.0V, I _{o2} =30mA		10	25	mV
Vo Temperature Coefficient (*)	ΔVo2/ΔT	T _j =-20~75°C, I _{o2} =30mA		±100		ppm/°C
Ripple Rejection (*)	RR2	f=120Hz, V _{ripple} =1V _{P-P} I _{o2} =30mA	50	60		dB
Output Noise Voltage (*)	Vn2	f=10Hz~10kHz, I _{o2} =30mA		60	90	μVrms
Output Delay Time (*)	TdH2	I _{o2} =30mA, V _{PS2/3} =0 →4V V _{PS1} =0V		0.04	0.15	ms
Vo3						
Output Voltage	Vo3	I _{o3} =80mA	2.92	3.00	3.08	V
Input-Output Differential Voltage	Vdmin.3	V _{IN} =2.8V, I _{o3} =80mA		0.15	0.30	V
Load Regulation	ΔVLo3	I _{o3} =0~100mA		30	60	mV
Line Regulation	ΔVLi3	V _{IN} =4.0~8.0V, I _{o3} =30mA		10	25	mV
Vo Temperature Coefficient (*)	ΔVo3/ΔT	T _j =-20~75°C, I _{o3} =30mA		±100		ppm/°C
Ripple Rejection (*)	RR3	f=120Hz V _{ripple} =1V _{P-P} I _{o3} =30mA	50	60		dB
Output Noise Voltage (*)	Vn3	f=10Hz~10kHz, I _{o3} =30mA		60	90	μVrms
Output Delay Time (*)	TdH3	I _{o3} =30mA, V _{PS2/3} =0 →4V		0.04	0.15	ms
PS output control pin						
Low Threshold Voltage	V _{OFF}				0.4	V
High Threshold Voltage	V _{ON}		1.6			V
PS(n) Terminal Current	I _{PS1}	V _{PS1} =1.6V			8	μA
	I _{PS2/3}	V _{PS2/3} =1.6V			16	

Note: This spec is guaranteed by design.

Measuring Circuit

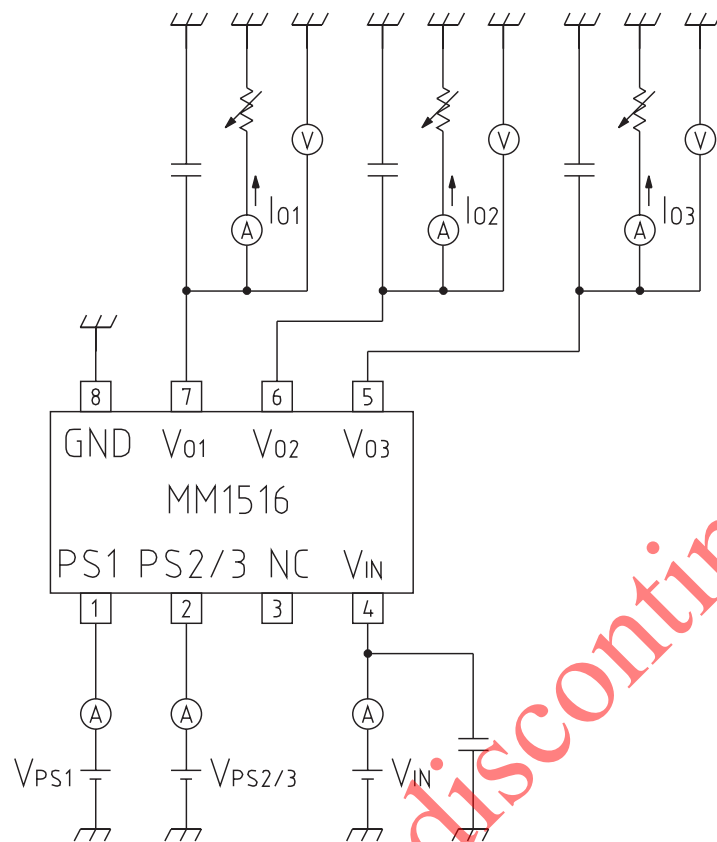

Application Circuits

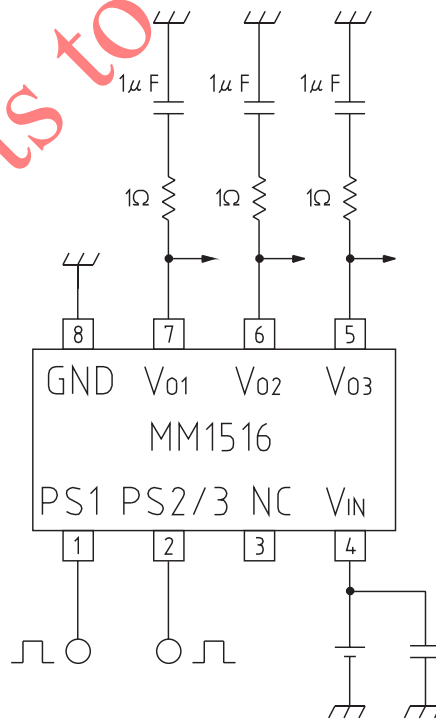

Note: This regulator is not internally compensated and thus requires an external output-capacitor (C_{vo}) for stability.

Characteristics

Input-Output Differential Voltage

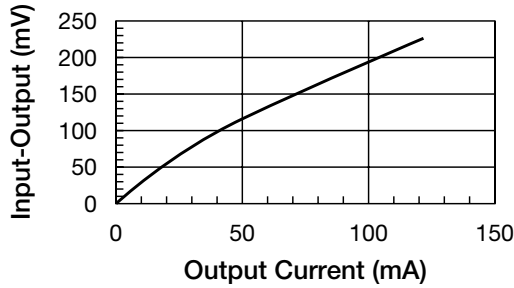

Line Regulation

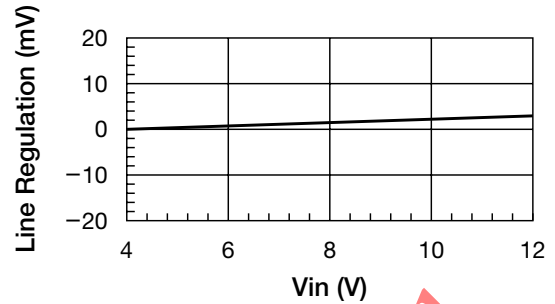

Load Regulation

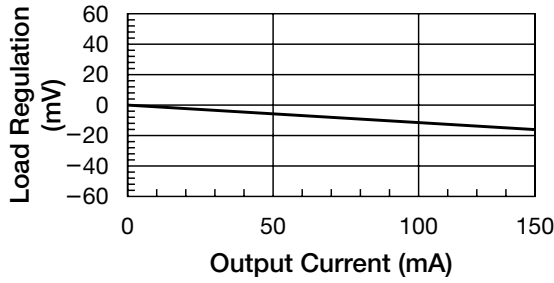

Thermal Shutdown

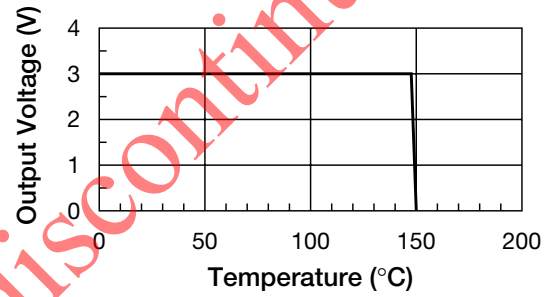

Current Limit

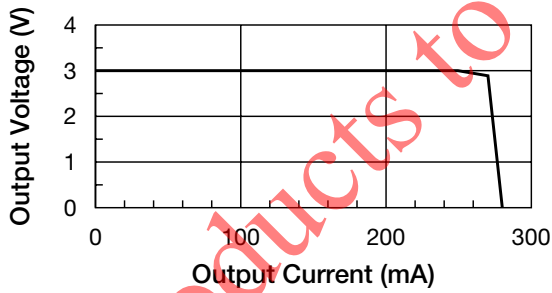

ESR Stable

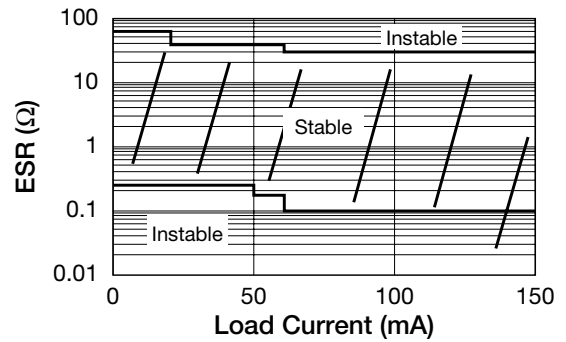

Note: Reference data

Allowable loss

