

High voltage Reset IC with separated sense pin and Release/Detect delay time

PST114/PST11D Series

Overview

This IC is a 40V withstand voltage 1ch voltage detection IC that is ideal for monitoring the voltage of car batteries. The voltage detection accuracy is $\pm 2\%$ including temperature fluctuation, and the output form is Nch open drain output. The Current consumption is 1.7 μA (typ.) And the operating temperature range is -40 to 105°C . The detection delay time and release delay time can be set with external capacitors.

Features

- High withstand voltage
- High accuracy detection
- Low current consumption
- Hysteresis voltage selectable (0.1V to 4.0V)
- Separated sense pin
- Release/Detect delay time

Main specifications

- Absolute maximum rating : -0.3V to 40V
- Operating voltage : 2.7V to 20V
- Operating ambient temperature : -40°C to 105°C
- Detection voltage : 5.0V to 10.0V (0.1V step)
- Detection voltage accuracy : $\pm 2\%$ ($T_a = -40$ to 105°C)
- Hysteresis voltage : 0.1V to 4.0V
- Consumption current : PST114: Typ. $1.7\mu\text{A}$ ($V_{\text{DD}}=3.3\text{V}$, $V_{\text{S}}=16\text{V}$)
PST11D: Typ. $2.3\mu\text{A}$ ($V_{\text{DD}}=3.3\text{V}$, $V_{\text{S}}=16\text{V}$)
- Output type : Open drain
- Output Logic : PST114: Active L
PST11D: Active H
- Detect delay time : Typ. 10ms ($V_{\text{DD}}=3.3\text{V}$, $V_{\text{S}}=13\text{V} \Rightarrow 0\text{V}$, $\text{CDL}=9.1\text{nF}$, $\text{CDH}=9.1\text{nF}$)
- Release delay time : Typ. 10ms ($V_{\text{DD}}=3.3\text{V}$, $V_{\text{S}}=0\text{V} \Rightarrow 13\text{V}$, $\text{CDL}=9.1\text{nF}$, $\text{CDH}=9.1\text{nF}$)
- Additional function : Separated sense pin

Packages

- SOT-26B

Application

- Voltage monitor for car battery
- Voltage monitor for AC / DC converter output voltage





Model Name

P S T 1 1 X X X X X X X

Series name (A) (B) (C) (D) (E) (F)

(A) Function Type	4	Reset output logic Active L
	D	Reset output logic Active H
(B) Hysteresis voltage	A	$V_{TH} \times 0.02 \leq \text{Hysteresis voltage}(\text{typ.}) < V_{TH} \times 0.03$
	B	$V_{TH} \times 0.03 \leq \text{Hysteresis voltage}(\text{typ.}) < V_{TH} \times 0.04$
	C	$V_{TH} \times 0.04 \leq \text{Hysteresis voltage}(\text{typ.}) < V_{TH} \times 0.05$
	D	$V_{TH} \times 0.05 \leq \text{Hysteresis voltage}(\text{typ.}) < V_{TH} \times 0.075$
	E	$V_{TH} \times 0.075 \leq \text{Hysteresis voltage}(\text{typ.}) < V_{TH} \times 0.1$
	F	$V_{TH} \times 0.1 \leq \text{Hysteresis voltage}(\text{typ.}) < V_{TH} \times 0.2$
	G	$V_{TH} \times 0.2 \leq \text{Hysteresis voltage}(\text{typ.}) < V_{TH} \times 0.3$
	H	$V_{TH} \times 0.3 \leq \text{Hysteresis voltage}(\text{typ.}) < V_{TH} \times 0.4$
	J	$V_{TH} \times 0.4 \leq \text{Hysteresis voltage}(\text{typ.}) < V_{TH} \times 0.5$
	K	$V_{TH} \times 0.5 \leq \text{Hysteresis voltage}(\text{typ.}) < V_{TH} \times 0.75$
(C) Reset detection voltage	50	Reset detection voltage range is 5.0V to 10.0V.
	∅	When the detection voltage is 5.0 to 9.9V, specify it with "50" to "99".
	00	When the detection voltage is 10.0V, specify it with "00".
(D) Package	N	SOT-26B
(E) Packing specifications 1	R	R housing (Standard)
(F) Packing specifications 2	H	Embos tape / Halogen free

Block Diagram

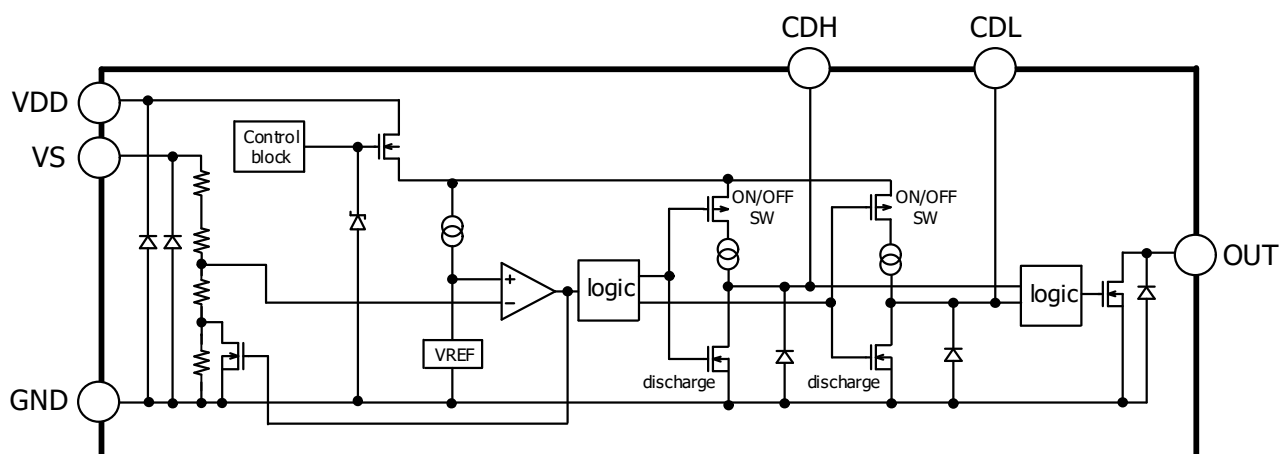



Pin Configuration

- SOT-26B

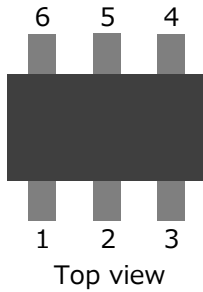

Pin No.	Pin name	Function
1	VDD	Power supply input pin
2	VS	Voltage sensing pin
3	OUT	Output pin
4	CDH	Release delay pin with external capacitor
5	GND	Ground pin
6	CDL	Reset delay pin with external capacitor



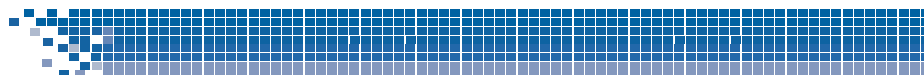

Absolute Maximum Ratings

Item	Symbol	Min.	Max.	Unit
Supply voltage	VDD	-0.3	40	V
VS pin voltage	VS	-0.3	40	V
CDH pin voltage	VCDL	-0.3	5.5	V
CDL pin voltage	VCDH	-0.3	5.5	V
OUT pin voltage	VOUT	-0.3	40	V
OUT pin output current	IOUT	-	20	mA
Storage temperature	Tstg	-55	150	°C
Power dissipation	Pd1	-	150	mW

Recommended Operating Conditions

Item	Symbol	Min.	Max.	Unit
Operating ambient temperature	Topr	-40	105	°C
Operating voltage	Vop	2.7	20	V

Electrical Characteristics

(Ta=-40~105°C, typically value at VDD=3.3V, Ta=25°C, unless otherwise specified *Note1)

Item	Symbol	Conditions	Min.	Typ.	Max.	Unit	Test circuit	
Consumption current	IDD	VDD=3.3V VS=16V	PST114	-	1.7	2.9	μA	B
			PST11D	-	2.3	3.5	μA	B
Output current	IOL	VDD=3.3V VS=0V, VOUT=0.5V	PST114	1	-	-	mA	C
		VDD=3.3V VS=20V, VOUT=0.5V	PST11D	1	-	-	mA	C
Output leakage current	ILEAK	VDD=20V VS=20V, VOUT=20V	PST114	-	-	2	μA	C
		VDD=20V VS=0V, VOUT=20V	PST11D	-	-	2	μA	C
Reset transfer delay time	TdHLC1	VDD=3.3V, VS=13V→0V CDL=open, CDH=open	35	80	230	μs	D	
Reset delay time	TdHLC2	VDD=3.3V, VS=13V→0V CDL=9.1μF, CDH=9.1μF	6.9	10.0	15.7	ms	E	
Release transfer delay time	TdLHC1	VDD=3.3V, VS=0V→13V CDL=open, CDH=open	20	60	200	μs	D	
Release delay time	TdLHC2	VDD=3.3V, VS=0V→13V CDL=9.1μF, CDH=9.1μF	6.9	10.0	15.7	ms	E	
VS pin resistance	RVS1	VDD=3.3V VS=14V	30	60	200	MΩ	E	

*Note1: Final inspection is tested Ta=25°C only. Temperature ranges other than 25 °C is guaranteed by design.





Electrical Characteristics

(Ta=-40~105°C, typically value at VDD=3.3V, Ta=25°C, unless otherwise specified *Note1)

Item	Symbol	Conditions	Min.	Typ.	Max.	Unit	Test circuit	
Reset voltage	VTH	VDD=3.3V VS:H→L	$V_{TH} \times 0.98$	VTH	$V_{TH} \times 1.02$	V	A	
Hysteresis voltage	ΔV_{TH}	VDD=3.3V $\Delta V_{TH} = V_{RE} - V_{TH}$	-	ΔV_{TH}	-	V	A	
Release voltage	VRE	VDD=3.3V VS:L→H	$\Delta V_{TH} < 0.1V$	$V_{TH} \times 0.98 + (\Delta V_{TH} - 0.1)$	$V_{TH} + \Delta V_{TH}$	$V_{TH} \times 1.02 + (\Delta V_{TH} + 0.1)$	V	A
			$\Delta V_{TH} \geq 0.1V$	$V_{TH} \times 0.98 + (\Delta V_{TH} \times 0.9)$	$V_{TH} + \Delta V_{TH}$	$V_{TH} \times 1.02 + (\Delta V_{TH} \times 1.1)$	V	A

*Note1: Final inspection is tested Ta=25°C only. Temperature ranges other than 25 °C is guaranteed by design.





Test Circuit

(A)

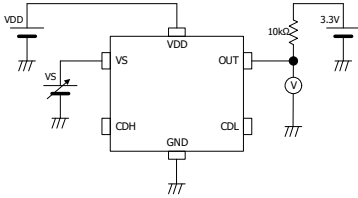

(B)

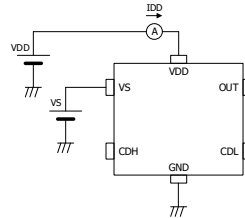

(C)

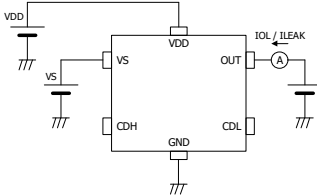

(D)

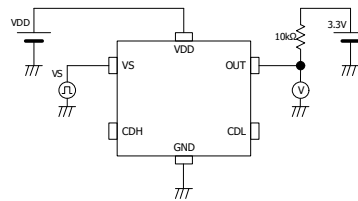

(E)

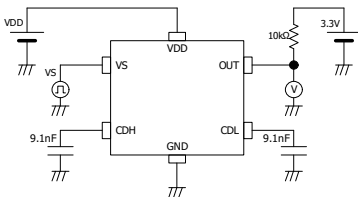

(F)

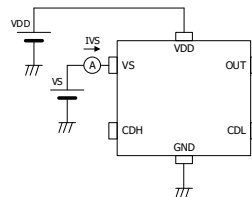

Application Circuit

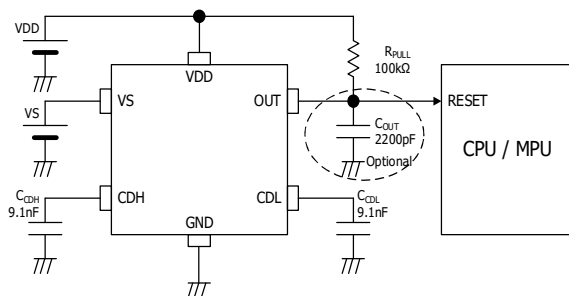

**Note**

1. The typical application circuit is not guaranteed for a set applications. It has to test sufficiently in a set applications.
2. In the event a problem which may affect industrial property or any other rights of us or a third party is encountered during the use of information described in these circuit, Mitsumi shall not be liable for any such problem, nor grant a license therefore.
3. For Surge and over voltage protection, recommend to use ESD protection device such as baristor at battery pin (ex. VDD, VS).
4. If the hysteresis voltage is small, the OUT pin may chatter. It is recommended to connect a about 2200pF capacitor to the OUT pin to prevent chattering.
5. At VDD start-up, the output may be undefined during the transfer delay. After VDD exceeds 2.7V, It is recommended to set the output to wait during reset and release transfer delay time. When VDD falls, the OUT pin may be undefined at 2.7V or less.
6. It is recommended to connect a 100pF~47000pF capacitor to the CDH pin and CDL pin.
7. Between next to each other pin of PST1xx (SOT-26B), it has parasitic capacitance due to Package and IC round, max 0.2pF . Because of next to VS pin and OUT pin, when it happened VS pin voltage is changing rapidly, it afford between pin, it happened over / under shoot. To decrease of over / under shoot ,it recommend to connect the capacitor COUT at OUT pin. When it may have parasitic capacitance to OUT pin round at set board, it improves layout pattern, separating from changing rapidly node or adding shield of ground.





Timing Chart

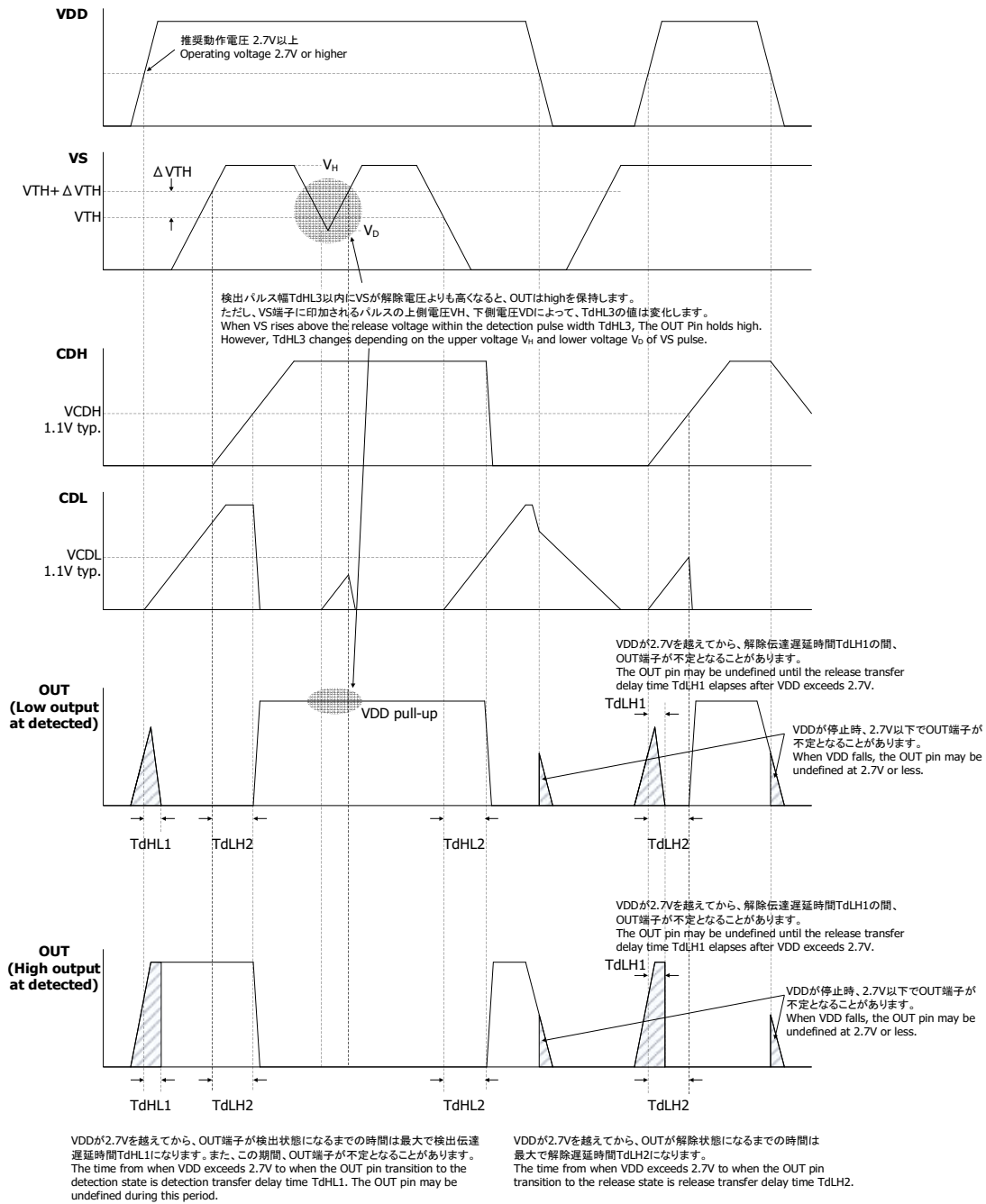

* T_{dHL3} can be calculated by the following formula.

$$T_{dHL3} [\text{ms}] = KHL \times CCDL [\text{nF}]$$

KHL is the detection delay time coefficient.

CCDL is the capacitance value of the capacitor connected to the CDL terminal.

KHL is Min. 0.76, Typ. 1.09, Max. 1.70.



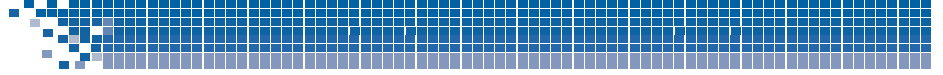

Typical Performance Characteristics

PST114N78N : $V_{TH}=7.8V$, $\Delta V_{TH}=0.4V$

Reset voltage - VS

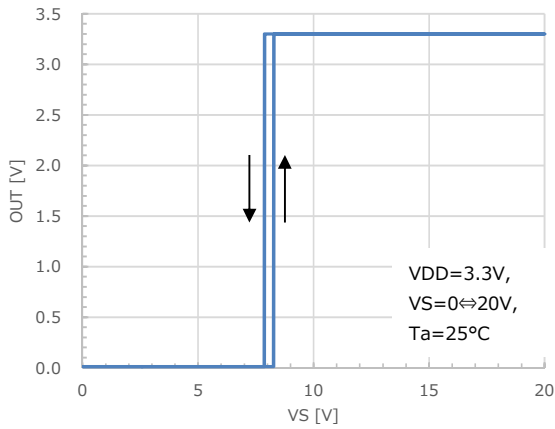

OUT pin voltage - VDD

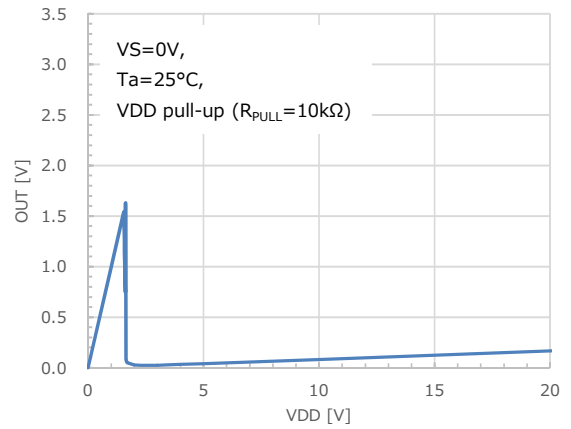

Output leakage current - OUT

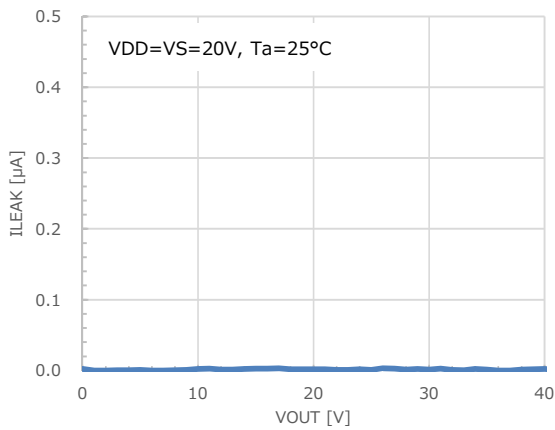

Reset delay time - CDL capacitor C_{CDL}

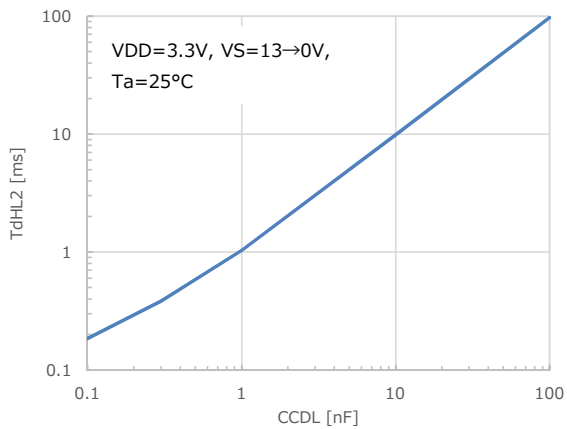

Release delay time - CDH capacitor C_{CDH}

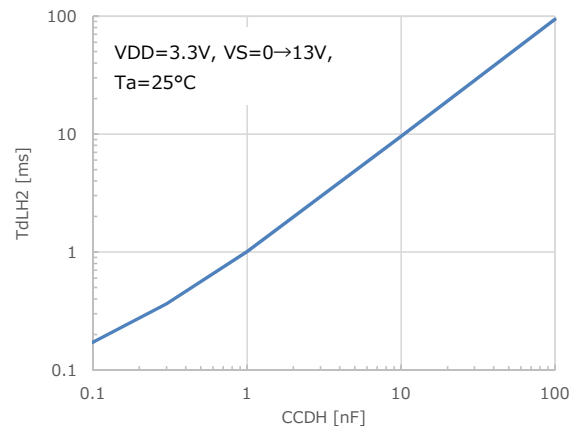

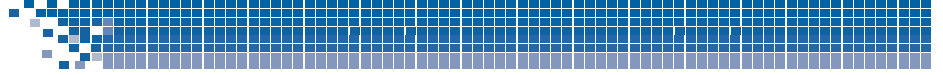

Typical Performance Characteristics

PST114N78N : $V_{TH}=7.8V$, $\Delta V_{TH}=0.4V$

Reset voltage - VDD

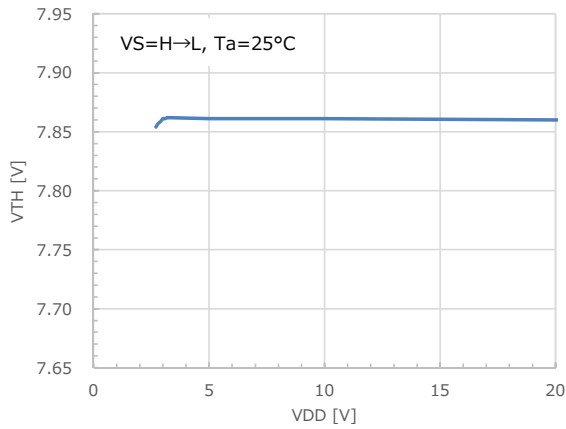

Hysteresis voltage - VDD

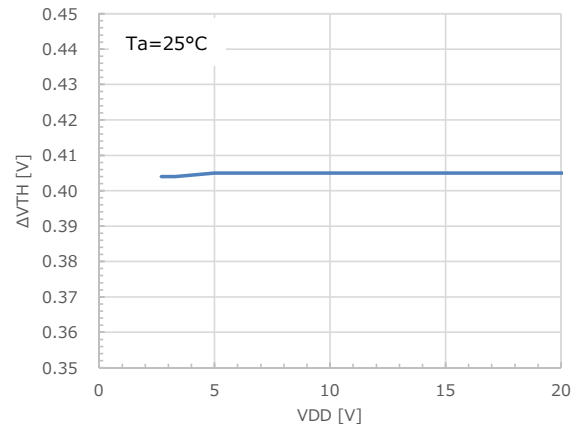

Supply current - VDD

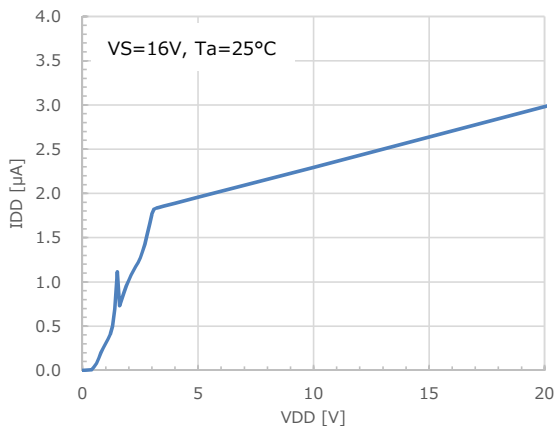

Output current - VDD

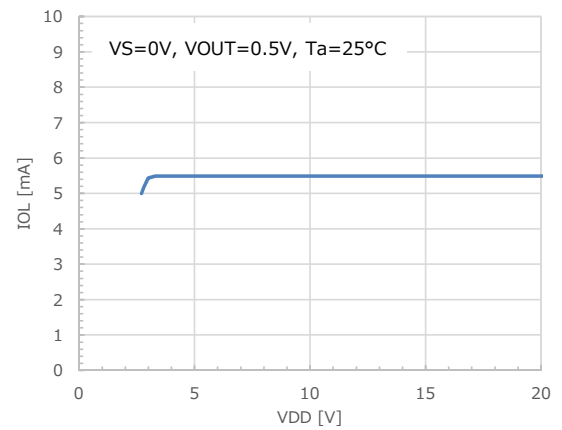

Reset transfer delay time - VDD

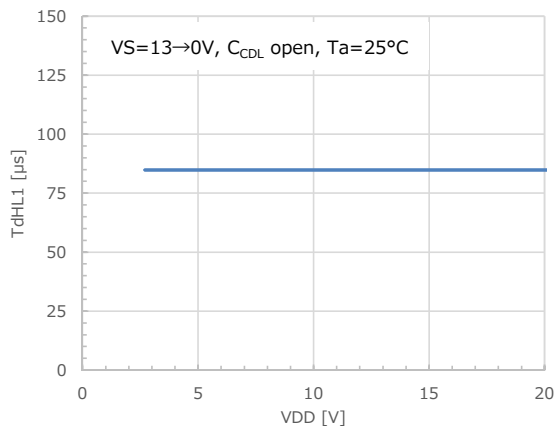

Reset delay time - VDD

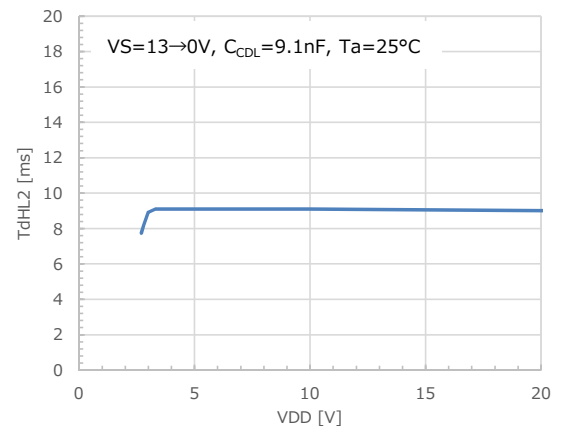



Typical Performance Characteristics

PST114N78N : $V_{TH}=7.8V$, $\Delta V_{TH}=0.4V$

Release transfer delay time - VDD

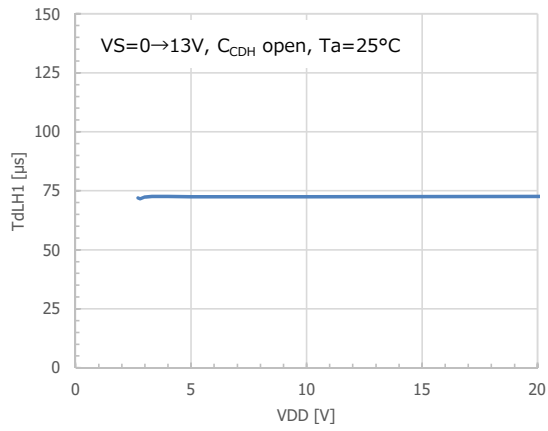

Release delay time - VDD

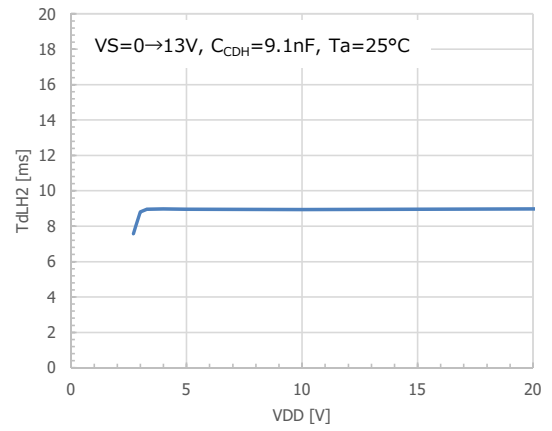



Typical Performance Characteristics

PST114N78N : $V_{TH}=7.8V$, $\Delta V_{TH}=0.4V$

Reset voltage - Temperature

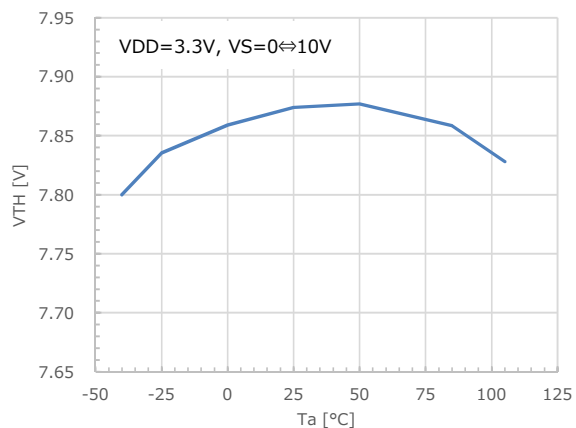

Hysteresis voltage - Temperature

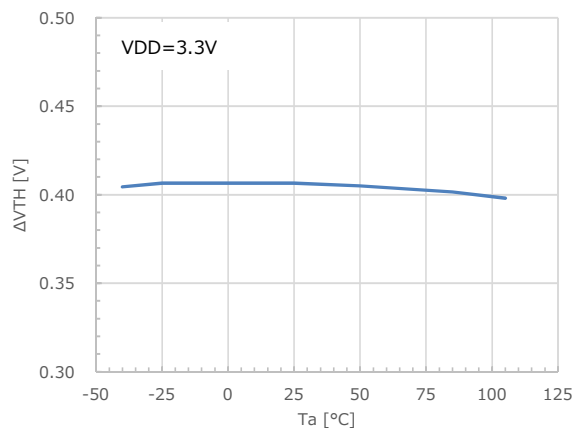

Supply current - Temperature

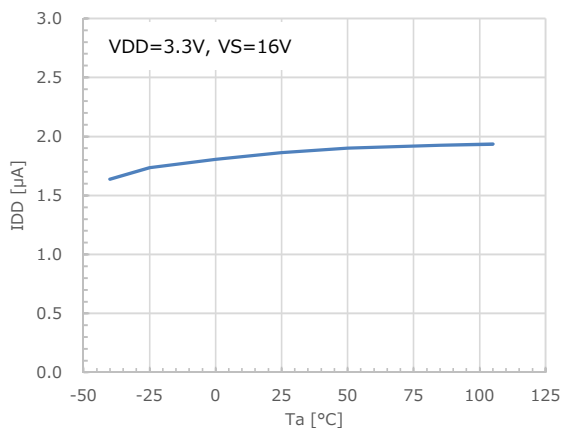

Output current - Temperature

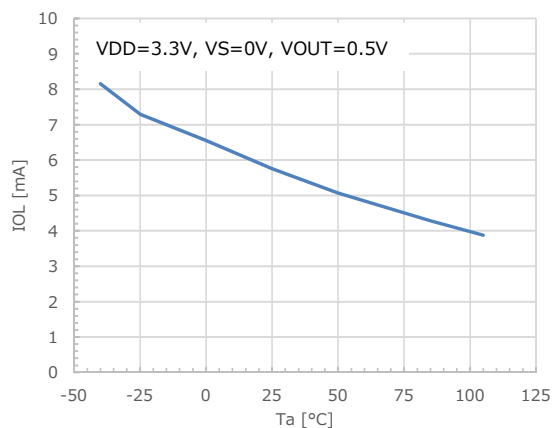

Output leakage current - Temperature

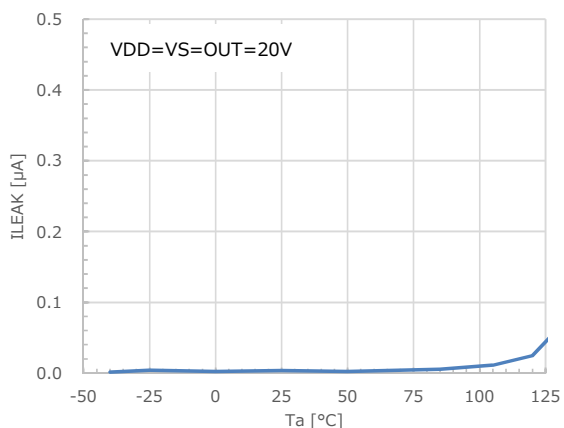



Typical Performance Characteristics

PST114N78N : $V_{TH}=7.8V$, $\Delta V_{TH}=0.4V$

Reset transfer delay time - Temperature

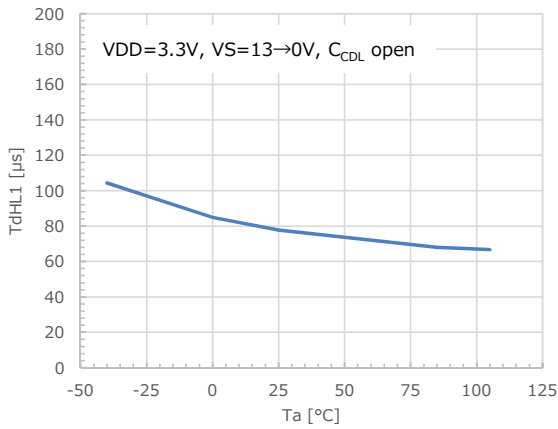

Reset delay time - Temperature

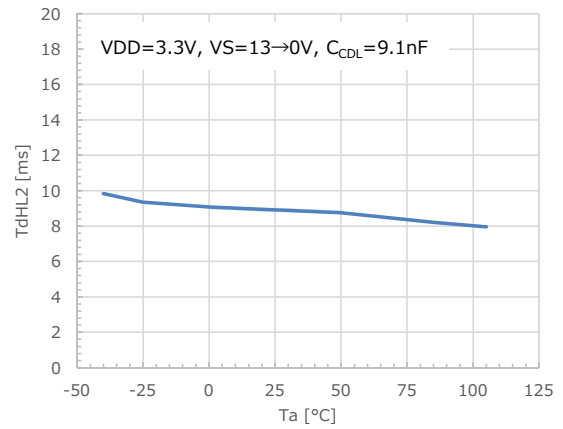

Release transfer delay time - Temperature

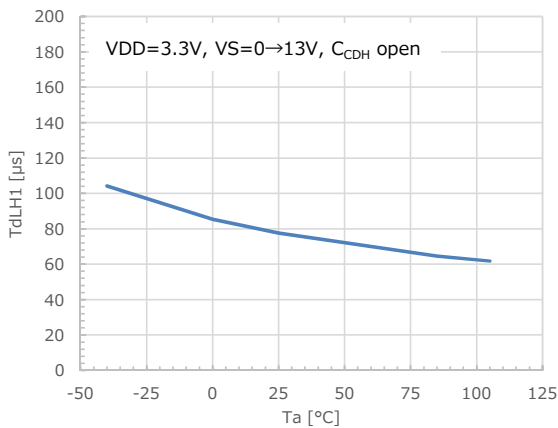

Release delay time - Temperature

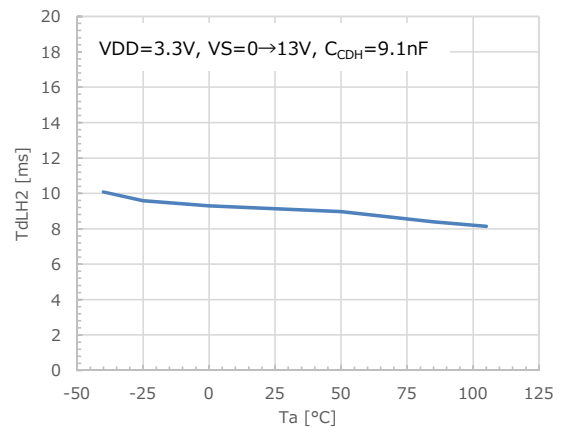

VS pin resistance - Temperature

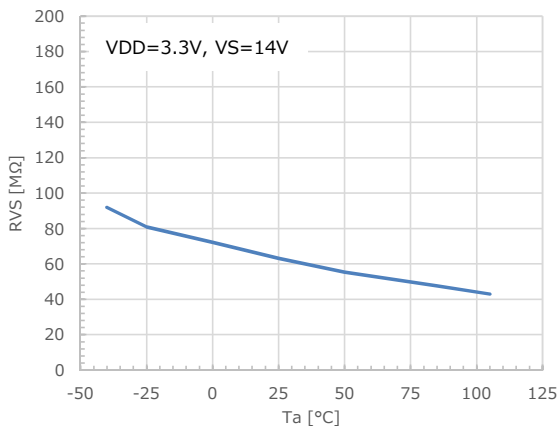



Typical Performance Characteristics

PST114N78N : $V_{TH}=7.8V$, $\Delta V_{TH}=0.4V$

Waveform (VS rising)

VDD=3.3V, VS=0→13V, CCDH=9.1nF,
CCDL=9.1nF, RPULL=10kΩ, COU=220pF, Ta=25°C

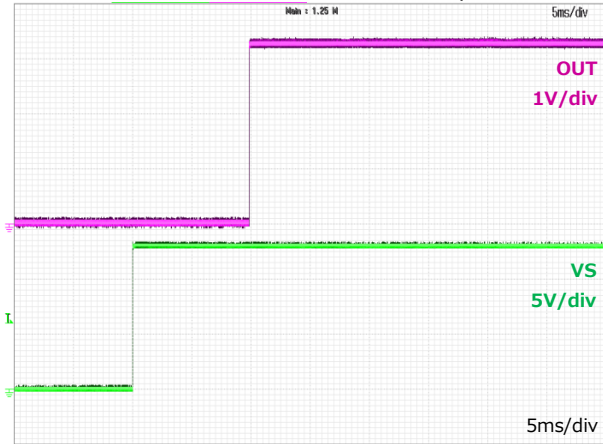

Waveform (VS falling)

VDD=3.3V, VS=13→0V, CCDH=9.1nF,
CCDL=9.1nF, RPULL=10kΩ, COU=220pF, Ta=25°C

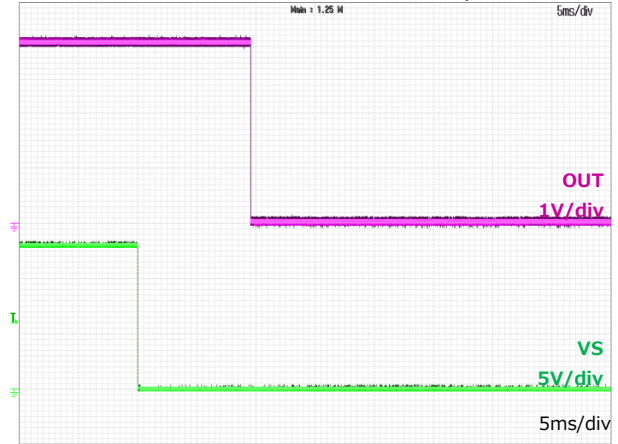

Waveform (VDD rising VS=0V)

VDD=0→3.3V, VS=0V, CCDH=9.1nF,
CCDL=9.1nF, RPULL=10kΩ, COU=220pF, Ta=25°C

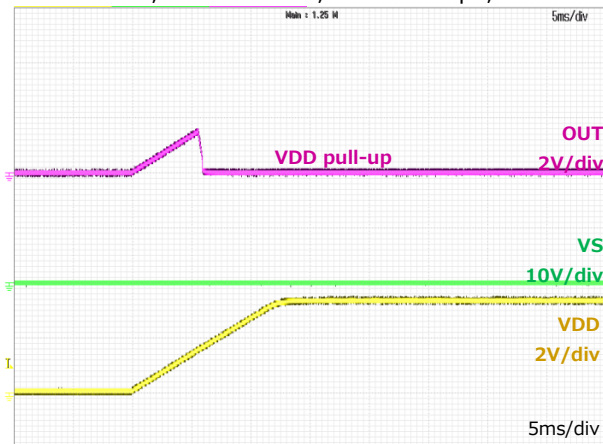

Waveform (VDD falling VS=0V)

VDD=3.3→0V, VS=0V, CCDH=9.1nF,
CCDL=9.1nF, RPULL=10kΩ, COU=220pF, Ta=25°C

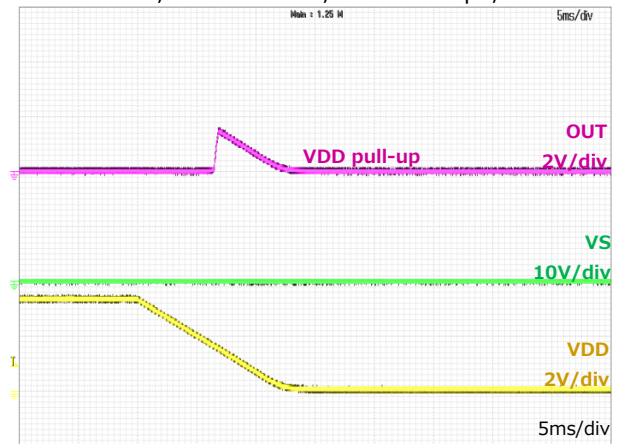

Waveform (VDD rising VS=13V)

VDD=0→3.3V, VS=13V, CCDH=9.1nF,
CCDL=9.1nF, RPULL=10kΩ, COU=220pF, Ta=25°C

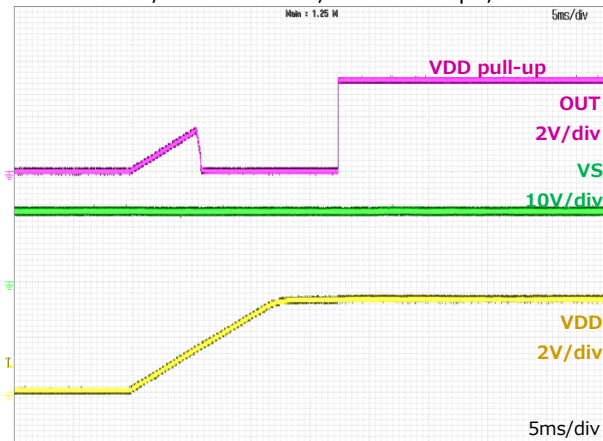

Waveform (VDD falling VS=13V)

VDD=3.3→0V, VS=13V, CCDH=9.1nF,
CCDL=9.1nF, RPULL=10kΩ, COU=220pF, Ta=25°C

