

IC for System Reset Monolithic IC PST93XX Series

August 3, 2000

Outline

This IC is a low-reset type system reset IC and in a variety of CPU systems and other logic systems, to detect supply voltage and reset the system accurately when the power is turned on or interrupted. It includes a high-precision voltage detection function with ultra-low current consumption and is ideal for voltage check circuits for products using a battery.

Features

- | | |
|--|---|
| 1. High-precision voltage detection | $V_S \pm 2\%$ max. |
| 2. Ultra-low current consumption | $I_{CCH} = 2.0\mu A$ typ. $I_{CCL} = 2.0\mu A$ typ. |
| 3. Low operating limit voltage | 0.65V typ. |
| 4. Hysteresis voltage provided for detection voltage | 50mV typ. |
| 5. Large output current during power-on | 5mA min. |
| 6. Detection voltage can be selected as desired within a range of 1.9V to 4.6V by 0.1V step, as indicated below. | |

PST93XX
 detection voltage value
 (Example: for 4.2V PST9342)

Package

SC-82ABA (PST93XXU)

Applications

1. Reset circuits for microcomputers, CPUs and MPUs
2. Reset circuits for logic circuits
3. Battery voltage check circuits
4. Back-up power supply switching circuits
5. Level detection circuits

Pin Assignment

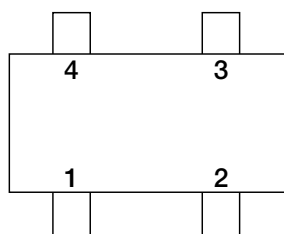

SC-82ABA
(TOP VIEW)

1	NC
2	GND
3	V_{OUT}
4	V_{CC}

Block Diagram

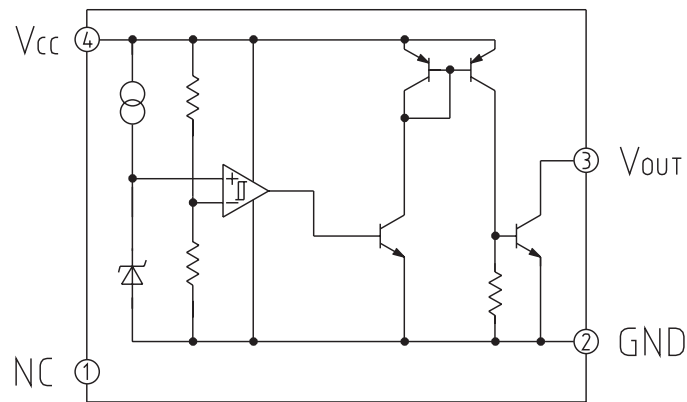

Pin Description

Pin no.	Pin name	Function
1	NC	
2	GND	GND pin
3	V _{OUT}	Reset signal output pin
4	V _{CC}	Power supply pin/voltage detection pin

Absolute Maximum Ratings (Ta=25°C)

Item	Symbol	Rating	Units
Storage temperature	T _{STG}	-40~+125	°C
Operating temperature	T _{OPR}	-20~+75	°C
Power supply voltage	V _{CC} max.	-0.3~+10	V
Allowable loss	P _d	150	mW

Recommended Operating Conditions

Item	Symbol	Rating	Units
Operating temperature	T _{OPR}	-20~+75	°C
Power supply voltage	V _{CC}	+0.85~+10	V

Electrical Characteristics (Ta=25°C)

Item	Symbol	Measurement circuit	Measurement conditions	Min.	Typ.	Max.	Units	
Detection voltage	Vs	1	V _{CC} =H→L R _L =4.7k V _{OL} ≤ 0.4V	PST9346	4.508	4.600	4.692	V
				PST9345	4.410	4.500	4.590	
				PST9344	4.312	4.400	4.488	
				PST9343	4.214	4.300	4.386	
				PST9342	4.116	4.200	4.284	
				PST9341	4.018	4.100	4.182	
				PST9340	3.920	4.000	4.080	
				PST9339	3.822	3.900	3.978	
				PST9338	3.724	3.800	3.876	
				PST9337	3.626	3.700	3.774	
				PST9336	3.528	3.600	3.672	
				PST9335	3.430	3.500	3.570	
				PST9334	3.332	3.400	3.468	
				PST9333	3.234	3.300	3.366	
				PST9332	3.136	3.200	3.264	
				PST9331	3.038	3.100	3.162	
				PST9330	2.940	3.000	3.060	
				PST9329	2.842	2.900	2.958	
				PST9328	2.744	2.800	2.856	
				PST9327	2.646	2.700	2.754	
PST9326	2.548	2.600	2.652					
PST9325	2.450	2.500	2.550					
PST9324	2.352	2.400	2.448					
PST9323	2.254	2.300	2.346					
PST9322	2.156	2.200	2.244					
PST9321	2.058	2.100	2.142					
PST9320	1.960	2.000	2.040					
PST9319	1.862	1.900	1.938					
Hysteresis voltage	ΔVs	1	V _{CC} =L →H→L, R _L =4.7k	30	50	100	mV	
Detection voltage temperature coefficient	Vs/ΔT	1	R _L =4.7k, Ta=-20~+75°C		±0.01		%/°C	
Low-level output voltage	V _{OL}	1	V _{CC} =Vs min.-0.05V, R _L =4.7k		0.1	0.4	V	
Output leakage current	I _{OH}	1	V _{CC} =V _O =10V			±0.1	μA	
Circuit current while on	I _{CC1}	1	V _{CC} =Vs min.-0.05V, R _L =∞		2.0	4.0	μA	
Circuit current while off	I _{CC2}	1	V _{CC} =Vs typ./0.85, R _L =∞		2.0	4.0	μA	
"H"transport delay time	t _{PLH}	2	R _L =4.7k, C _L =100pF *1		20	60	μs	
"L"transport delay time	t _{PHL}	2	R _L =4.7k, C _L =100pF *2		20	60	μs	
Operation limit voltage	V _{OPL}	1	R _L =4.7k, V _{OL} ≤ 0.4V		0.65	0.85	V	
Output current while on 1	I _{OL1}	1	V _{CC} =Vs min.-0.05V, V _O =0.4V	5			mA	
Output current while on 2	I _{OL2}	1	V _O =0.4V V _{CC} =Vs min.-0.05V, Ta=-20~+75°C	3			mA	

*1 : t_{PLH} : V_{CC}= (Vs typ.-0.4V)→(Vs typ.+0.4V)

*2 : t_{PHL} : V_{CC}= (Vs typ.+0.4V)→(Vs typ.-0.4V)

Measuring Circuit

(1)

S1=ON, S2=OFF : when measuring I_{OH} , I_{OL1} , I_{OL2}
 S1=OFF, S2=ON : for measuring other than the above

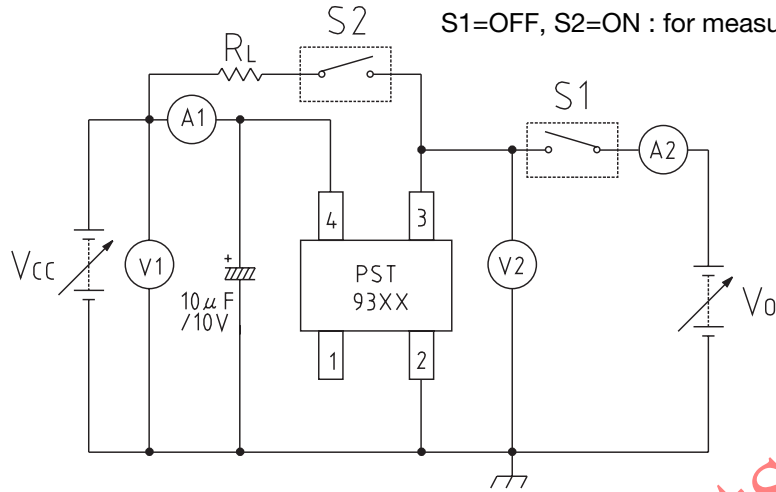

(2)

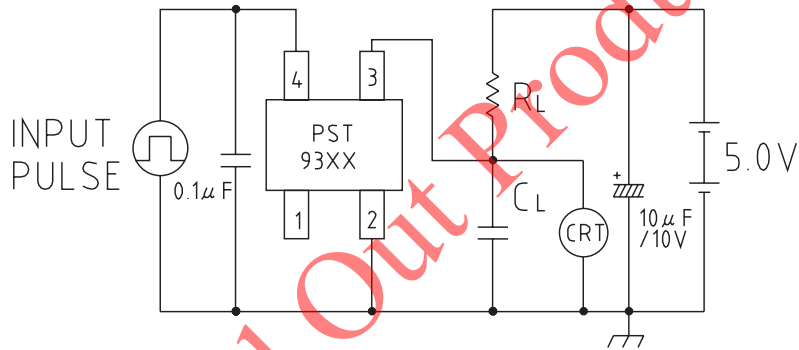

A : DC ammeter
 V : DC voltmeter
 CRT : Oscilloscope

INPUT PULSE

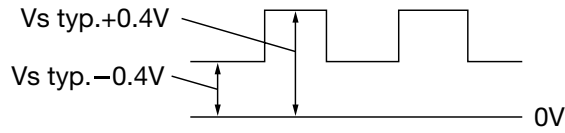

Application circuits

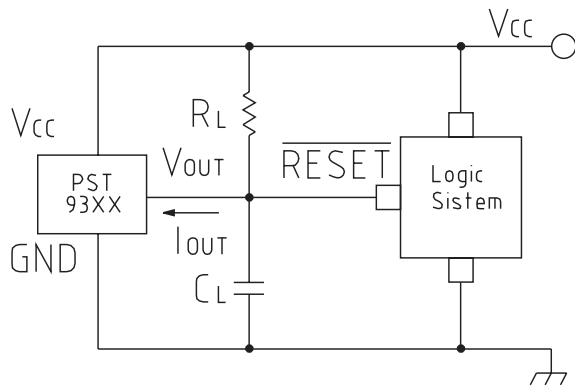

[CL setting]

Several tens of mV of oscillation may appear in V_{OUT} when V_{CC} is near operating limit (approx. 0.7V)~1.0V, if R_L is set at more than $R_L \cong 500k\Omega^*$ in the above application circuit. If this presents a problem, set the CL value slightly higher (1000pF or more recommended).

*: Varies slightly depending on V_S rank.

Characteristics

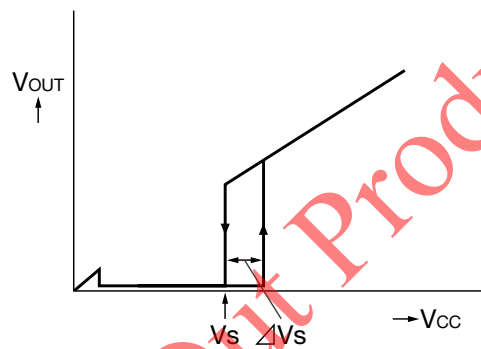

Phased Out Products