

3-Input 1-Output Video Switch (with Y-C mix) Monolithic IC MM1188

Outline

This is a 3-input, 1-output video switch IC for video signal switching. Of the 3 inputs, one has an input pin that supports S input, and there is a built-in mixing circuit.

Features

- 1. Built-in mixing circuit and input pin for S input
- 2. Built-in 6dB amp
- 3. Clamp function (IN1-Y, IN2, IN3)
- 4. Mute function
- 5. Current consumption 12.5mA typ.
- 6. Operating power supply voltage range 8~13V
- 7. Frequency response 10MHz
- 8. Crosstalk 70dB (at 4.43MHz)

Package

SIP-9B (MM1188XS)

Applications

- 1. TV
- 2. VCR, etc.

Block Diagram

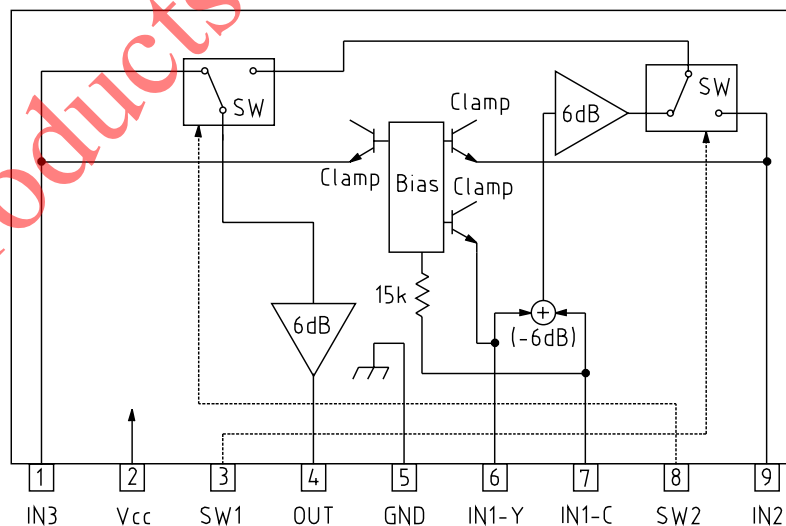

Control input truth table

SW1	SW2	OUT
L	L	IN1
H	L	IN2
-	H	IN3

Pin Description

Pin no.	Pin name	Function	Internal equivalent circuit diagram
1 9	IN3 IN2	Input 3 Input 2	
2	Vcc	Power supply	
3 8	SW1 SW2	Switch 1 Switch 2	
4	OUT	Output	
5	GND	Ground	
6	IN1-Y	Input 1 (luminance signal or composite signal)	

Products to be discontinued

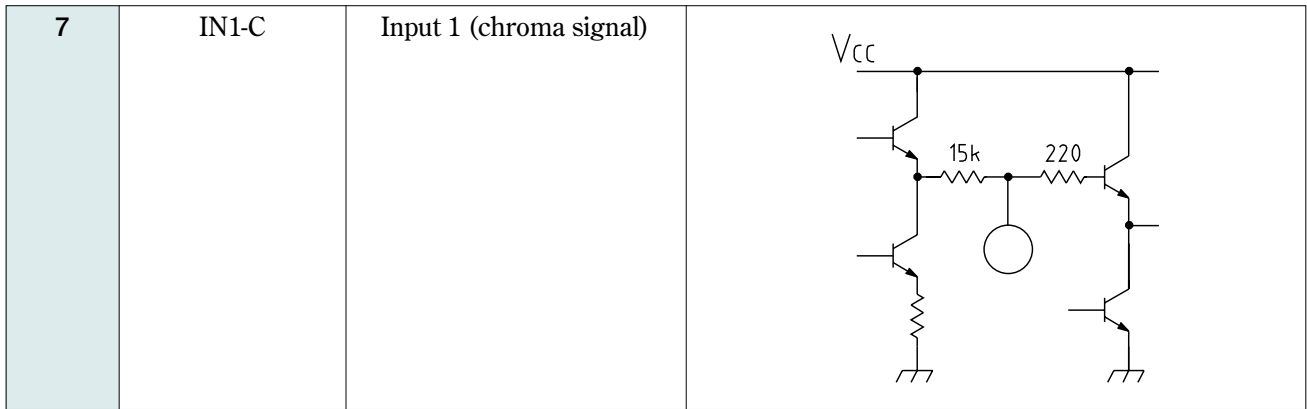

Absolute Maximum Ratings (Ta=25°C)

Item	Symbol	Ratings	Units
Storage temperature	T _{STG}	-40~+125	°C
Operating temperature	T _{OPR}	-20~+75	°C
Power supply voltage	V _{CC}	15	V
Allowable loss	P _d	1100	mW

Electrical Characteristics (Except where noted otherwise, Ta=25°C, V_{CC}=12.0V)

Item	Symbol	Measurement conditions	Min.	Typ.	Max.	Units
Operating power supply voltage range	V _{CC}		8.0		13.0	V
Consumption current	I _d	Refer to Measuring Circuit	8.8	12.5	16.5	mA
Voltage gain	G _v	Refer to Measuring Circuit	5.5	6.0	6.5	dB
Frequency characteristic	F _c	Refer to Measuring Circuit	-1	0	+1	dB
Differential gain	DG	Refer to Measuring Circuit		0	±3	%
Differential phase	DP	Refer to Measuring Circuit		0	±3	deg
Output offset voltage	V _{off}	Refer to Measuring Circuit			±60	mV
Crosstalk	C _T	Refer to Measuring Circuit		-70	-60	dB
Switch 1 input voltage H	V _{IH1}	Refer to Measuring Circuit	2.3			V
Switch 1 input voltage L	V _{IL1}	Refer to Measuring Circuit			0.9	V
Switch 2 input voltage H	V _{IH2}	Refer to Measuring Circuit	2.3			V
Switch 2 input voltage L	V _{IL2}	Refer to Measuring Circuit			0.9	V
IN1-C input dynamic range	A	DR _A	1.0			V _{P-P}
	B	DR _B	1.2			V _{P-P}
IN1-Y, IN2, IN3 input dynamic range	DR _C	Refer to Measuring Circuit	1.5			V _{P-P}
IN1-C input impedance	R _i			15		kΩ
IN1-C pin voltage	V _{I1C}	S1~S6=2	4.0	4.5	5.0	V
IN1-Y pin voltage	V _{I1Y}	S1~S6=2	4.1	4.6	5.1	V
IN2 pin voltage	V _{I2}	S1~S4=S6=2, S5=1	4.1	4.6	5.1	V
IN3 pin voltage	V _{I3}	S1~S5=2, S6=1	4.1	4.6	5.1	V
Out pin voltage	V _O	S1~S6=2	3.5	4.0	4.5	V

Measuring Procedures (Except where noted otherwise, $V_{CC}=12.0V$, $VC1=V_{CC}$, $VC2=0V$)

Item	Symbol	Switch state						Measuring Procedure	
		S1	S2	S3	S4	S5	S6		
Consumption current	Id	2	2	2	2	2	2	Connect a DC ammeter to the V_{CC} pin and measure. The ammeter is shorted for use in subsequent measurements.	
Voltage gain	Gv	1	2	2	2	2	2	Input a $1.0V_{P-P}$, 100kHz sine wave to SG, and obtain Gv from the following formula given TP1 voltage as V1 and TP3 voltage as V2. $Gv=20\text{LOG}(V2/V1)$ dB	
		2	1	2	2	2	2		
		2	2	1	2	1	2		
		2	2	2	1	1	1		
Frequency characteristic	Fc	1	2	2	2	2	2	For the above Gv measurement, given TP3 voltage for 10MHz as V3, Fc is obtained from the following formula. $Fc=20\text{LOG}(V3/V2)$ dB	
		2	1	2	2	2	2		
		2	2	1	2	1	2		
		2	2	2	1	1	1		
Differential gain	DG	2	1	2	2	2	2	Input a $1.0V_{P-P}$ staircase wave to SG, and measure differential gain at TP3. *1 $APL=10\sim 90\%$	
		2	2	1	2	1	2		
		2	2	2	1	1	1		
		2	2	2	1	2	1		
Differential phase	DP	2	1	2	2	2	2	Proceed as for DG, and measure differential phase. *2	
		2	2	1	2	1	2		
		2	2	2	1	1	1		
		2	2	2	1	2	1		
Output offset voltage	Voff	2	2	2	2	2	2	Measure the DC voltage difference of each switch status at TP2.	
		2	2	2	2	1	2		
		2	2	2	2	1	1		
Crosstalk	Cr	1	2	2	2	1	2	Assume $VC1=2.3V$, $VC2=0.9V$. Input a $1.0V_{P-P}$, 4.43MHz sine wave to SG, and given TP3 voltage during signal output as V4, switch S5 and S6, and given TP3 voltage for output OFF as V5, Cr is obtained from the following formula. $Cr=20\text{LOG}(V5/V4)$ dB	
		1	2	2	2	2	1		
		1	2	2	2	1	1		
		2	1	2	2	1	2		
		2	1	2	2	1	1		
		2	2	1	2	2	2		
		2	2	1	2	2	1		
		2	2	2	1	1	1		
2	2	2	1	1	2				
Switch 1 input voltage H	V _{IH1}	2	2	2	2	1	2	Impress an optional DC voltage on TP7 and TP8. Gradually raise from $VC1=0V$. TP4 voltage when TP8 voltage is output on TP2 is V _{IH1} . Gradually lower from $VC1=V_{CC}$. TP4 voltage when TP7 voltage is output on TP2 is V _{IL1} .	
Switch 1 input voltage L	V _{IL1}								
Switch 2 input voltage H	V _{IH2}	2	2	2	2	2	1	Impress an optional DC voltage on TP7 and TP9. Gradually raise from $VC1=0V$. TP5 voltage when TP9 voltage is output on TP2 is V _{IH2} . Gradually lower from $VC1=V_{CC}$. TP5 voltage when TP7 voltage is output on TP2 is V _{IL2} .	
Switch 2 input voltage L	V _{IL2}								
IN1-C input dynamic range	A	DR _A	3	1	2	2	2	2	Input a luminance signal as shown in Figure 1 to SG1, and a chroma signal as shown in Figure 2 to SG2. Change the chroma signal amplitude and measure the maximum amplitude where there is no waveform distortion at TP3 and convert to input amplitude.
	B	DR _B	3	1	2	2	2	2	
IN1-Y, IN2, IN3 input dynamic range	DR _C	2	1	2	2	2	2	Input a sine wave to SG1. Measure the maximum amplitude where there is no waveform distortion at TP3 and convert to input amplitude.	
		2	2	1	2	1	2		
		2	2	2	1	1	1		

Note : *1 *2 Measurement of IN1-C and IN1-Y mixed differential gain and differential phase is as follows.
 Switch status : S1=3, S2=1, S3=S4=S5=S6=2
 Measuring procedure : Input a 1.0V_{P-P} staircase wave signal (without chroma signal) to SG1, and a chroma signal to SG2. Measure TP3 differential gain and differential phase.

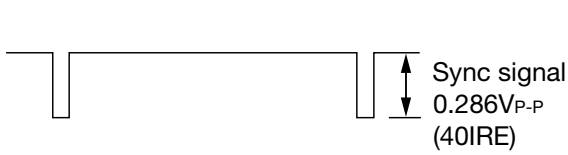

Figure 1

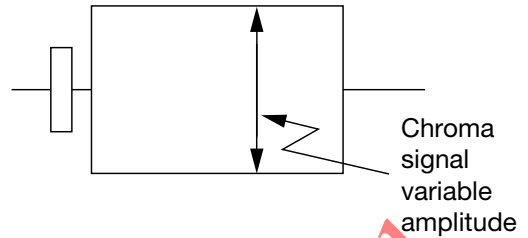

Figure 2

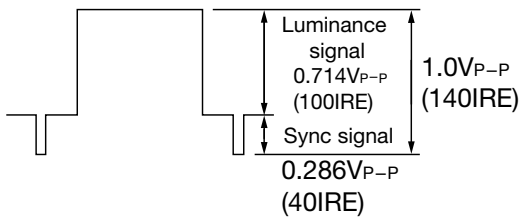

Figure 3

Measuring Circuit

