

Variable Gain Amplifier (built-in Y LPF, C BPF) Monolithic IC MM1304

December 6, 1994

Outline

This IC is a variable gain amp for video with built-in luminance low-pass filter and chroma band-pass filter. It was developed as a post-filter followed by a D/A converter.

The sampling frequencies for the D/A converter are assumed to be 14.3MHz for chroma, and 14.3MHz and 9.5MHz for luminance.

Features

1. Luminance LPF cutoff frequency can be selected and set at 5.4MHz and 4.4MHz. When set at 5.4MHz, use in models that support S, and in normal models when set at 4.4MHz.
2. Chroma BPF center frequency can be selected and set at 3.58MHz (NTSC) and 4.4MHz (PAL).
3. Luminance variable gain range $-6\sim+6\text{dB}$
Chroma variable gain range $-3\sim+9\text{dB}$ and $\sim 1\sim 13\text{dB}$
4. Operating supply voltage $4.5\sim 5.5\text{V}$
5. Luminance S/N (unweight) $10\text{kHz}\sim 4.2\text{MHz}: 47\text{dB typ.}$

Package

SSOP-16A (MM1304XJ)

Applications

1. VCRs with camera
2. Other video equipment

Equivalent Circuit Diagram

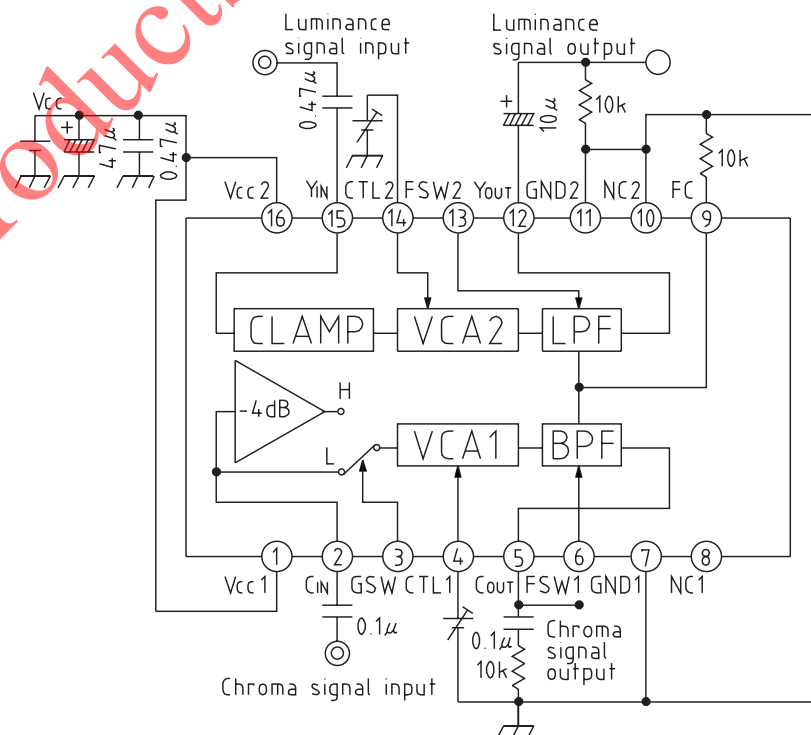

Pin Description

Pin no.	Pin name	Equivalent Circuit Diagram	Function
1	Vcc1		C power supply pin
2	CIN		Chroma signal input.
3	GSW		C gain switching pin. Set at 7dB standard for low, and 3dB standard for high.
4	CTL1		C gain control pin.
5	Cout		Chroma signal output pin.
6	FSW1		C BPF frequency switching pin. Set at 3.58MHz BPF for high, and 4.43MHz BPF for low.
7	GND1		C GND
8	NC1		NC pin

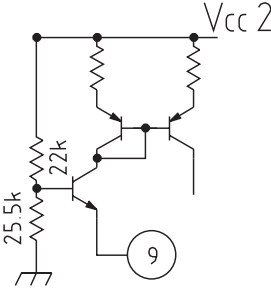
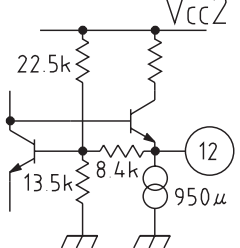
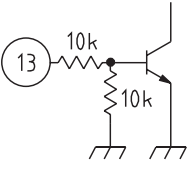
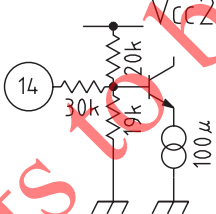
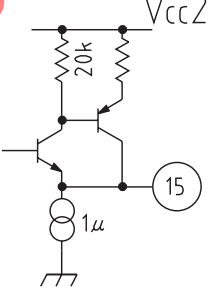
9	FC		Pin for adjusting LPF and BPF frequency response. Connect 10kΩ between this pin and ground.
10	NC2		NC pin
11	GND2		Y GND
12	Yout		Y output pin
13	FSW2		Y LPF frequency switching pin. Set at 4.4MHz LPF for high, and 5.4MHz LPF for low.
14	CTL2		Y gain control pin.
15	YIN		Luminance signal input pin.
16	Vcc2		Y power supply pin.

Products to be discontinued

Absolute Maximum Ratings (Ta=25°C)

Item	Symbol	Ratings	Units
Storage temperature	T _{STG}	-40~+125	°C
Operating temperature	T _{OPR}	-20~+75	°C
Power supply voltage	V _{CC max.}	8	V
Allowable loss	P _d	500	mW

Electrical Characteristics (Ta=25°C, Vcc=4.75V, V1=2.2V, V2=2.1V, SG1~SG2 : no signal, SW1~SW5 : A)

Item	Symbol	Measurement circuit	Measurement conditions	Min.	Typ.	Max.	Units
Operating power supply voltage	V _{CC}			4.5	4.75	5.5	V
Consumption current	I _{CC}				10.6	13	mA
Y subsystem cutoff frequency 5.4 MHz							
Voltage gain 1	G _{v1}	TP7	SG2 : sine wave 2V _{P-P} 100kHz V2=1.0V	-7.5	-6	-4.5	dB
Voltage gain 2	G _{v2}	TP7	SG2 : sine wave 1V _{P-P} 100kHz	-1.5	0	-1.5	dB
Voltage gain 3	G _{v3}	TP7	SG2 : sine wave 0.5V _{P-P} 100kHz V2=4.2V	4.5	6	7.5	dB
Cutoff frequency 5.4 MHz	fc1	TP7	SG2 : sine wave 1V _{P-P}	5			MHz
Frequency characteristic 1	G _{f1}	TP7	SG2 : sine wave 1V _{P-P} 14.5MHz			-30	dB
Group delay characteristic 1	td1	TP7	SG2 : sine wave 1V _{P-P} 100kHz	85	105	125	ns
Group delay characteristic 2	td2	TP7	SG2 : sine wave 1V _{P-P} 1MHz	90	110	130	ns
S/N	S _N	TP7	SG2 : white 50% video signal		-47	-43	dB
Y subsystem cutoff frequency 4.4 MHz SW5 : B							
Cutoff frequency 5.4 MHz	fc2	TP7	SG2 : sine wave 1V _{P-P}	4			MHz
Frequency characteristic 2	G _{f1}	TP7	SG2 : sine wave 1V _{P-P} 9.5MHz			-25	dB
Group delay characteristic 3	td3	TP7	SG1 : sine wave 1V _{P-P} 100kHz	105	125	145	ns
Group delay characteristic 4	td4	TP7	SG2 : sine wave 1V _{P-P} 1MHz	110	130	150	ns
C system NTSC Except where noted otherwise, SW4 : B							
Voltage gain 4	G _{v4}	TP4	SG1 : sine wave 0.14V _{P-P} V1=4.4V	9	13	15	dB
Voltage gain 5	G _{v5}	TP4	SG1 : sine wave 0.28V _{P-P}	3	7	9	dB
Voltage gain 6	G _{v6}	TP4	SG1 : sine wave 0.56V _{P-P} V1=1.1V	-3	1	3	dB
Voltage gain 7	G _{v7}	TP4	SG1 : sine wave 0.28V _{P-P} SW3 : B	-1	3	5	dB
Frequency characteristic 3	G _{f3}	TP4	SG1 : sine wave 0.28V _{P-P} 2.78MHz	-5.5	-3.5	+2	dB
Frequency characteristic 4	G _{f4}	TP4	SG1 : sine wave 0.28V _{P-P} 4.38MHz	-7.5	-3.5	+2	dB
Frequency characteristic 5	G _{f5}	TP4	SG1 : sine wave 0.28V _{P-P} 1.08MHz			-10	dB
Frequency characteristic 6	G _{f6}	TP4	SG1 : sine wave 0.28V _{P-P} 6.08MHz			-5	dB
Frequency characteristic 7	G _{f7}	TP4	SG1 : sine wave 0.28V _{P-P} 10MHz			-20	dB
Frequency characteristic 8	G _{f8}	TP4	SG1 : sine wave 0.28V _{P-P} 15MHz			-30	dB
Group delay characteristic 5	td5	TP4	SG1 : sine wave 0.28V _{P-P}	230	310	340	ns
Group delay characteristic 6	td6	TP4	SG1 : sine wave 0.28V _{P-P} 2.78MHz	160	240	320	ns
Group delay characteristic 7	td7	TP4	SG1 : sine wave 0.28V _{P-P} 4.38MHz	150	200	250	ns
C system PAL Except where noted otherwise, SG1 : f=4.43MHz							
Voltage gain 8	G _{v8}	TP4	SG1 : sine wave 0.28V _{P-P}	3	7	9	dB
Frequency characteristic 9	G _{f9}	TP4	SG1 : sine wave 0.28V _{P-P} 3.63MHz	-5.5	-2.2	+2	dB
Frequency characteristic 10	G _{f10}	TP4	SG1 : sine wave 0.28V _{P-P} 5.23MHz	-7.5	-3.0	+2	dB
Frequency characteristic 11	G _{f11}	TP4	SG1 : sine wave 0.28V _{P-P} 1.93MHz			-10	dB
Frequency characteristic 12	G _{f12}	TP4	SG1 : sine wave 0.28V _{P-P} 6.93MHz			-5	dB
Frequency characteristic 13	G _{f13}	TP4	SG1 : sine wave 0.28V _{P-P} 10MHz			-15	dB
Frequency characteristic 14	G _{f14}	TP4	SG1 : sine wave 0.28V _{P-P} 15MHz			-30	dB
Group delay characteristic 8	td8	TP4	SG1 : sine wave 0.28V _{P-P}	180	260	290	ns
Group delay characteristic 9	td9	TP4	SG1 : sine wave 0.28V _{P-P} 3.63MHz	120	200	280	ns
Group delay characteristic 10	td10	TP4	SG1 : sine wave 0.28V _{P-P} 5.23MHz	130	200	250	ns
Crosstalk							
Y → C	C _{T1}	TP4	SG2 : sine wave 1V _{P-P} 4.43MHz SW1 : B		-55	-50	dB
C → Y	C _{T2}	TP7	SG1 : sine wave 0.28V _{P-P} 4.43MHz SW2 : B		-55	-50	dB
SW input voltage SW3~SW5 : C							
GSW (H)	V _{IH1}	TP4	SG1 : sine wave 0.28V _{P-P} 4.43MHz	2.1			V
GSW (L)	V _{IL1}	TP4	SG1 : sine wave 0.28V _{P-P} 4.43MHz			0.7	V
FSW1 (H)	V _{IH2}	TP4	SG1 : sine wave 0.28V _{P-P} 4.43MHz	2.1			V
FSW1 (L)	V _{IL2}	TP4	SG1 : sine wave 0.28V _{P-P} 4.43MHz			0.7	V
FSW2 (H)	V _{IH3}	TP7	SG2 : sine wave 1V _{P-P} 4.43MHz	2.1			V
FSW2 (L)	V _{IL3}	TP7	SG2 : sine wave 1V _{P-P} 4.43MHz			0.7	V

Measuring Circuit

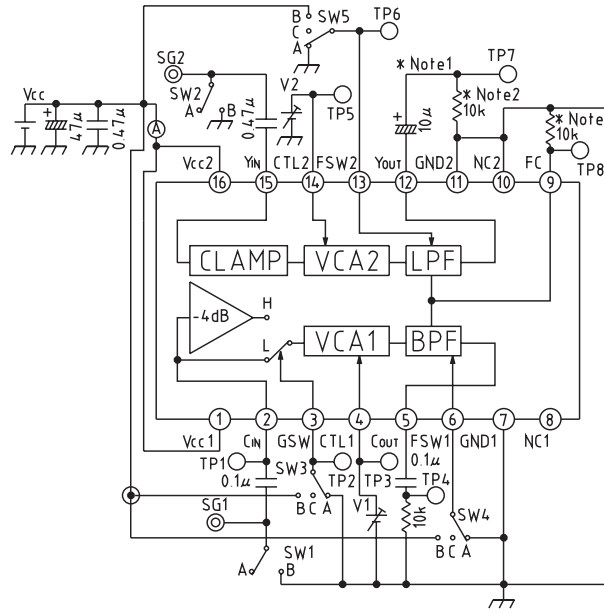

- *1 Design so that , to the extent possible, Y_{OUT} pin and FC pin are not capacitance coupled. Filter frequency response may be affected.
- *2 Connect NC2 pin to ground.
- *3 Use component with ±1% precision.

Characteristics (IC internal filters)

1. LPF

■ 5.4MHzLPF Amplitude-Frequency response

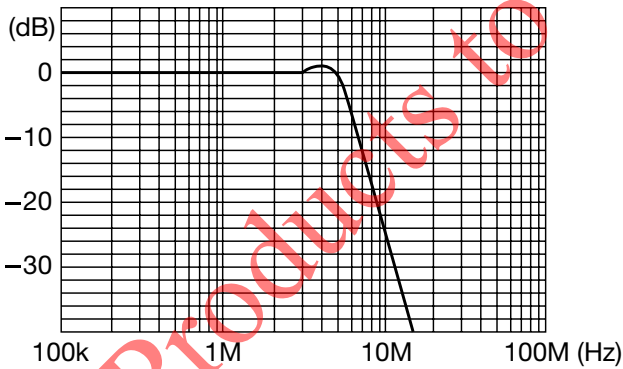

■ 4.4MHzLPF Amplitude-Frequency response

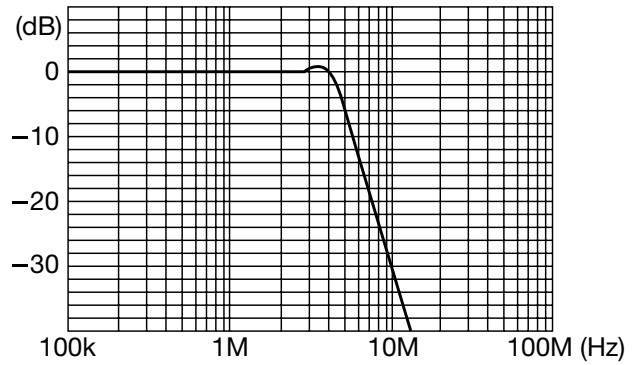

2. BPF

■ 3.58MHzBPF Amplitude-Frequency response

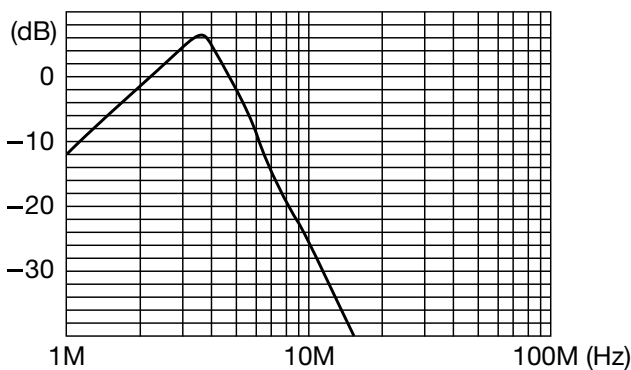

■ 4.43MHzBPF Amplitude-Frequency response

