

Pedestal Clamp 2-Input 1-Output 3-Circuit Video Switch Monolithic IC MM1389

April 1, 1997

Outline

This IC is a video switch IC developed for video cameras incorporating three 2-input 1-output video switch circuit. It is ideal for RGB and video signal switching as the inputs include a pedestal clamp function.

Features

- 1. Pedestal clamp input
- 2. Low current consumption 12mA typ. (V_{cc} 5V)
- 3. Frequency response 10MHz typ. 0dB
- 4. Operating supply voltage 4.5~12V

Package

SOP-16B (MM1389XF)

Applications

- 1. TV
- 2. VCR
- 3. Other video equipment

Block Diagram

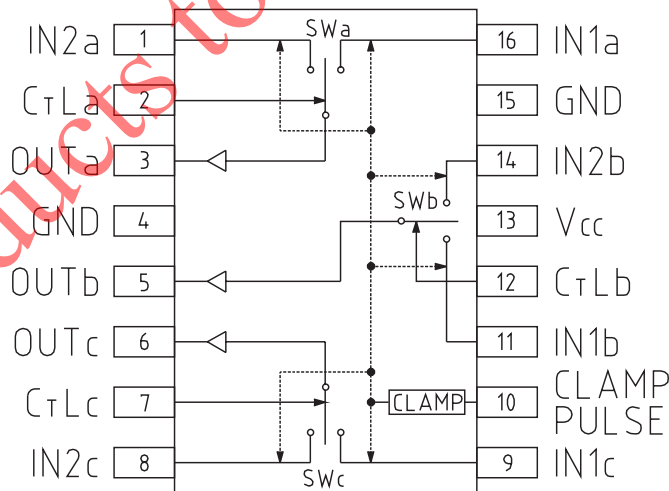

Control input truth table

SW	OUT
L	IN2a
	IN2b
	IN2c
H	IN1a
	IN1b
	IN1c

Pin Description

Pin no.	Pin name	Function	Internal equivalent circuit diagram
1 8 9 11 14 16	IN2a IN2c IN1c IN1b IN2b IN1a	Input pin 2SWa Input pin 2SWc Input pin 1SWc Input pin 1SWb Input pin 2SWb Input pin 1SWa	
2 7 12	CτLa CτLb CτLc	Switching pin a Switching pin b Switching pin c	
3 5 6	OUTa OUTb OUTc	Output pin SWa Output pin SWb Output pin SWc	
4 15	GND GND	GND pin 1 GND pin 2	
10	CLAMP PULSE	Clamp pulse input pin	
13	Vcc	Power supply voltage pin	

Absolute Maximum Ratings (Ta=25°C)

Item	Symbol	Ratings	Units
Storage temperature	T _{STG}	-40~+125	°C
Operating temperature	T _{OPR}	-25~+75	°C
Power supply voltage	V _{CC max.}	15	V
Allowable loss	P _d	350	mW

Recommended Operating Conditions

Item	Symbol	Ratings	Units
Operating temperature	T _{OPR}	-25~+75	°C
Operating voltage	V _{OP}	4.5~12.0	V

Electrical Characteristics (Except where noted otherwise, Ta=25°C, V_{CC}=5.0V)

Item	Symbol	Measurement conditions	Min.	Typ.	Max.	Units
Consumption current	I _D	Refer to Measuring Circuit		12.0	17.0	mA
Voltage gain	G _V	Refer to Measuring Circuit	-0.5	0	+0.5	dB
Frequency characteristic	F _C	Refer to Measuring Circuit	-1	0	+1	dB
Dynamic range 1	V _{D1}	Refer to Measuring Circuit	1.40	1.65		V _{P-P}
Dynamic range 2	V _{D2}	Refer to Measuring Circuit	0.80	0.95		V _{P-P}
Crosstalk	C _T	Refer to Measuring Circuit		-70	-60	dB
Switch input voltage H	V _{IH}	Refer to Measuring Circuit	2.1			V
Switch input voltage L	V _{IL}	Refer to Measuring Circuit			0.7	V
Clamp pin input voltage H	V _{CH}	Refer to Measuring Circuit	2.1			V
Clamp pin input voltage L	V _{CL}	Refer to Measuring Circuit			0.7	V

V_{D1} : Positive dynamic range (from clamp level)

V_{D2} : Negative dynamic range (from clamp level)

Measuring Procedures

(Except where noted otherwise, $V_{CC}=5.0V$, $V_{C1}=V_{CC}$, $V_{C2}=0V$, $PULSE=V_{CC}$, $C1\sim C6=0.1\mu F$, impress $V_B=3.5V$ when S9 is 2)

Item	Symbol	Switch state										Notes
		S1	S2	S3	S4	S5	S6	S7	S8	S9	S10~S15	
Consumption current	I_D	2	2	2	2	2	2	2	2	1	2	
Voltage gain	G_V	1	2	2	2	2	2	1	1	2	1	
		2	1	2	2	2	2	2	1	2	1	
		2	2	1	2	2	2	1	2	2	1	
		2	2	2	1	2	2	2	2	2	1	
		2	2	2	2	1	2	1	3	2	1	
		2	2	2	2	2	1	2	3	2	1	
Frequency characteristic	FC	1	2	2	2	2	2	1	1	2	1	
		2	1	2	2	2	2	2	1	2	1	
		2	2	1	2	2	2	1	2	2	1	
		2	2	2	1	2	2	2	2	2	1	
		2	2	2	2	1	2	1	3	2	1	
		2	2	2	2	2	1	2	3	2	1	
Dynamic range 1, 2	V_{D1}	1	2	2	2	2	2	1	1	1	2	VD1: Positive dynamic range (from clamp level)
		2	1	2	2	2	2	2	1	1	2	
	V_{D2}	2	2	2	1	2	2	2	2	1	2	VD2: Negative dynamic range (from clamp level)
		2	2	2	2	1	2	1	3	1	2	
		2	2	2	2	2	1	2	3	1	2	
Crosstalk	C_T	1	2	2	2	2	2	1	1	2	1	
		2	1	2	2	2	2	2	1	2	1	
		2	2	1	2	2	2	1	2	2	1	
		2	2	2	1	2	2	2	2	2	1	
		2	2	2	2	1	2	1	3	2	1	
		2	2	2	2	2	1	2	3	2	1	
Switch input voltage H, L	V_{IH}	1	2	2	2	2	2	1	1	2	1,2	
		2	2	1	2	2	2	1	2	2	1,2	
		2	2	2	2	1	2	1	3	2	1,2	
	V_{IL}	2	1	2	2	2	2	1	1	2	1,2	
		2	2	2	1	2	2	1	2	2	1,2	
		2	2	2	2	2	1	1	3	2	1,2	
Clamp pin input voltage H, L	V_{CTH} V_{CTL}	2	2	2	2	2	2	1	1	2	1	
		2	2	2	2	2	2	1	2	2	1	
		2	2	2	2	2	2	1	3	2	1	

(Except where noted otherwise, $V_{CC}=5.0V$, $V_{C1}=V_{CC}$, $V_{C2}=0V$, $PULSE=V_{CC}$, $C1\sim C6=0.1\mu F$, impress $V_B=3.5V$ when S9 is 2)

Item	Symbol	Measurement conditions	Notes
Consumption current	I_D	Connect a DC ammeter to the V_{CC} pin and measure. The ammeter is shorted for subsequent measurements.	
Voltage gain	G_V	Input a 2.0V _{P-P} , 100kHz sine wave to SG, and obtain G_V from the following formula given TP1 voltage as V_1 and TP3 voltage as V_2 . $G_V=20\text{Log} (V_2/V_1)$ dB	$f=100\text{kHz}$ $V=2.0V_{P-P}$
Frequency characteristic	F_C	For the above G_V measurement, given TP3 voltage for 10MHz as V_3 , F_C is obtained from the following formula. $F_C=20\text{Log} (V_3/V_2)$ dB	10MHz/100kHz $V=2.0V_{P-P}$
Dynamic range 1, 2	V_{D1} V_{D2}	Input a video signal to SG and a 5V _{P-P} clamp pulse to PULSE. Given input amplitude on the positive side of clamp level V_C as V_{D1IN} , and output amplitude as V_{D1OUT} and negative side input amplitude as V_{D2IN} , and output amplitude as V_{D2OUT} , V_{D2} is obtained from the following formula. $V_{D1} : 20\text{Log} (V_{D1OUT}/V_{D1IN}) \leq V_{D1IN}$ for -1dB $V_{D2} : 20\text{Log} (V_{D2OUT}/V_{D2IN}) \leq V_{D2IN}$ for -1dB	
Crosstalk	C_T	Input a 2.0V _{P-P} , 4.43MHz sine wave to SG, and given TP1 voltage as V_4 and TP3 voltage as V_5 , C_T is obtained from the following formula. $C_T=20\text{Log} (V_5/V_4)$ dB	$f=4.43\text{MHz}$ $V=2.0V_{P-P}$
Switch input voltage H, L	V_{IH} V_{IL}	Make S10, S12 and S14 1, and S11, S13 and S15 2. Input a 2.0V _{P-P} , 100kHz sine wave to SG, and raise gradually from $V_{C1}=0V$. TP4 voltage when the SG signal appears on TP2 is V_{IN} . Next, reverse S10~S15 settings and lower gradually from $V_{C1}=V_{CC}$. TP4 voltage when the SG signal appears on TP2 is V_{IL} .	
Clamp pin input voltage H, L	V_{CTH} V_{CTL}	Impress 4V on V_B and raise gradually from $PULSE=0V$. TP11 voltage when less than 2.0V appears on TP2 is V_{CTH} . Lower from $PULSE=V_{CC}$, and TP11 voltage when more than 2.2V appears on TP2 is V_{CTL} .	

Measuring Circuit

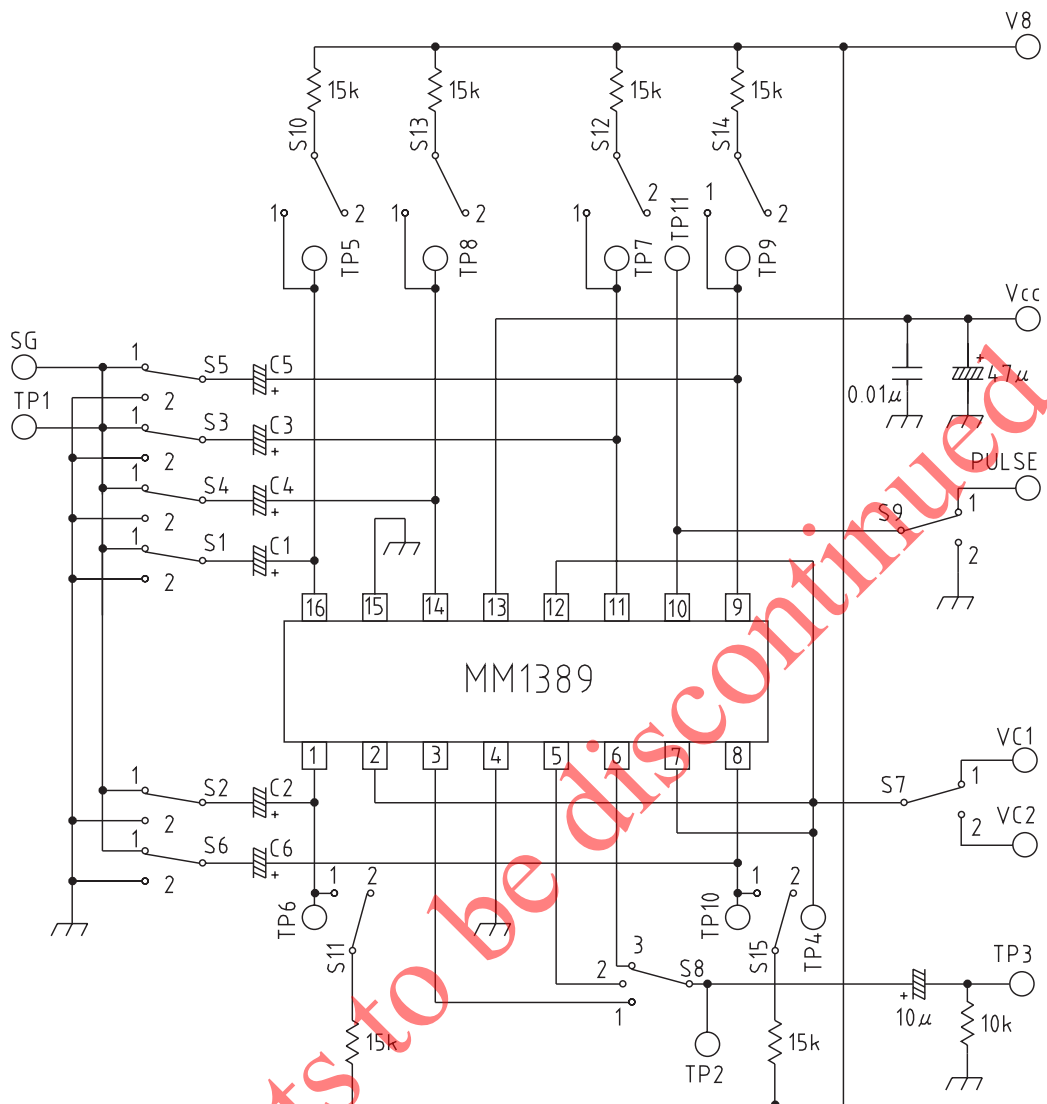

Products to be discontinued

