

Video Signal Driver for DVD Players

Monolithic IC MM1623/MM1758

October 8, 2001

Outline

This IC is a 6-ch video driver IC developed for DVD players and recorders. It includes a switching function for an LPF, which attenuates the DAC noise element, to support both progressive and interlace signals. The driver comprises a 2-channel 6dB amp with 75Ω driver.

In addition, external ESD protection diodes can be reduced by a DC superposition function (S1, S2 pins), and enhancement of the ESD protection elements for the output pins.

Features

1. Enables to driver a 2-channel 6dB amp with 75Ω driver
2. S/N=83dB typ.
3. Includes a 6dB amp
4. Includes a switching function for an LPF to support progressive and interlace signals
5. Includes a high-performance 4th-order LPF.
6. 6.75MHz/100kHz max. ±1.0dB 27MHz/100kHz typ. -40dB
7. ±15KV ESD for aerial discharge
8. Includes a DC superposition function in S1 and S2 pins
9. The component circuitry can support RGB signals with the control pin.

Package

SOP-28B

Pin Assignment

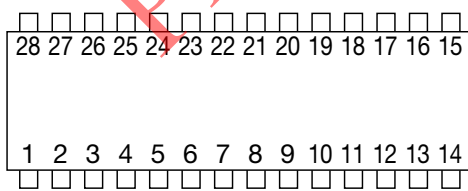

SOP-28B
(TOP VIEW)

1	Vcc1	15	GND2
2	C _{IN}	16	C _{ROUT}
3	MUTE1	17	GND2
4	CVBS _{IN}	18	C _{bOUT}
5	YC MIX.	19	GND2
6	Y _{IN}	20	CY _{OUT}
7	GND1	21	Y _{OUT}
8	BIAS	22	GND2
9	I/P	23	CVBS _{OUT}
10	CY _{IN}	24	S2
11	CLP	25	S1
12	C _{bIN}	26	C _{OUT}
13	MUTE2	27	S-DC _{OUT}
14	C _{IN}	28	Vcc2

Block Diagram

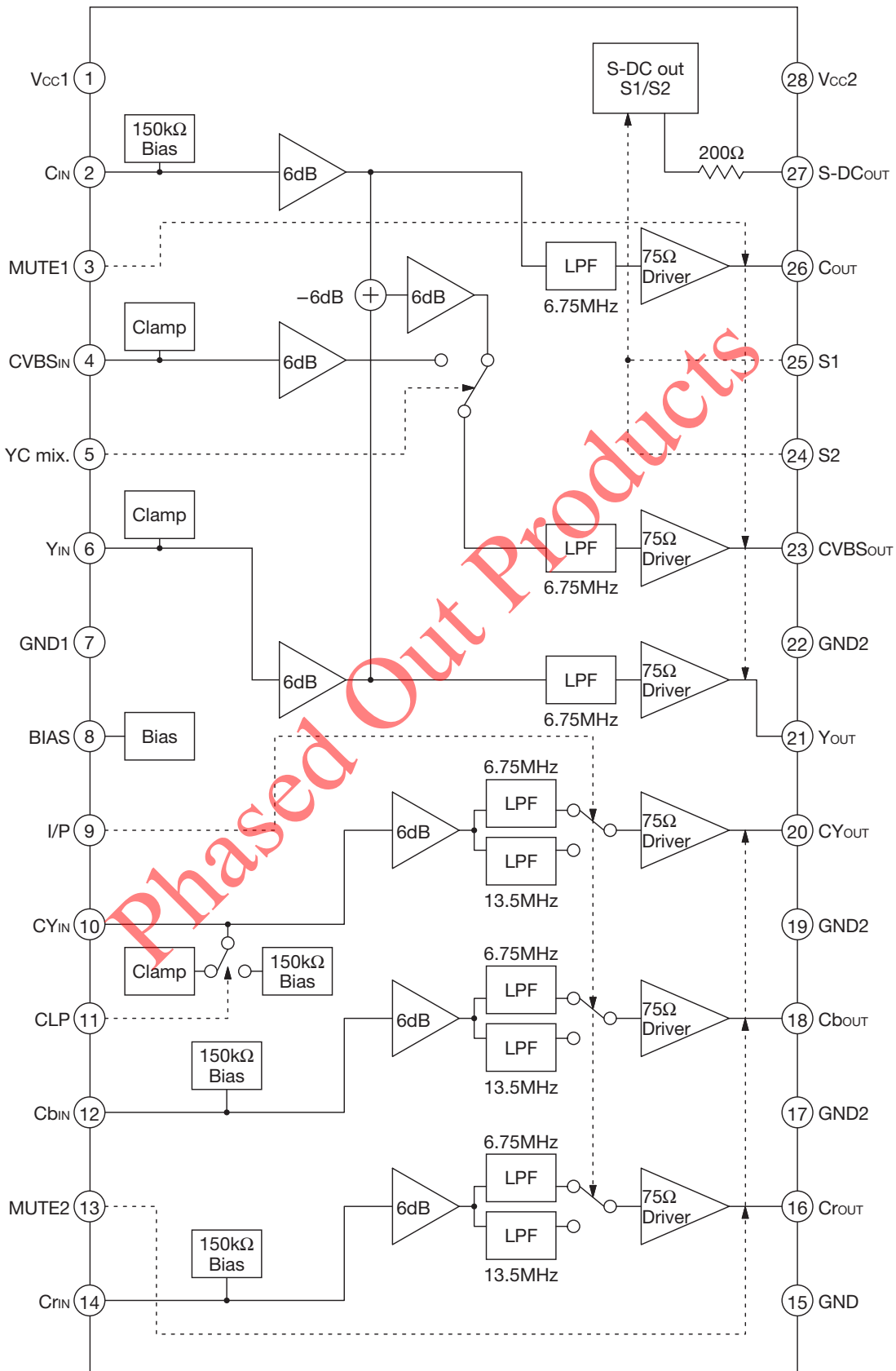

Pin Description

Pin no.	Pin name	Function	Internal equivalent circuit diagram
1 28	Vcc1 Vcc2	Vcc Vcc2 is power supply for 75Ω driver.	
2	CIN	Croma signal input	
3 13	MUTE1 MUTE2	Mute select Using of MUTE and POWER-SAVING.	
4 6	CVBSIN YIN	Video signal input (Composite video or Y) Sync tip clamp input	
5	YC mix.	YC MIX select	
7 15 17 19 22	GND1 GND2 GND2 GND2 GND2	GND GND2 is ground for 75Ω driver.	

Pin no.	Pin name	Function	Internal equivalent circuit diagram
8	BIAS	Bias	
9	I/P	Interlace / Progressive select	
10	CY _{IN}	Luminance input The input can select Sync tip clamp or Bias. Input signal : Y or G	
11	CLP	Input clamp select	
12 14	Cb _{IN} Cr _{IN}	Component input Input signal : Cb or B Cr or R	

Pin no.	Pin name	Function	Internal equivalent circuit diagram
16 18 20 21 23 26	C _{OUT} Cb _{OUT} CY _{OUT} Y _{OUT} CVBS _{OUT} C _{OUT}	Signal output	
24 25	S1 S2	S1/S2 select	
27	S-DC _{OUT}	S1/S2 DC output	

Phased Out Products

Absolute Maximum Ratings (Ta=25°C)

Item	Symbol	Ratings	Units
Storage temperature	T _{STG}	-65~+150	°C
Operating temperature	T _{OPR}	-40~+85	°C
Supply Voltage	V _{CC max.}	7	V
Allowable loss *	P _d	1.4	W

* Board mounting power dissipation. Board size 100 X100 X1.6mm

Recommended Operating Conditions

Item	Symbol	Ratings	Units
Operating temperature	T _{OPR}	-40~+85	°C
Operating voltage	V _{CCOP}	4.5~5.5	V

Electrical Characteristics (Except where noted otherwise, Ta=25°C, V_{CC}=5V)

Item	Symbol	Measurement conditions	Min.	Typ.	Max.	Units		
Supply current 1	I _{CC1}	No signal	77	110	143	mA		
Supply current 2	I _{CC2}	No signal, Mute1: ON	39	56	73	mA		
Supply current 3	I _{CC3}	No signal, Mute2: ON	39	56	73	mA		
Supply current 4	I _{CC4}	No signal, Mute1 and Mute2: ON	1	3	5	mA		
Croma input	V _{CIN}	2 PIN	1.9	2.4	2.9	V		
Composite video input	V _{CVBSIN}	4 PIN	0.9	1.1	1.3	V		
Luminance input	V _{YIN, CYIN}	6, 10 PIN	0.9	1.1	1.3	V		
Component input	V _{CBIN, CFIN}	12, 14 PIN	1.9	2.4	2.9	V		
Croma output	V _{COUT}	26 PIN		2.4		V		
Composite video output	V _{CVBSOUT}	23 PIN		1.1		V		
Luminance output	V _{YOUT, CYOUT}	21, 20 PIN		1.1		V		
Component output	V _{CbOUT, cCOUT}	18, 16 PIN		2.4		V		
Control terminal input current	H	I _{IHm} (*1)	3, 5, 9, 11, 13, 24, 25 PIN V _H =4.5V		350	μA		
	L	I _{ILm} (*1)	3, 5, 9, 11, 13, 24, 25 PIN V _L =0.4V		35	μA		
Control terminal input voltage	H	V _{thHm} (*1)	2.1			V		
	L	V _{thLm} (*1)			0.7	V		
S-DC out terminal output voltage	L	V _{DcOUTL}	R _L =10kΩ+100kΩ		0.1	0.5	V	
	M	V _{DcOUTM}	R _L =10kΩ+100kΩ		1.6	2.1	2.4	V
	H	V _{DcOUTH}	R _L =10kΩ+100kΩ		4.3	4.6	V	
Input impedance	Z _{CIN, cBIN, cFIN}	2, 12, 14 PIN	100	150	200	kΩ		
Output impedance	Z _{S-DCOUT}	27 PIN		200		Ω		
Voltage gain	G _{1n} (*2)	SIN wave: 1V, f=100kHz	5.7	6.0	6.3	dB		

Item	Symbol	Measurement conditions	Min.	Typ.	Max.	Units
Frequency characteristic 1 (C, CVBS, Y)	f ₁₋₅ (*2)	100 (IRE) SIN wave+40 (IRE) SYNC 6.75MHz/100kHz	-1.5	-0.5	0.5	dB
	f ₂₁₋₅ (*2)	100 (IRE) SIN wave+40 (IRE) SYNC 27MHz/100kHz		-33	-27	dB
Frequency characteristic 2 (CY, Cb, Cr) at Interlace select	f ₃₆₋₈ (*2)	100 (IRE) SIN wave+40 (IRE) SYNC 6.75MHz/100kHz	-0.5	0.5	1.5	dB
	f ₄₆₋₈ (*2)	100 (IRE) SIN wave+40 (IRE) SYNC 27MHz/100kHz		-28	-22	dB
Frequency characteristic 3 (CY, Cb, Cr) at Progressive select	f ₅₆₋₈ (*2)	100 (IRE) SIN wave+40 (IRE) SYNC 13.5MHz/100kHz	-1.5	-0.5	0.5	dB
	f ₆₆₋₈ (*2)	100 (IRE) SIN wave+40 (IRE) SYNC 54MHz/100kHz		-28	-22	dB
Differential gain	DG ₁₋₃ (*2)	Staircase signal 1V		1.0	1.5	%
Differential phase	DP ₁₋₃ (*2)	Staircase signal 1V		1.0	1.5	°
Output dynamic range	DR _{1,4,7,8} (*2)	SIN wave; 100kHz, THD=1.0%	2.6	3.0		V
	DR _{2,3,5,6} (*2)	SIN wave; 100kHz, THD=1.0%	2.6	2.8		V
Crosstalk	CT _n (*2)	f=4.43MHz, 1V		-60	-55	dB
S/N1	SN ₁₄₋₈ (*2)	BW: 100k~6MHz		-83		dB
S/N2	SN ₂₁₋₃ (*2)	BW: 100k~6MHz at mix. OUT		-77		dB
Group delay 1	t _{1GD1-5} (*2)	at 100kHz		40	80	ns
Group delay 2	t _{2GD6-8} (*2)	Interlace select at 100kHz		35	80	ns
Group delay 3	t _{3GD6-8} (*2)	Progressive select at 100kHz		22	50	ns
Group delay deviation 1 (C, CVBS Y)	Δt _{1GD1-5} (*2)	to 3.58MHz		4	10	ns
		to 4.42MHz		6	10	ns
		to 6MHz		12	20	ns
Group delay deviation 2 (CY, Cb Cr) at Interlace select	Δt _{2GD6-8} (*2)	to 1MHz		1	10	ns
		to 4MHz		4	10	ns
		to 6MHz		10	20	ns
Group delay deviation 3 (CY, Cb Cr) at Progressive select	Δt _{3GD6-8} (*2)	to 2MHz		1	10	ns
		to 8MHz		4	10	ns
		to 12MHz		10	20	ns
Between channel Group delay deviation 1	Δt _{1chGD}	Between C and Y at 3.58MHz		1	10	ns
Between channel Group delay deviation 2	Δt _{2chGD}	Between CY and Cb (Cr) at 1MHz (Interlace)		1	10	ns
Between channel Group delay deviation 3	Δt _{3chGD}	Between CY and Cb (Cr) at 2MHz (Progressive)		1	10	ns

Note: *1 The subscript number "m" is the terminal of right table.

m	Terminal
1	MUTE1
2	MUTE2
3	YC mix.
4	I/P
5	CLP
6	S1
7	S2

Note: *2 The subscript number "n" is the combination of right table.

n	Input	Output
1	CIN	CVBSOUT
2	CVBSIN	
3	YIN	
4	CIN	COUT
5	YIN	YOUT
6	CYIN	CYOUT
7	CbIN	CbOUT
8	CrIN	CrOUT

Measuring Circuit

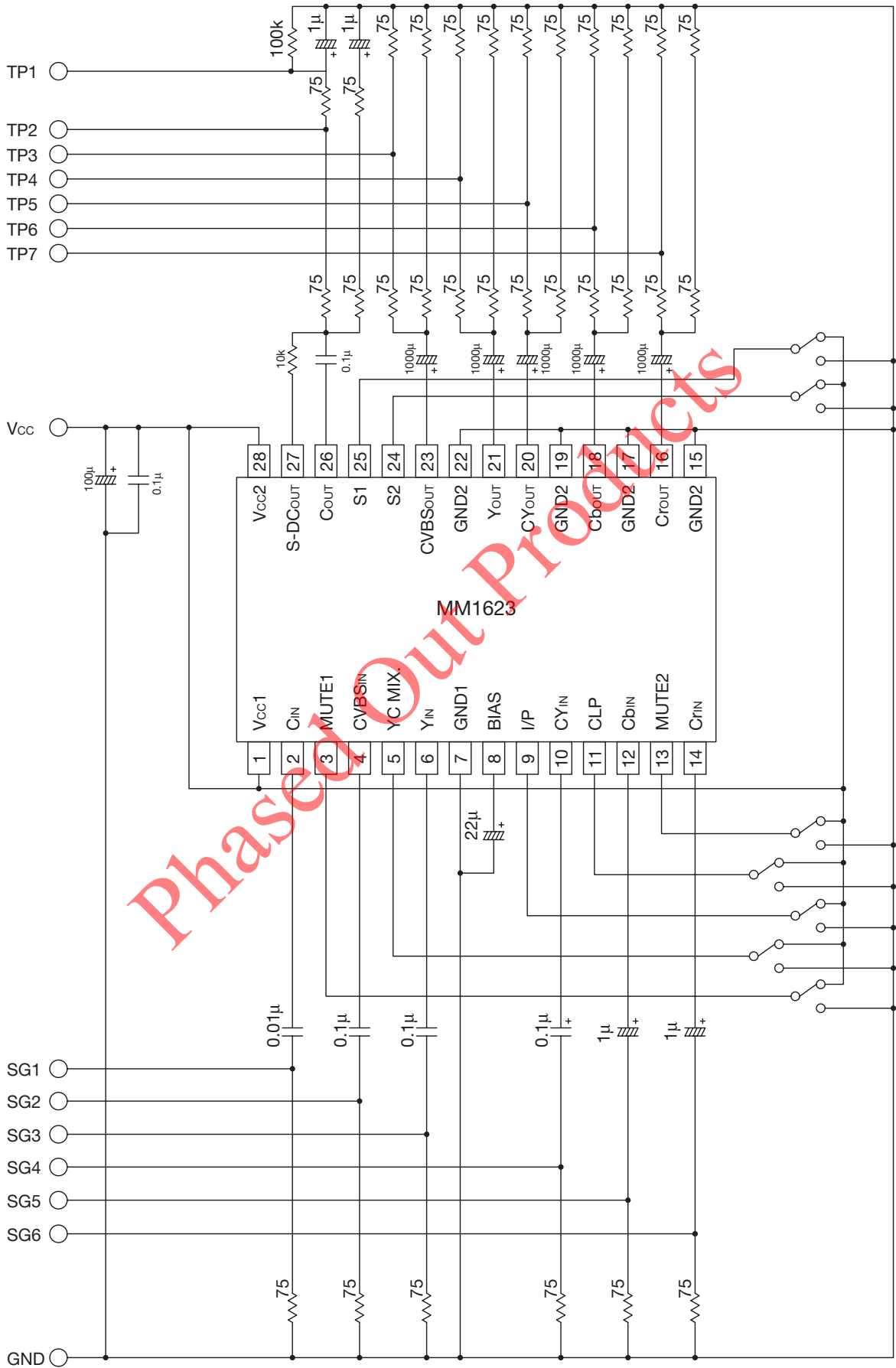

Switch Control Table

Input select	Output terminal	Control terminal			
		MUTE1	YC MIX.	MUTE2	CLP
MUTE	C _{OUT}	Low	*	*	*
C _{IN}		High	*	*	*
MUTE	CVBS _{OUT}	Low	*	*	*
Y _{IN} +C _{IN}		High	Low	*	*
CVBS _{IN}			High	*	*
MUTE	Y _{OUT}	Low	*	*	*
Y _{IN}		High	*	*	*
MUTE	CY _{OUT}	*	*	Low	*
CY _{IN} (CLAMP)		*	*	High	Low
CY _{IN} (Bias)		*	*		High
MUTE	Cb _{OUT}	*	*	Low	*
Cb _{IN}		*	*	High	*
MUTE	Cr _{OUT}	*	*	Low	*
Cr _{IN}		*	*	High	*

*: Don't care

Control terminal	Status	CY, Cb, Cr LPF Bandwidth
I/P	Low	13.5MHz (Progressive)
	High	6.75MHz (Interlace)

Control terminal		S-DC _{OUT} Output Voltage	Signal Mode
S1	S2		
Low	Low	0V	4:3 Normal
Low	High	2.1V	4:3 Letter box
High	High		
High	Low	4.6V	16:9 Squeeze

*: R_L=10kΩ+100kΩ

Application Circuit 1

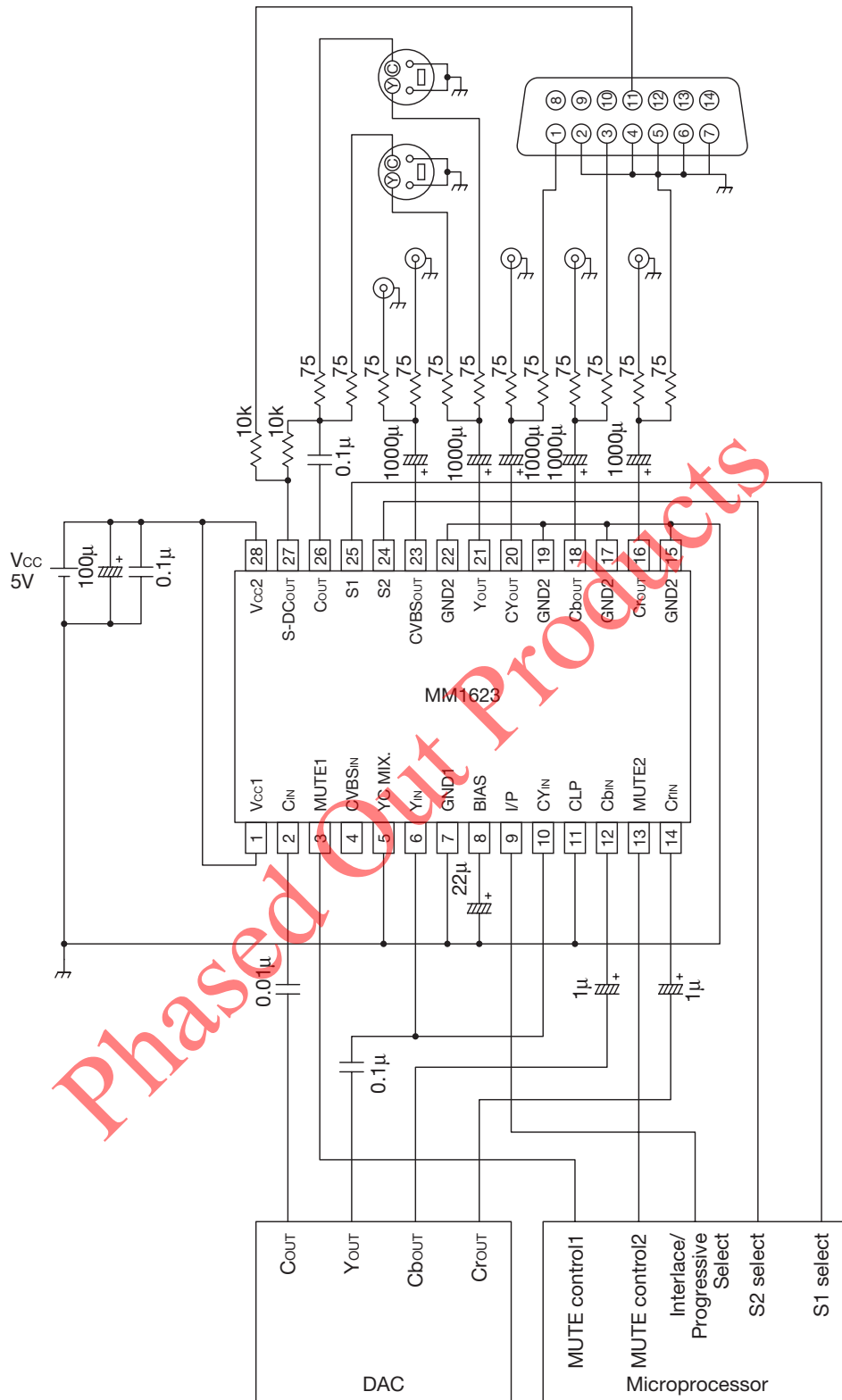

Note 1 Please arrange power supply bypass capacitor near the Vcc2 terminal (28pin).

Note 2 Please arrange the stray capacity component added to a signal output terminal to 20pF or less.

Application Circuit 2

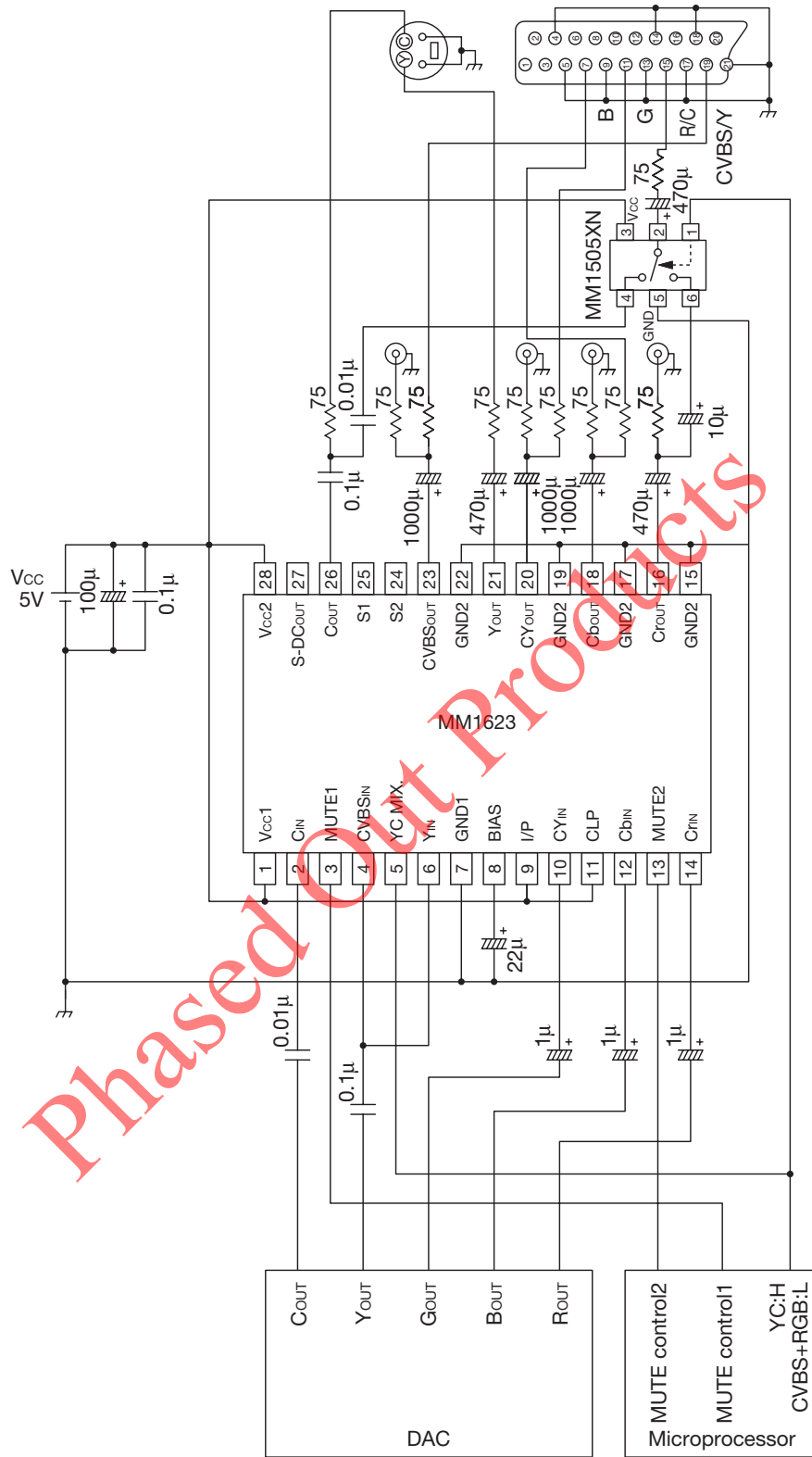

Note 1 Please arrange power supply bypass capacitor near the Vcc2 terminal (28pin).

Note 2 Please arrange the stray capacity component added to a signal output terminal to 20pF or less.

Characteristics

■ Frequency characteristic
(COUT, CVBSout, Yout)

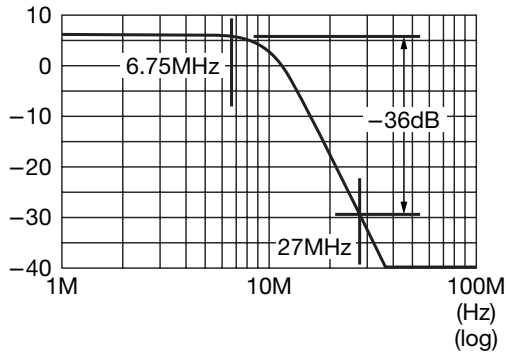

■ Group delay
(COUT, CVBSout, Yout)

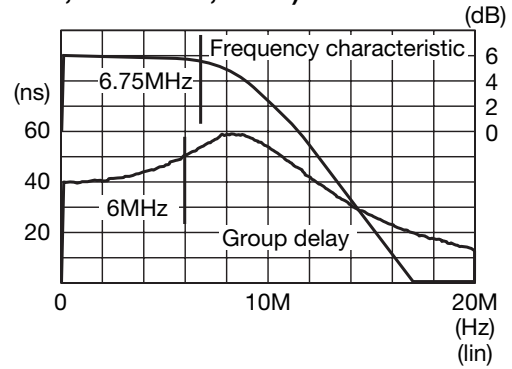

■ Frequency characteristic
(CYout, Cbout, CrouT) (at Interlace)

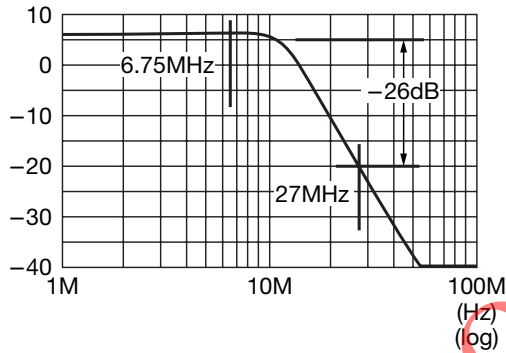

■ Group delay
(CYout, Cbout, CrouT) (at Interlace)

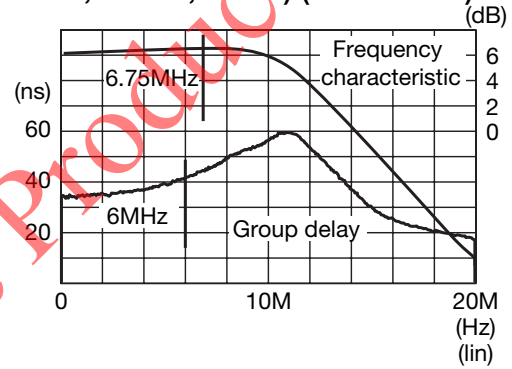

■ Frequency characteristic
(CYout, Cbout, CrouT) (at Progressive)

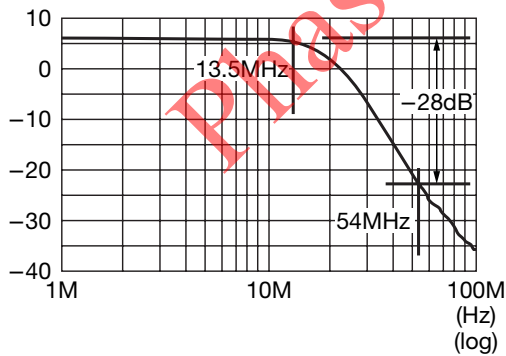

■ Group delay
(CYout, Cbout, CrouT) (at Progressive)

