

Wideband 2-Input 1-Output 3-Circuit Video Switch Monolithic IC MM1731~MM1734 Series

Outline

These ICs are video switch ICs incorporating three 2-input 1-output circuits and securing frequency pass bands required for HDTVs. The MM1731 series is developed by combination of the sync clamp input and bias input. These are ideal for switching wideband video signals and components signals such as HDTVs and STBs.

Line-up

Model name	Number of Input	Number of output	Clamp or Bias			Amplifier gain	75Ω driver
			SW1	SW2	SW3		
MM1731	2	1	bias	bias	bias	0dB	×
MM1732			bias	bias	clamp		
MM1733			bias	clamp	clamp		
MM1734			clamp	clamp	clamp		

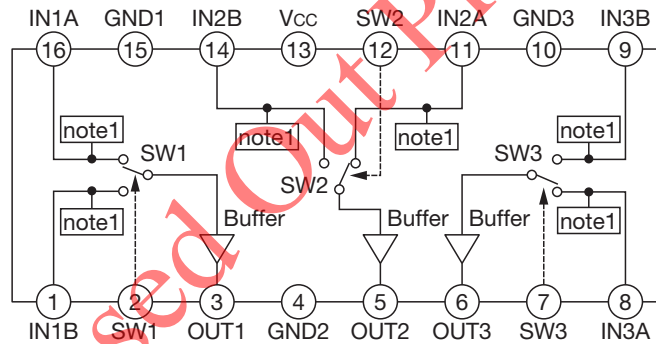

MM1731~MM1734
(note1: Clamp or Bias)

Block Diagram

MM1731

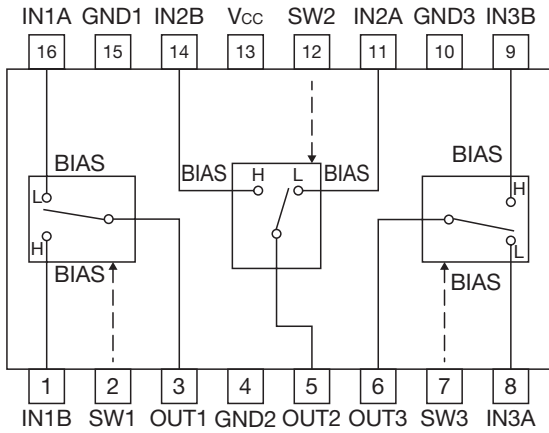

Control input truth table

SW	OUT
L	IN1A
	IN2A
	IN3A
H	IN1B
	IN2B
	IN3B

MM1732

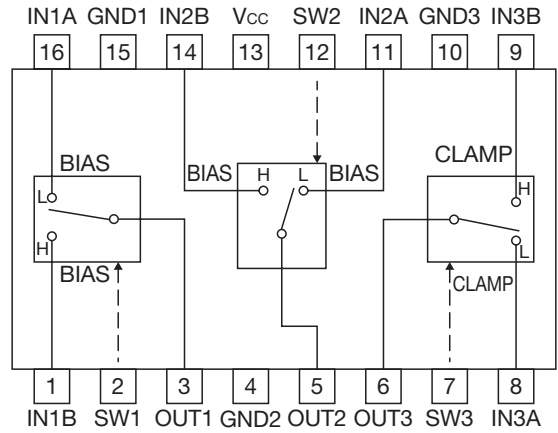

Control input truth table

SW	OUT
L	IN1A
	IN2A
	IN3A
H	IN1B
	IN2B
	IN3B

MM1733

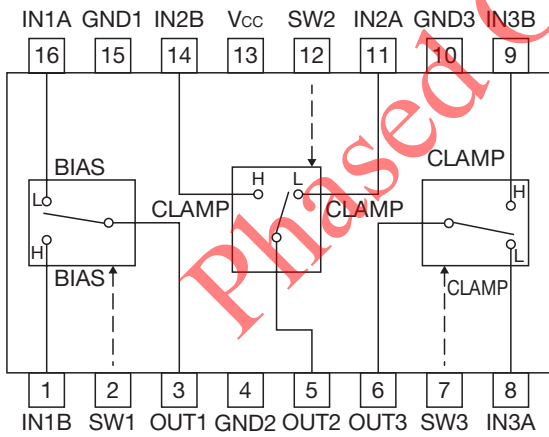

Control input truth table

SW	OUT
L	IN1A
	IN2A
	IN3A
H	IN1B
	IN2B
	IN3B

MM1734

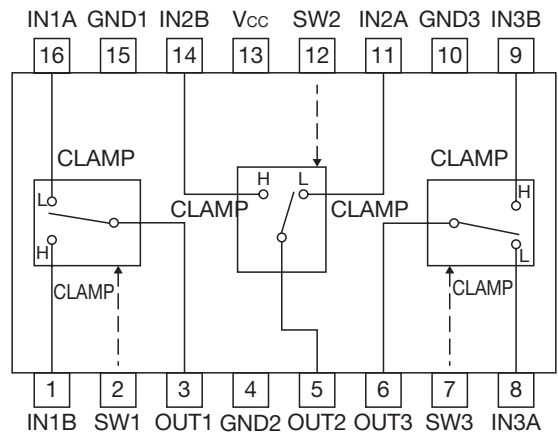

Control input truth table

SW	OUT
L	IN1A
	IN2A
	IN3A
H	IN1B
	IN2B
	IN3B

Introduction of Main Model

Wideband 2-Input 1-Output 3-Circuit Video Switch Monolithic IC MM1731

Features

- 1. High-frequency characteristic $0\pm 1\text{dB}$ at 50MHz/100kHz $V_{CC} : 5\text{V}$, $0\pm 3\text{dB}$ at 100MHz/100kHz $V_{CC} : 9\text{V}$
- 2. Power voltage characteristic 4.5~9.5V
- 3. 0dB buffer output (R_L: Can drive up to 1k Ω)

Packages

SOP-16B, TSOP-16A

Applications

- 1. HDTV
- 2. Digital set top boxes
- 3. Blu-ray, HD DVD players

Pin Assignment

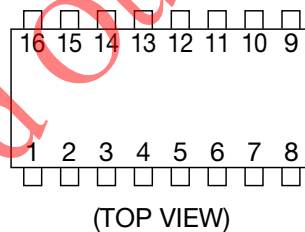

1	IN1B	5	OUT2	9	IN3B	13	V _{CC}
2	SW1	6	OUT3	10	GND3	14	IN2B
3	OUT1	7	SW3	11	IN2A	15	GND1
4	GND2	8	IN3A	12	SW2	16	IN1A

Pin Description

Pin no.	Pin name	Function	Equivalent circuit diagram
2 12 7	SW1 SW2 SW3	Switch	
3 5 6	OUT1 OUT2 OUT3	Output	
13	Vcc	Power Supply	
16 1 11 14 8 9	IN1A IN1B IN2A IN2B IN3A IN3B	Input	
15 4 10	GND	GND	

Absolute Maximum Ratings (Ta=5°C)

Item	Symbol	Ratings	Units
Storage temperature	T _{STG}	-40~+125	°C
Operating temperature	T _{OPR}	-30~+85	°C
Supply voltage	V _{CC}	10	V
Allowable loss	Single device	P _{d1}	350
	Board mounting (note1)	P _{d2}	470

note1 : Board size 70mm × 70mm × 1.6mm

Recommended Operating Conditions

Item	Symbol	Ratings	Units
Supply voltage	V _{CC}	4.5~9.5	V

Electrical Characteristics (Except where noted otherwise Ta=25°C, V_{CC}=5V)

Item	Symbol	Measurement conditions	Min.	Typ.	Max.	Units
Supply current	I _{CC}	Refer to Measuring Procedures		10	15	mA
Input terminal voltage	V _{IN}	No signal , No load	2.2	2.7	3.2	V
Output terminal voltage	V _{OUT}	No signal , No load		2.0		V
Voltage gain	G _v	SIN wave : 1MHz Refer to Measuring Procedures	-0.3	0	+0.3	dB
Frequency characteristic	f _c	SIN wave : 50MHz/1MHz Refer to Measuring Procedures	-1	0	+1	dB
Differential gain	DG	Refer to Measuring Procedures		0.5	±1	%
Differential phase	DP	Refer to Measuring Procedures		0.5	±1	°
Total harmonic distortion	THD	Refer to Measuring Procedures		0.03	0.3	%
Output dynamic range	V _D	Refer to Measuring Procedures	2.8	3.0		V
Crosstalk 1	C _{T1}	Refer to Measuring Procedures		-70	-60	dB
Crosstalk 2	C _{T2}	Refer to Measuring Procedures		-40		dB
Switch input voltage H	V _{IH}	Refer to Measuring Procedures	2.1			V
Switch input voltage L	V _{IL}	Refer to Measuring Procedures			0.7	V
Switch input current H	I _{IH}				350	μA
Switch input current L	I _{IL}				1.0	μA
Input impedance	Z _i			150		kΩ
Output impedance	Z _o			10		Ω

Measuring Procedures (Except where noted otherwise Ta=25°C, Vcc=5V)

Item	Symbol	Switch state								Measuring Procedure	
		S1	S2	S3	S4	S5	S6	S7	S8		
Supply Current	Id	2	2	2	2	2	2	2	2	1	Measure it by connecting a DC ammeter to Vcc terminal. Short the ammeter during use.
Voltage Gain	Gv	1	2	2	2	2	2	2	2	1	Input a 2.0V (P-P), 1MHz sine wave to SG. Assume V1 be the TP1 voltage and V2 be the TP3 voltage, and Gv is obtained by the following equation. Gv=20LOG (V2/V1) [dB]
		2	1	2	2	2	2	2	1	1	
		2	2	1	2	2	2	2	2	2	
		2	2	2	1	2	2	1	1	2	
		2	2	2	2	2	1	2	2	3	
Frequency Characteristics	Fc	1	2	2	2	2	2	2	2	1	Input a 1.0V (P-P), 1MHz or 50MHz sine wave to SG. Assume V3 be the TP3 voltage at 1MHz and V4 be the TP3 voltage at 50MHz, and Gv is obtained by the following equation. Gv=20LOG (V4/V3) [dB]
		2	1	2	2	2	2	1	1	1	
		2	2	1	2	2	2	2	2	2	
		2	2	2	1	2	2	1	1	2	
		2	2	2	2	2	1	2	2	3	
Differential Gain	DG	1	2	2	2	2	2	2	2	1	Input a 2.0V (P-P) staircase signal to SG, and measure the differential gain at TP3. APL=10~90 [%]
		2	1	2	2	2	2	1	1	1	
		2	2	1	2	2	2	2	2	2	
		2	2	2	1	2	2	1	1	2	
		2	2	2	2	2	1	2	2	3	
Differential Phase	DP	1	2	2	2	2	2	2	2	1	Measure the differential phase in the same way as in DC. APL=10~90 [%]
		2	1	2	2	2	2	1	1	1	
		2	2	1	2	2	2	2	2	2	
		2	2	2	1	2	2	1	1	2	
		2	2	2	2	2	1	2	2	3	
Total Harmonic Distortion	THD	1	2	2	2	2	2	2	2	1	Input a 2.5V (P-P) 1kHz sine wave to SG, and measure it by connecting a distortion factor meter to TP3.
		2	1	2	2	2	2	1	1	1	
		2	2	1	2	2	2	2	2	2	
		2	2	2	1	2	2	1	1	2	
		2	2	2	2	2	1	2	2	3	
Output Dynamic Range	V _D	1	2	2	2	2	2	2	2	1	The sine wave of 100kHz is input to SG. V _D is defined as TP3 voltage. (at THD=1%)
		2	1	2	2	2	2	1	1	1	
		2	2	1	2	2	2	2	2	2	
		2	2	2	1	2	2	1	1	2	
		2	2	2	2	2	1	2	2	3	
		2	2	2	2	2	1	1	3		

Item	Symbol	Switch state								Measuring Procedure
		S1	S2	S3	S4	S5	S6	S7	S8	
Crosstalk	CT	1	2	2	2	2	2	1	1	The DC voltage of 2.1V is given to VC1, and the DC voltage of 0.7V is given to VC2. The sine wave of 2.0V (P-P), 4.43MHz (CT1), 50MHz (CT2) is input to SG. V5 is a voltage of TP3 when the signal is output to the terminal OUT by operating SW. V6 is a voltage of TP3 when the signal is not output to the terminal OUT by operating SW. Then CT is defined as following method. $CT = 20 \text{LOG} (V6/V5) \text{ [dB]}$
		2	1	2	2	2	2	2	1	
		2	2	1	2	2	2	1	2	
		2	2	2	1	2	2	2	2	
		2	2	2	2	1	2	1	3	
		2	2	2	2	2	1	2	3	
SW Input Voltage H	VIH	2	2	2	2	2	2	1	1	Apply an optional DC voltage to TP5, 7, 9 and TP6. 8. 10. Increase the voltage gradually from VC1=0V, and assume V _{HI} be the TP4 voltage when the TP6,8,10 voltage is output to TP2. Decrease the voltage gradually from VC1=V _{CC} , and assume V _{LI} be the TP4 voltage when the TP5, 7, 9 voltage is output to TP2.
		2	2	2	2	2	2	1	2	
		2	2	2	2	2	2	1	3	
SW Input Voltage L	VIL	2	2	2	2	2	2	1	1	
		2	2	2	2	2	2	1	2	
		2	2	2	2	2	2	1	3	

Measuring Circuit

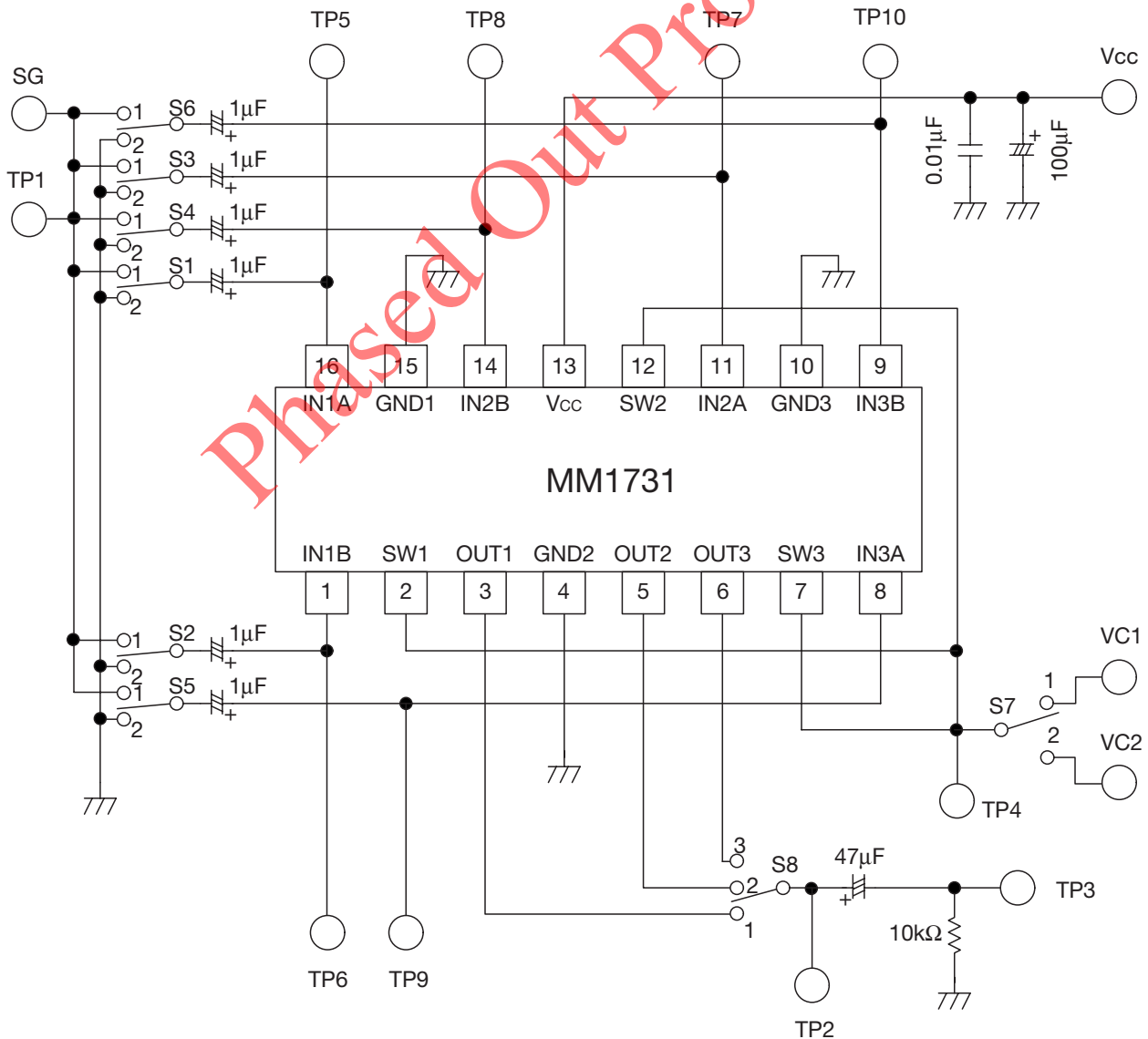

Characteristics (Except where noted otherwise IN 1A to Out1, $V_{CC}=5V$, $V_{IN}=1VP-P$)

■ Frequency Characteristics

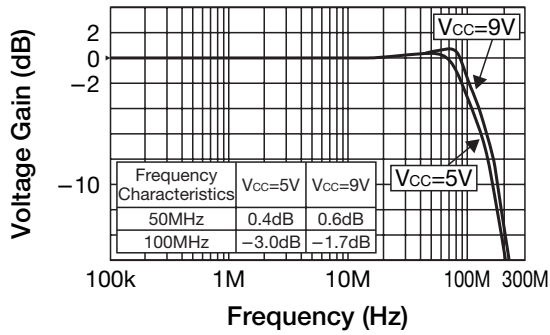

■ Group delay

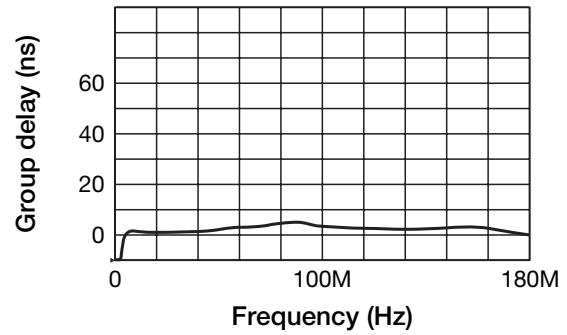

■ Differential gain

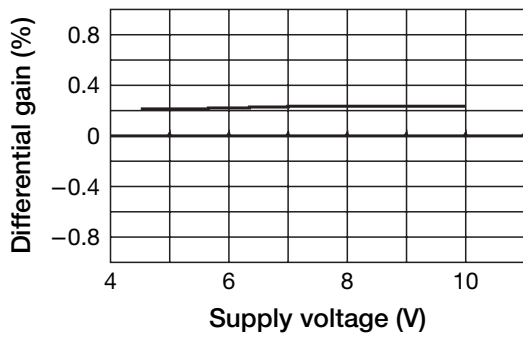

■ Differential phase

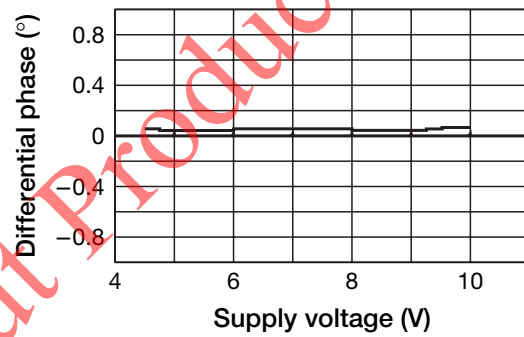

Phased Out Products