

4-Input Video Switch (without clamp) Monolithic IC MM1053

July 18, 2003

Outline

This IC is a 4-input 1-output video switch IC developed for TV, VCR and other video equipment.

Features

- | | |
|-----------------------------------|---------------------------|
| 1. Operating supply voltage range | $V_{CC}=4.75\sim 13V$ |
| 2. Frequency response | 0.1~10MHz ($\pm 1.0dB$) |

Package

SIP-9A

Applications

1. TV
2. VCR
3. Other video equipment

Block Diagram

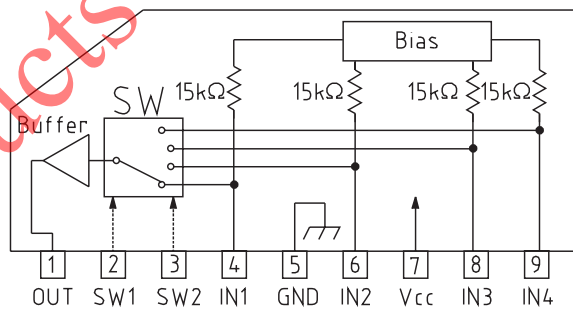

Control input truth table

OUT	IN1	IN2	IN3	IN4
SW1	H	L	H	L
SW2	H	H	L	L

Pin Description

Pin no.	Pin name	Function	Internal equivalent circuit diagram
1	OUT	Output	
2	SW1	Switch 1	
3	SW2	Switch 2	
4	IN1	Input 1	
5	GND	Ground	
6	IN2	Input 2	

Products to be discontinued

7	V _{CC}	Power supply	
8	IN3	Input 3	
9	IN4	Input 4	

Absolute Maximum Ratings (T_a=25°C)

Item	Symbol	Ratings	Units
Storage temperature	T _{STG}	-40~+125	°C
Operating temperature	T _{OPR}	-20~+75	°C
Power supply voltage	V _{CC}	15	V
Allowable loss	P _d	470	mW

Electrical Characteristics (Except where noted otherwise, Ta=25°C, Vcc=5.0V)

Item	Symbol	Measurement conditions	Measurement conditions	Min.	Typ.	Max.	Units
Operating power supply voltage range	V _{CC}	V _{CC}		4.75	5.0	13.0	V
Consumption current	I _d	V _{CC}			7.0	11.0	mA
Voltage gain	G _v	TP3	SG : Sine wave 2V _{P-P} , 0.1MHz *1	-0.5	0	0.5	dB
Frequency characteristic	F _c	TP3	SG : Sine wave 2V _{P-P} 10MHz/0.1MHz *1	-1	0	1	dB
Differential gain	DG	TP3	SG : Staircase wave 2V _{P-P} , APL=10, 50, 90%		0	3	%
Differential phase	DP	TP3	SG : Staircase wave 2V _{P-P} , APL=10, 50, 90%		0	3	deg
Output offset voltage	V _{off}	TP2				100	mV
Crosstalk	C _T	TP3	SG : Sine wave 2V _{P-P} , 4.43MHz *2		-65	-55	dB
Switching voltage 1	V _{TH1}	TP4	SG : Sine wave 2V _{P-P} , 0.1MHz *3	0.7	1.4	2.1	V
Switching voltage 2	V _{TH2}	TP5	SG : Sine wave 2V _{P-P} , 0.1MHz *3	0.7	1.4	2.1	V
Input impedance	R _i	TP3			15		kΩ
Output impedance	R _o	TP3			15		Ω

*1 Voltage gain G_v, frequency response F_c

If input at TP1 for 0.1MHz sine wave input is V₁, and output at TP3 is V₂, and output for 10MHz input is V₃, then :

$$G_v = 20 \text{LOG} \frac{V_2}{V_1}$$

$$F_c = 20 \text{LOG} \frac{V_3}{V_2}$$

*2 Crosstalk C_T

If input at TP1 for 4.43MHz sine wave input is V₄, and output at TP3 is V₅, then :

$$C_T = 20 \text{LOG} \frac{V_5}{V_4}$$

*3 Switching voltage V_{TH1}, V_{TH2}

TP4 level is V_{TH1} when TP4 DC level is changed by the external power supply and the output signal switches. TP5 level is V_{TH2} when TP5 DC level is changed by the external power supply and the output signal switches.

Switch Modes

Item	Symbol	Switch Mode					
		S1	S2	S3	S4	S5	S6
Consumption current	Id	2	2	2	2	3	3
Voltage gain	Gv	1	2	2	2	1	1
		2	1	2	2	3	1
		2	2	1	2	1	3
		2	2	2	1	3	3
Frequency gain	Fc	1	2	2	2	1	1
		2	1	2	2	3	1
		2	2	1	2	1	3
		2	2	2	1	3	3
Differential gain	DG	1	2	2	2	1	1
		2	1	2	2	3	1
		2	2	1	2	1	3
		2	2	2	1	3	3
Differential phase	DP	1	2	2	2	1	1
		2	1	2	2	3	1
		2	2	1	2	1	3
		2	2	2	1	3	3
Output offset voltage	Voff	2	2	2	2	1	1
		2	2	2	2	3	1
		2	2	2	2	1	3
		2	2	2	2	3	3
Crosstalk	Ct	2	1	2	2	1	1
		2	2	1	2	1	1
		2	2	2	1	1	1
		2	2	1	2	3	1
		2	2	2	1	3	1
		1	2	2	2	3	1
		2	2	2	1	1	3
		1	2	2	2	1	3
		2	1	2	2	1	3
		1	2	2	2	3	3
		2	1	2	2	3	3
		2	2	1	2	3	3
Switching voltage	V _{TH1}	1	2	2	2	2	1
	V _{TH2}	1	2	2	2	1	2

Measuring Circuit

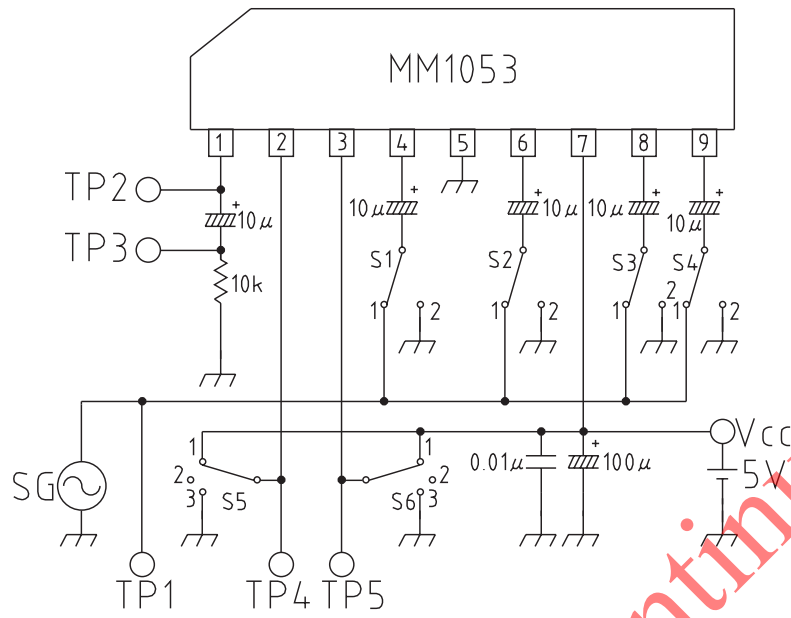

Products to be discontinued