

SPECIFICATIONS

Zener Barrier(Safety barrier)

(Recommended Practices for Explosion-Protected Electrical Installations in General Industries)

1. General

The instrument is a safety barrier applied with load cell for the purpose of application in intrinsically safe explosion-proofed measurement system in accordance with guidelines (Recommended Practices for Explosion-Protected Electrical Installations in General Industries) given by institute of Industrial Safety Ministry of labor. Moreover, this instrument has passed the test conducted by Industrial Safety Technique Association on characteristic required for intrinsically safe equipment.

2. Specifications

• P/No. Z964-TC20163

• Hazardous Area

Terminals 1 & 2 or Terminals 1 & 3

U _o =	12 V
I _o =	12.3 mA
P _o =	0.04 W
L _o =	235 mH
C _o =	1.41 μF

Terminals 2 & 4 or Terminals 3 & 4

U _o =	12 V
I _o =	12.3 mA
P _o =	0.04 W
L _o =	235 mH
C _o =	1.41 μF

Terminals 1, 4 & 2 or Terminals 4 & 3

U _o =	12 V
I _o =	24.5 mA
P _o =	0.08 W
L _o =	59.2 mH
C _o =	1.41 μF

Terminals 1 & 4

U _o =	24 V
I _o =	12.3 mA
P _o =	0.08 W
L _o =	235 mH
C _o =	0.125 μF

• Non-Hazardous Area

U_m= AC250 V 50/60 Hz, DC250 V

• Ambient Temperature -20 °C to 60 °C

• Weight Approx. 142 g

SPECIFICATIONS

Z964-TC20163

Spec. No. EN3538913-B

2/4

3. Option (Socket)

- P/No. ZH-Z. ES

4. Outline dimensions

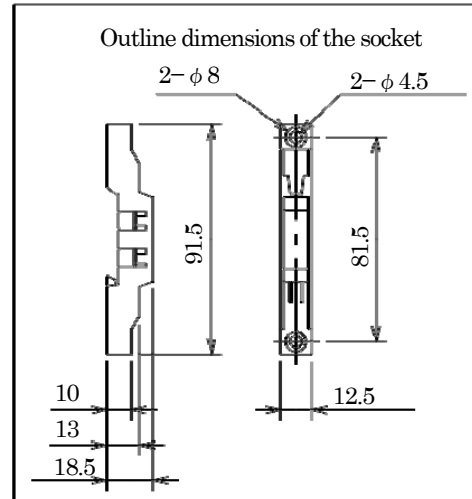
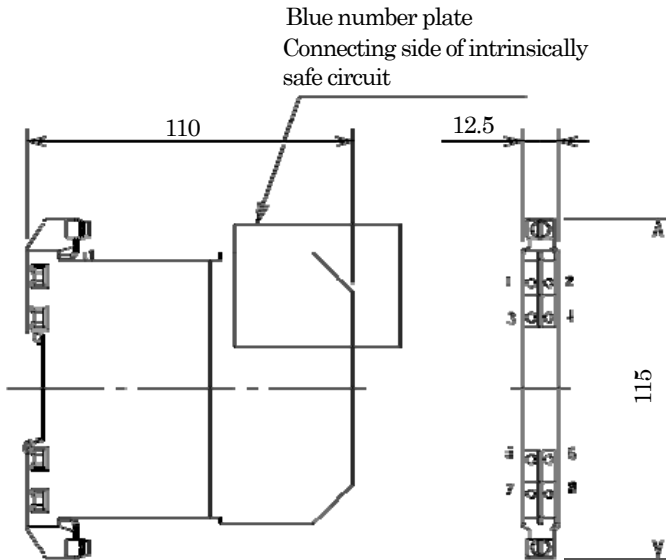

Unit: mm

5. Mounting method

Mounting on DIN rail

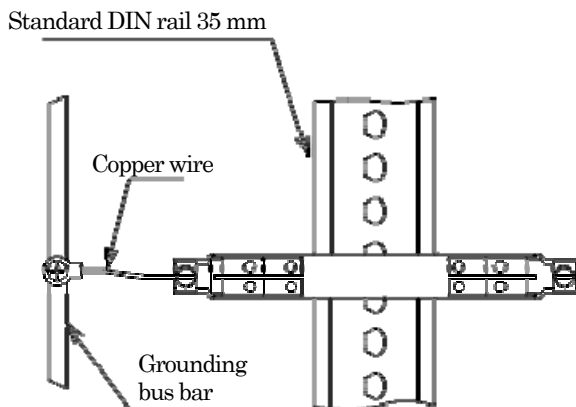

Mounting to installation panel
(Apply the optional socket.)

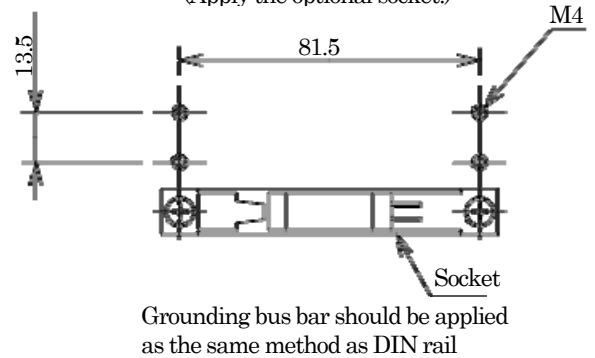

SPECIFICATIONS

Z964-TC20163

Spec. No. EN3538913-B

3/4

6. Wiring diagram

4 – wires method

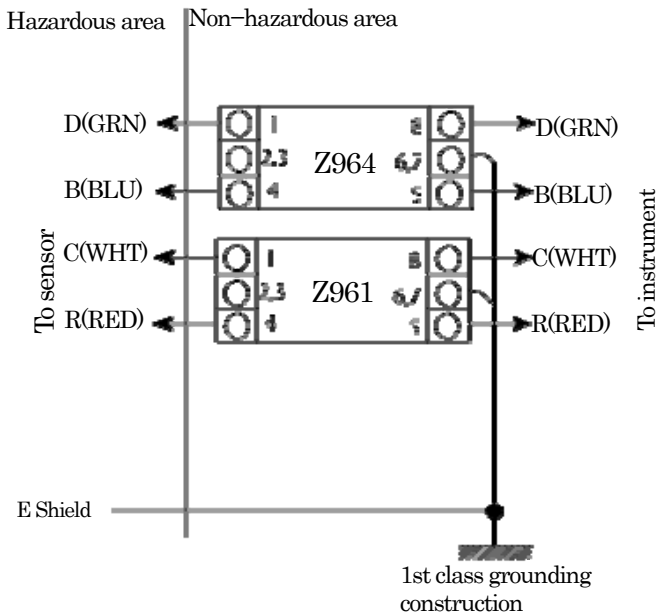

6 – wires method

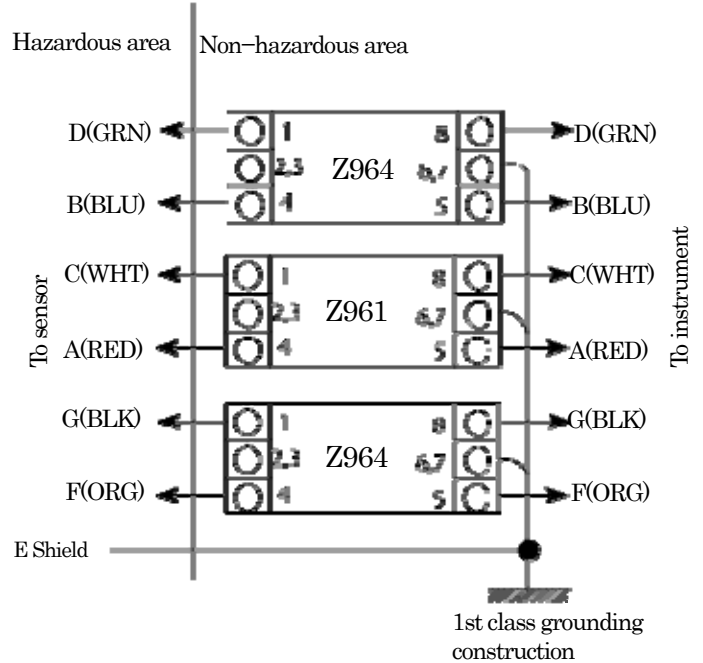

6-1. Contents of color of cable cores

- (GRN): Output of sensor(+)
 - (RED): Inut of sensor(+)
 - (ORG): Remote sensing(+)
 - (BLU): Output of sensor(-)
 - (WHT): Input of sensor(-)
 - (BLK): Remote sensing(-)
- It is recommended to use the bar type terminal for end of cable.
- Reference image



SPECIFICATIONS

7. Internal Circuit

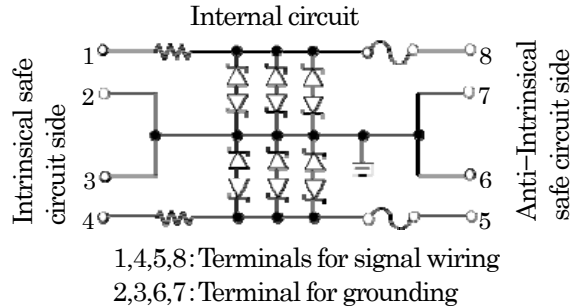

8. Notes

- There are limitations for the applicable sensor, so contact with Minebea beforehand when the barrier is scheduled to be applied.
- As for grounding bus bar, select the one which specifies more than 10 mm (width) and also more than 3 mm in thickness. And surface treatment for prevention from oxidation (ex. nickel plating) should be recommended.
- Grounding is decided as single 1st class construction (Grounding resistance: 10 Ω or less).
- Grounding bus bar, DIN rail and copper wire are not included with this barrier.
- General purpose instrument which is used with the Zener barrier should not exceed AC250 V 50/60 Hz and DC250 V, and even whether the electric potential against the earth for the voltage at internal instrument is normal or abnormal.
- Inductance for outer wiring of intrinsic safe circuit should be less than 0.6 mH and its capacitance should be less than 0.1 μF.
- In case of application of the Zener barrier with 4 wires method, use one piece of Z961 and 1 piece of Z964 for one set. However, in case of application of 6 wires method, use one piece of Z961 and 2 pieces of Z964 for one set.
- When connecting the barrier, use the microdriver whose width of cutting edge specifies 3 mm or less.

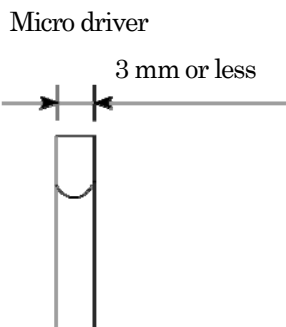

※Specifications and outline dimensions and so on which have printed may subject to change for the purpose of improvement without notice.