

Specifications

Digital Peak Holder

CSD-709

Spec No. EN382709-E

1/20

1. General

This instrument is a Digital Peak Holder with the panel size of 96 mm x 48 mm designed for strain gage applied transducer.

2. Specifications

2-1. Specifications for analog section

- Bridge power supply 10 VDC \pm 0.5 VDC within 60 mA (Changeable to 5 VDC or 2.5 VDC.)
- Applicable transducer Strain gage applied transducer for 170 Ω ~ 1 000 Ω
(at 10 VDC of bridge power supply.)
 - At 10 VDC Up to 2 pieces of strain gage applied transducers (350 Ω) can be connected to the equipment in parallel..
 - At 5 VDC Up to 4 pieces of strain gage applied transducers (350 Ω) can be connected to the equipment in parallel..
 - At 2.5 VDC Up to 8 pieces of strain gage applied transducers (350 Ω) can be connected to the equipment in parallel..
- Input sensitivity 0.4 μ V/d (d = Minimum scale)
- Input range -3.1 mV/V to 3.1 mV/V
- Zero adjustment range \pm 2.5 mV/V
- Monitoring output Approx. 2 V per 1 mV/V of sensor input
(At DC10 V of Bridge power supply)
Load resistance: 2 k Ω or more.
- Non-linearity 0.02 %F.S. \pm 1 digit
- Temperature coefficient
 - Zero point \pm 0.5 μ V/ $^{\circ}$ C
(for the calibration at 0.4 μ V/d or higher of input sensitivity.)
 - Sensitivity \pm 0.0025%F.S./ $^{\circ}$ C
(for the calibration at 0.4 μ V/d or higher of input sensitivity.)
- Analog filter 100Hz
(Changeable to 10 Hz, 40 Hz, 400 Hz, 1 kHz, 4 kHz, 10 kHz or 30 kHz)
-3 dB \pm 1 dB
* Effective only when analog peak hold is used.
* Fixed to 30 kHz when digital peak hold is used.
- Digital low pass filter 40 times/s: Off, 0.1 Hz to 4 Hz
400 times/s: Off, 1 Hz to 40 Hz
4 000 times/s: Off, 10 Hz to 2 000 Hz
- A/D sampling speed 4 000 times/s (Changeable to 40 times/s or 400 times/s)
- A/D internal resolution 24 bit
- CHECK Approx. 0.3 mV/V
(The value can be set by 0.1 mV/V interval in the range from approx. 0.1 mV/V to 2.0 mV/V.)
* This can be applied within 30 m of extension cable CAB-502 (4-cores) of MinebeaMitsumi's standard.
* This requirement is not applied when the zener barrier is used.

Specifications

CSD-709

Spec No. EN382709-E

2/20

- Analog peak hold
Response speed



According to the property of analog filter.

Analog filter set value	10 Hz	40 Hz	100 Hz	400 Hz	1 kHz	4 kHz
Accuracy	Analog filter set value (-3 dB ± 1 dB) ±0.1 %					
Analog filter set value	10 kHz					
Accuracy	Analog filter set value (-3 dB ± 1 dB) ±0.5 %					
Analog filter set value	30 kHz					
Accuracy	Analog filter set value (-3 dB ± 1 dB) ±1 %					

2-2. Specifications for digital section

- Main display (Load display)
 - Display range -99999 ~ 99999
 - Display increment 1 (Changeable to 2, 5 or 10.)
 - Display unit Green 7 segment LED, Character height: 17 mm
 - Over display [-OL] appears in case of minus overflow, [OL] appears in case of plus overflow.
 - AD value over display [-OVF] appears in case of minus overflow, [OVF] appears in case of plus overflow.
- Status display SEL.1, SEL.2, CHECK, HOLD, PEAK, MEAS., END, LOCK
- Judgement display OUT1, OUT2, OUT3, OUT4
- Display rate 20 times/s (Changeable to 4 times/s, 50 times/s or 100 times/s)
- Decimal point display Changeable to [No display], 10¹, 10², 10³ or 10⁴.

2-3. Function of front panel key switches

- FUNC.** Shifts to Function mode
/ Shifts to simple calibration setting mode (By pushing for 2 seconds or more).
- CAL-Z/◀** Shifts to simple calibration ZERO mode (By pushing for 2 seconds or more).
/ Shifts to simple calibration lock mode (By pushing both  and  for 2 seconds or more at the same time.)
/ Carry-up the setting value.
- CAL-S/▲** Shifts to simple calibration SPAN mode (By pushing for 2 seconds or more).
/ Set value increment.
- PEAK/TRACK** During all section specified mode, shift of track mode and various hold mode (Peak, Bottom, Peak/Bottom, Peak to peak, Maximum value, Minimum value, Maximum-Minimum difference, Average value and Inflection point)
Otherwise, control of hold section in the section designation mode or time and section designation mode.
- RESET/CHECK** Reset of peak value. The display is fixed to [0] when this key is being turned on.
/ Turn on and off the CHECK value.
- F/↵** Select from [Off], [Hold], [Zero set], [Zero set clear], [Print command], [COMP setting mode], [Confirmation of CC-Link station number], [Confirmation of RS-422/RS-485 ID], and [Forced termination of multi-hold].
/ Register the set value.

Specifications

CSD-709

Spec No.EN382709-E

3/20

2-4. External control function

(1) Input signal of external control

You can select any of six signals among those listed below.

- Off
- Zero set
- Zero set clear
- Hold (Pulse)
- Print command (Serial interface)
- Forced termination of multi-hold

* Above are the pulse input, and the function becomes effective once when the pulse input width is 50 ms or longer. (The pulse width can be changed to 1 ms, 2 ms, 5 ms, 10 ms or 20 ms.)

- Hold (Level)
- Peak/Truck
- Reset
- SEL.1
- SEL.2
- CHECK
- Batched key lock

* Above are level input, and the function becomes effective while the level that is 50 ms or longer is being input at the time of short-circuit.

(The level width can be changed to 1 ms, 2 ms, 5 ms, 10 ms, or 20 ms.)

(2) Connection of external control input

The external control input circuit is classified into two types: no-voltage contact input type (standard) and voltage input type (option).

- No voltage contact type

This circuit inputs signals by short-circuiting / opening the path between the input terminal and COM1 terminal.

To conduct short-circuiting in this type, use contacts (e.g., relay and switch) and contactless outputs (e.g., open collector output).

When you connect the transistor, use the sink type for the connection.

- Equivalent circuit

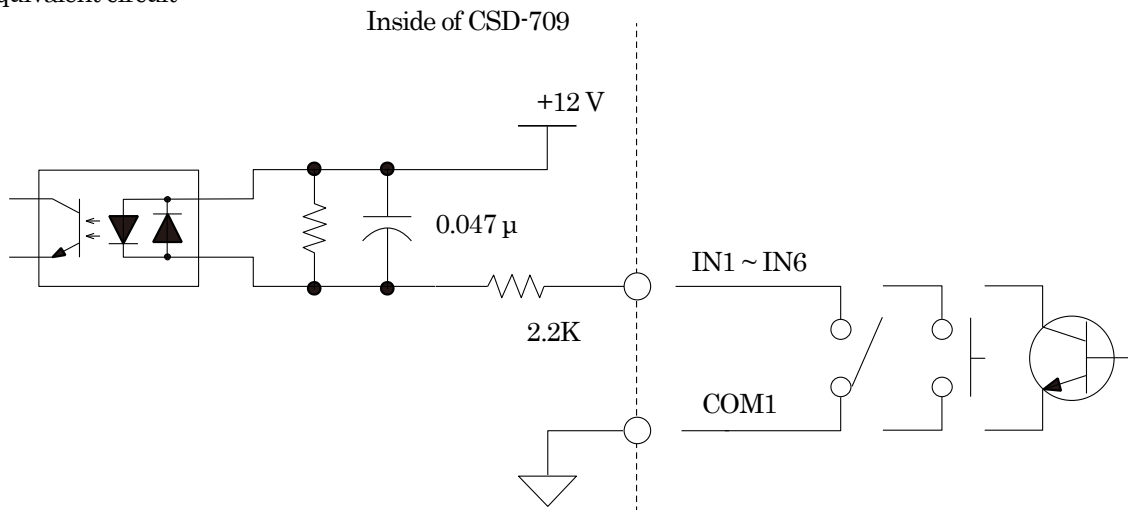

Internal power supply voltage: 12 VDC and short-circuit current: Approx. 5 mA

Specifications

CSD-709

Spec No. EN382709-E

4/20

(3) External control output signals

You can select any of six signals among those listed below.

- OFF
- HOLD
- PEAK (turned on interlocking with the status display)
- MEAS. (turned on interlocking with the status display)
- END (turned on interlocking with the status display)
- MULTI (turned on in using multi-hold mode)
- EXCUTE (turned on during measurement in multi-hold mode)
- OK (turned on when "lower limit < current load < upper limit" is met)
- NG (turned on under any condition, except for OK condition)
- Upper/lower limit (turned on under [upper limit \leq current load] and [current load \leq lower limit])
- S0
- S1
- S2
- ERROR
- Over error (\pm OL, \pm OVF)
- Zero set response (turned off after elapse of 500 ms)
- RUN (level)
- RUN (toggle)

(4) Connection of external control output

The external control output circuit supports the photo MOS relay output.

Plus common connection or minus common connection can be established.

- Equivalent circuit

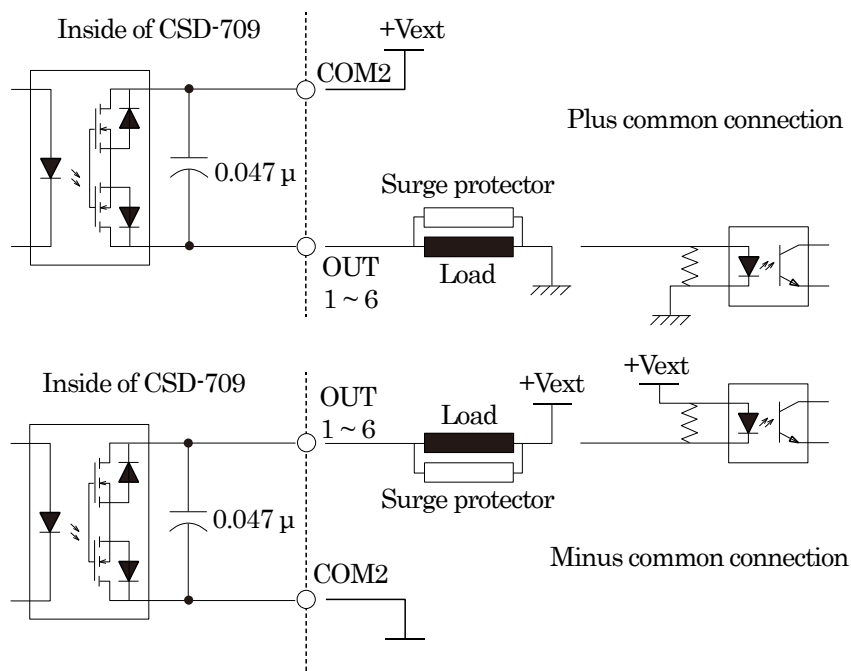

Maximum rated voltage: 30 VDC and maximum rated current 100 mA

Specifications

CSD-709

Spec No. EN382709-E

5/20

2-5. Comparator function

- Set value -99 999 ~ 99 999
- Number of setting 3 (S0, S1 and S2)
- Hysteresis data set value 0 ~ 99 digits
- Hysteresis time width setting 0 ~ 9.9 s
- Direction of hysteresis Selectable from [ON delay] and [OFF delay]
- Comparator conversion frequency
Synchronized with A/D sampling
- Comparator operation target [PEAK] or [TRACK] can be set independently.

2-6. Function

- Analog filter A low-pass filter that utilizes resistors and capacitors to attenuate those frequency components higher than the set frequency. This filter is enabled only when the analog peak hold is used.
- Digital filter A filter that stabilizes the fluctuation during the moving-average process with the CPU.
- Digital low pass filter A low-pass filter used in the operation by the CPU. This filter attenuates those frequency components higher than the set frequency. (Bessel characteristic secondary low-pass filter)
- Simplified calibration Holding down [FUNC.], [CAL-Z] and [CAL-S] respectively for at least two seconds allows you to enter the desired parameter setting screen or calibration screen.
- Communication calibrator You can execute the calibration based on communications through the interface (optional RS-232C, RS-422/485, or CC-Link) without key operation.
- CHECK value An additional load equivalent to the set value. Using this value, for example, in the pre-work check, allows you to confirm the original calibration status is maintained.
- Hold target change You can combine [Display], [Comparison output], [Current output (option)], [Voltage output (option)], [BCD output (option)], [CC-Link (option)], and [Serial interface (option)] to define the resulting combination as the hold target.
- Analog output target change You can select "Track" or "Peak" as the analog output target.
- Brand code change You can memorize up to four different types of calibration data or comparator settings, then select the desired item using functions or external control inputs (SEL.1 and SEL.2).
- Peak mode selection You can select the peak detection mode from 36 modes configured through a combination of nine hold modes (peak hold, bottom hold, peak-bottom hold, peak-to-peak hold, maximum hold, minimum hold, maximum-minimum difference hold, average hold, and four inflection point holds) and four section modes (entire section, specified section, time-specified section, and automatic start time-specified section).
- Digital peak hold You can acquire the peak load through high-speed sampling of up to 4 000 times/s.
- Analog peak hold You can acquire the peak load more speedily independent of the sampling rate. However, the analog circuit equipped with capacitors is used to execute the peak hold, and thus there are some restrictions (e.g., the current load cannot be determined).
- Monitor output This function outputs approximately 2 V per 1 mV/V (when bridge power supply is 10 VDC.) before A/D conversion of the input signal from strain gage type transducer.

Specifications

CSD-709

Spec No. EN382709-E

6/20

- Monitor mode This mode converts the load currently applied to the sensor into a value expressed in mV/V and displays the result. It is effective in finding the cause when the displayed load is abnormal or unstable.
- Waveform comparison After an additional memory (option) is mounted, you can judge the integrity of the measurements using upper and lower limits determined with the specialized application and comparison waveforms.
- Measurement result log After an additional memory (option) is mounted, you can record comparison judgment results as well as time stamps.

2-7. USB interface (for connection with EzCTS and specialized application)

- Specifications Compatible with USB2.0 (can also be used with USB1.1 compatible equipment)
 - Output connector B type mini-USB connector
- * To use USB interface, you must install the specialized driver to the PC used as host.

3. General specifications

- Operating temperature/humidity range
 - Temperature -10 °C to 50 °C
 - Humidity 85 %RH or less (No condensation is permitted.)
- Power supply
 - Power supply voltage 100 VAC to 240 VAC (Permissible variable range 85 VAC to 264VAC)
 - Power supply frequency 50/60Hz
 - Power consumption Approx. 10 VA (without options, at 100 VAC)
Approx. 18 VA (with options at 100 VAC to 240 VAC)
- Inrush Current
 - AC configuration 5 A (1 ms) in 100 VAC average load condition (Ordinary temperature and cold start)
10 A (1 ms) in 200 VAC average load condition (Ordinary temperature and cold start)
- External dimensions 96 mm (W) × 48 mm (H) × 110 mm (D) (excludes protruding parts)
- Dustproof waterproof specification IP64 at the front panel section.
- Weight Approx. 500 g (without any options)

4. Standard shipment specifications

- Bridge power supply DC10 V
- Span adjustment [30000] is displayed at the input of 3.0 mV/V
- Minimum scale 1

Specifications

CSD-709

Spec No. EN382709-E

7/20

5. Accessories

- Start guide (in Japanese) 1 piece
- Start guide (in English) 1 piece
- Midget fuse 1 piece (2.5 A)
- Unit seal 1 piece
- I/O connector for external control
1 piece
- Plug for strain gage type transducer
1 piece
- BCD output plug 1 piece (Available only when the optional BCD card output is installed.)
- Voltage output plug 1 piece (Available only when the optional voltage output card is installed.)
- Current output plug 1 piece (Available only when the optional current output card is installed.)
- RS-232C plug 1 piece (Available only when the optional RS-232C card is installed.)
- Rs-422/485 plug 1 piece (Available only when the optional RS-422/485 card is installed.)
- Serial interface plug 1 piece (Available only when the optional serial interface card is installed.)
- CC-Link plug 1 piece (Available only when the optional CC-Link interface card is installed.)
- CD-ROM *(CSD-709D-01, EzCTS)
1 piece (Available only when the optional additional memory is installed.)
- USB cable 1 piece (Available only when the optional additional memory is installed.)

* The CD-ROM attached when the optional additional memory is mounted in the CSD-709 includes both of the dedicated application CSD-709D-01 and the EzCTS.

Specifications

CSD-709

Spec No. EN382709-E

8/20

6. Options

6-1. Current output

- Parts No. CSD709-P07
- Specifications
 - Output 4 mA to 20 mA
 - Load resistance 510 Ω or less
 - Resolution 1/12 000 or more
 - Non-linearity within 0.025%F.S.
 - Over range Approx. DC 2.4 mA under display of [-OL],
Approx. DC 21.6 mA under display of [OL]
 - Output cycles Synchronous with A/D sampling
 - Effect due to temperature Zero point within 0.5 μA/°C
 - Sensitivity within 0.005 %F.S./°C
- Connector pin configuration of Current output

PinNo.	Signal Name	Description
1	+	Current output (+)
2	-	Current output (-)
3	F.G.	Frame ground

* An internal circuit is insulated by photocoupler

* Applicable plug :MSTB 2,5/3-STF-5,08 (made by PHOENIX CONTACT)

6-2. Voltage output

- Parts CSD709-P29
- Specifications
 - Output ±10 VDC
 - Load resistance 2 kΩ or more
 - Resolution 1/12 000 or more
 - Non-linearity 0.025 %F.S.
 - Over range Approx. -11 VDC at [-OL] display and approx. 11 VDC at [OL] display
 - Output times Synchronous with the A/D sampling times.
 - Effect due to temperature Zero point within 0.6 mV/°C
 - Sensitivity within 0.005 %F.S./°C
- Connector pin configuration of Voltage output

PinNo.	Signal Name	Description
1	+	Current output (+)
2	-	Current output (-)
3	F.G.	Frame ground

* An internal circuit is insulated by photocoupler

* Applicable plug :MSTB 2,5/3-STF-5,08 (made by PHOENIX CONTACT)

Specifications

CSD-709

Spec No. EN382709-E

9/20

6-3. BCD output (Sink type)

- Parts CSD709-P15

- Specifications

Output

BCD 5 digits, parallel output, Accompanied by polarity
(Output is turned on at minus and turned off at plus.)

P.C.(Print command) :

Turned on for a given period after completion of BCD output conversion.

ERROR: Turned on whenever any error occurs.

OVER

Output cycles

Changeable to 4 times/s, 20 times/s, 50 times/s, 100 times/s, 400 times/s,
1 000 times/s, 2 000 times/s or 4 000 times/s

Input

SEL.1,SEL2

Desired brand code is selectable.

HOLD

Display and BCD output is held.

BCD-ENABLE

BCD-related outputs are forcibly turned off

(high impedance).

- Connector pin configuration of BCD output

PinNo.	Signal Name	PinNo.	Signal Name
A1	COM	B1	COM
A2	1 x 10 ⁰	B2	2 x 10 ⁰
A3	4 x 10 ⁰	B3	8 x 10 ⁰
A4	1 x 10 ¹	B4	2 x 10 ¹
A5	4 x 10 ¹	B5	8 x 10 ¹
A6	1 x 10 ²	B6	2 x 10 ²
A7	4 x 10 ²	B7	8 x 10 ²
A8	1 x 10 ³	B8	2 x 10 ³
A9	4 x 10 ³	B9	8 x 10 ³
A10	1 x 10 ⁴	B10	2 x 10 ⁴
A11	4 x 10 ⁴	B11	8 x 10 ⁴
A12	SEL.1	B12	SEL.2
A13	POL.	B13	OVER
A14	ERROR	B14	P.C
A15	HOLD	B15	BCD-ENABLE
A16	N.C.	B16	N.C.

* The card is insulated from the internal circuit by means of a photocoupler.

* Applicable plug: Connector: FCN-361J016-AU (made by Fujitsu) or

N361J016AU (made by OTAX),

Connector cover: FCN-360C016-B (made by Fujitsu) or

N360C016B (made by OTAX)

Specifications

CSD-709

Spec No. EN382709-E

10/20

- Timing chart
- (1) Measurement mode

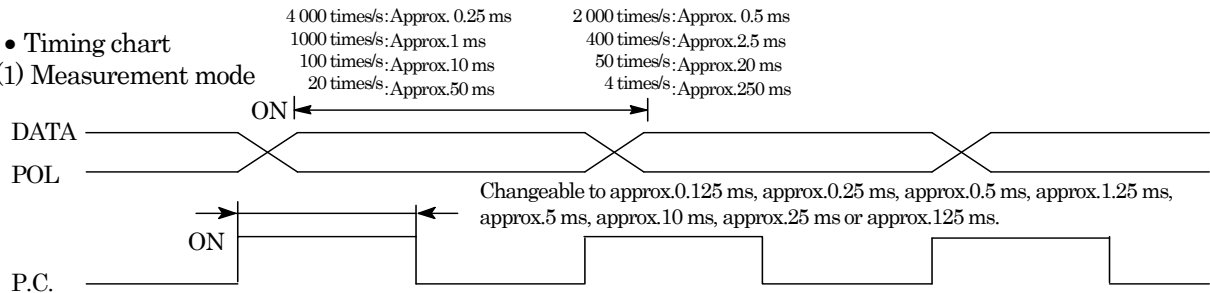

* Output transistor turns ON (Negative logic in electrical theory) when all of the P.C., DATA and POL output the data.

- (2) When data is over (\pm OL display)

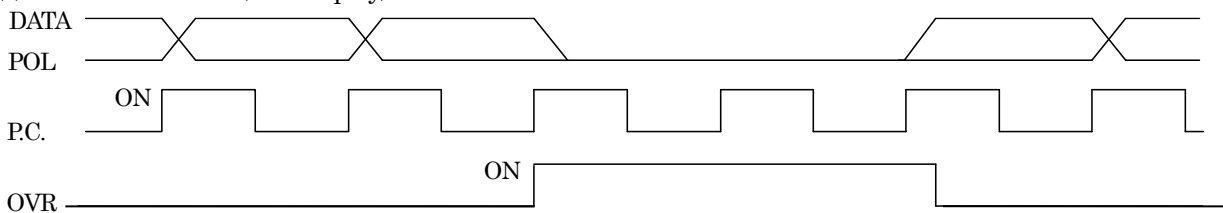

* Output transistor of OVR signal turns ON (Negative logic in electrical theory) while OVR is output.

Moreover, for all DATA when OVR is output, the output transistor becomes OFF status (Positive logic in electrical theory)

- (3) When the error is occurred.

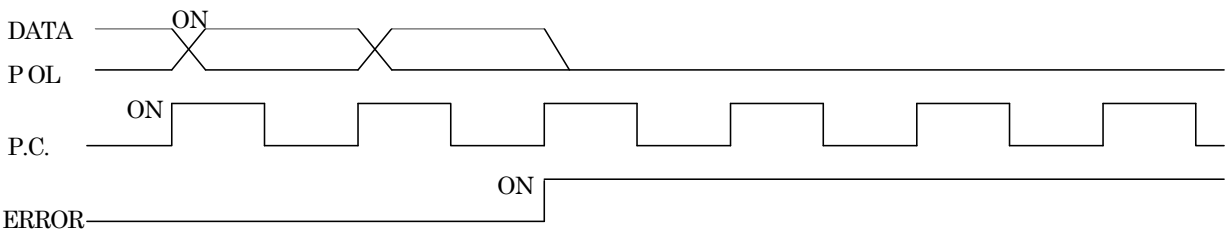

* Output transistor of ERROR signal turns on (Negative logic in electrical theory) while ERROR is output.

Moreover, for all DATA and POL when ERROR is output, the output transistor becomes OFF status (Positive logic in electrical theory).

- (4) When HOLD signal is input.

4 000 times/s: Approx. 0.25 ms at max. + Input response time	4 000 times/s: Approx. 0.25 ms at max. + Input response time
2 000 times/s: Approx. 0.5 ms at max. + Input response time	2 000 times/s: Approx. 0.5 ms at max. + Input response time
1 000 times/s: Approx. 1 ms at max. + Input response time	1 000 times/s: Approx. 1 ms at max. + Input response time
400 times/s: Approx. 2.5 ms at max. + Input response time	400 times/s: Approx. 2.5 ms at max. + Input response time
100 times/s: Approx. 10 ms at max. + Input response time	100 times/s: Approx. 10 ms at max. + Input response time
50 times/s: Approx. 20 ms at max. + Input response time	50 times/s: Approx. 20 ms at max. + Input response time
20 times/s: Approx. 50 ms at max. + Input response time	20 times/s: Approx. 50 ms at max. + Input response time
4 times/s: Approx. 250 ms at max. + Input response time	4 times/s: Approx. 250 ms at max. + Input response time

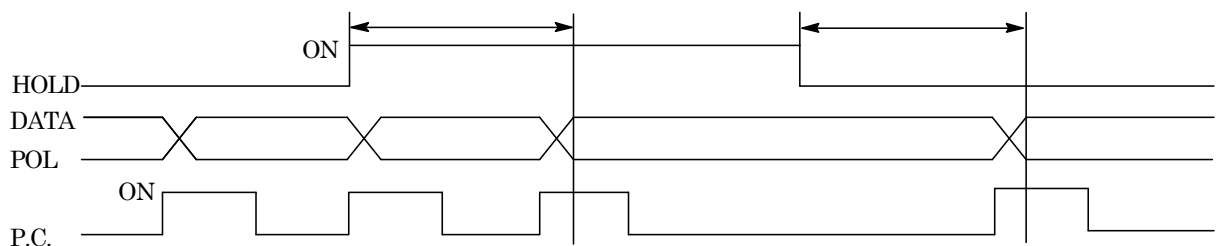

* Output transistor of P.C. turns off (Positive logic in electrical theory) while HOLD signal is input.

* The response time showing above will take for HOLD or reset of DATA and POL., after HOLD signal is input. (The input response time is set by function.)

4 000 times/s: Approx. 0.25 ms at max. + Input response time	2 000 times/s: Approx. 0.5 ms at max. + Input response time
1 000 times/s: Approx. 1 ms at max. + Input response time	400 times/s: Approx. 2.5 ms at max. + Input response time
100 times/s: Approx. 10 ms at max. + Input response time	50 times/s: Approx. 20 ms at max. + Input response time
20 times/s: Approx. 50 ms at max. + Input response time	4 times/s: Approx. 250 ms at max. + Input response time

Specifications

CSD-709

Spec No. EN382709-E

11/20

6-4. BCD output (Source type)

- Parts CSD709-P16
- Specifications
 - Output BCD 5 digits, parallel output, Accompanied by polarity (POL).
(Output is turned on at minus and turned off at plus.)
P.C.(Print command) :
Turned on for a given period after completion of BCD output conversion.
ERROR: Turned on whenever any error occurs.
OVER
 - Output cycles Changeable to 4 times/s, 20 times/s, 50 times/s, 100 times/s, 400 times/s,
1 000 times/s, 2 000 times/s or 4 000 times/s
 - Input
 - SEL.1,SEL2 Desired brand code is selectable.
 - HOLD Display and BCD output is held.
 - BCD-ENABLE BCD-related outputs are forcibly turned off
(high impedance).
- Connector pin configuration of BCD output

PinNo.	Signal Name	PinNo.	Signal Name
A1	+24 V	B1	+24 V
A2	1 x 10 ⁰	B2	2 x 10 ⁰
A3	4 x 10 ⁰	B3	8 x 10 ⁰
A4	1 x 10 ¹	B4	2 x 10 ¹
A5	4 x 10 ¹	B5	8 x 10 ¹
A6	1 x 10 ²	B6	2 x 10 ²
A7	4 x 10 ²	B7	8 x 10 ²
A8	1 x 10 ³	B8	2 x 10 ³
A9	4 x 10 ³	B9	8 x 10 ³
A10	1 x 10 ⁴	B10	2 x 10 ⁴
A11	4 x 10 ⁴	B11	8 x 10 ⁴
A12	SEL.1	B12	SEL.2
A13	POL.	B13	OVER
A14	ERROR	B14	P.C
A15	HOLD	B15	BCD-ENABLE
A16	0 V	B16	0V

* The card is insulated from the internal circuit by means of a photocoupler.

* Applicable plug: Connector: FCN-361J016-AU (made by Fujitsu) or
N361J016AU (made by OTAX),
Connector cover: FCN-360C016-B (made by Fujitsu) or
N360C016B (made by OTAX)

Specifications

CSD-709

Spec No. EN382709-E

12/20

• Timing chart

(1) Measurement mode

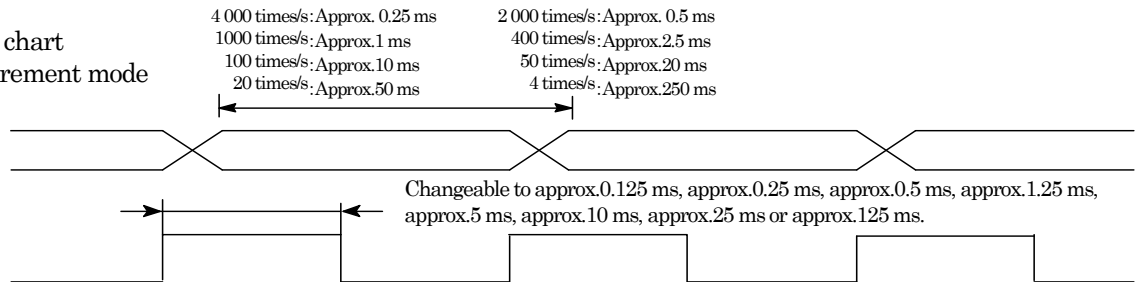

* Output transistor turns ON (Negative logic in electrical theory) when all of the P.C., DATA and POL output the data.

(2) When data is over (\pm OL display)

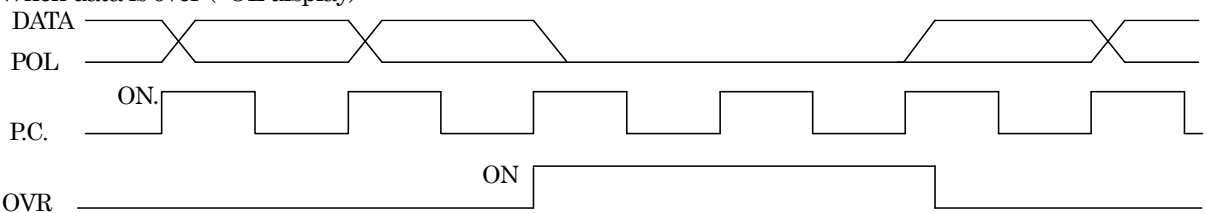

* Output transistor of OVR signal turns ON (Negative logic in electrical theory) while OVR is output. Moreover, for all DATA when OVR is output, the output transistor becomes OFF status (Positive logic in electrical theory)

(3) When the error is occurred.

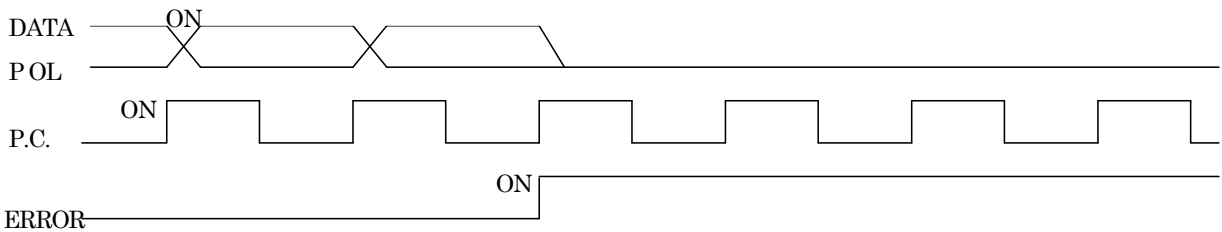

* Output transistor of ERROR signal turns on (Negative logic in electrical theory) while ERROR is output. Moreover, for all DATA and POL when ERROR is output, the output transistor becomes OFF status (Positive logic in electrical theory).

(4) When HOLD signal is input.

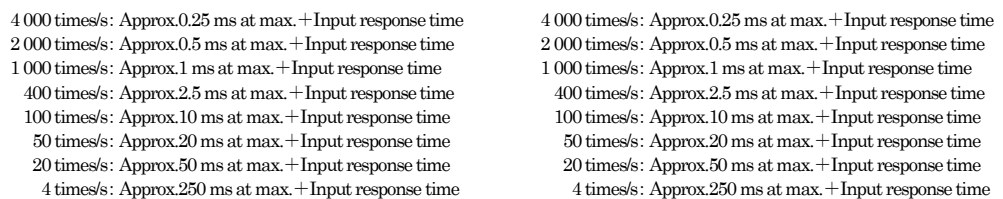

* Output transistor of P.C. turns off (Positive logic in electrical theory) while HOLD signal is input.

* The response time showing above will take for HOLD or reset of DATA and POL., after HOLD signal is input. (The input response time is set by function.)

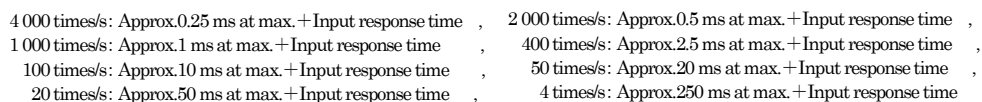

Specifications

CSD-709

Spec No. EN382709-E

13/20

6-5. External control voltage input type

- Parts CSD709-P44
- Voltage input type The voltage is applied between the input terminal and COM1 terminal for signal input. This input by relay, switch, and transistor using the external power supply voltage. When the signals are input with transistors, use the sink type for plus common connections or the source type for minus common connections.
- Equivalent circuit

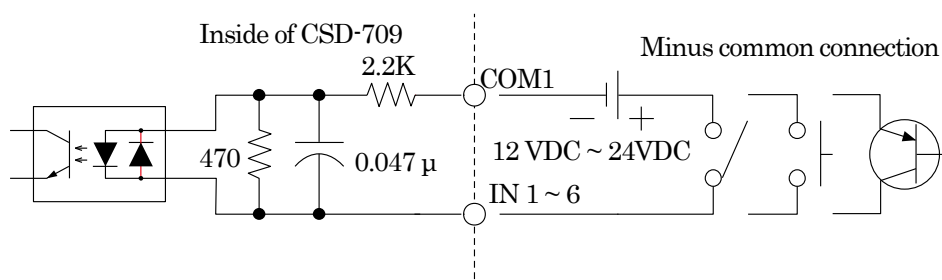
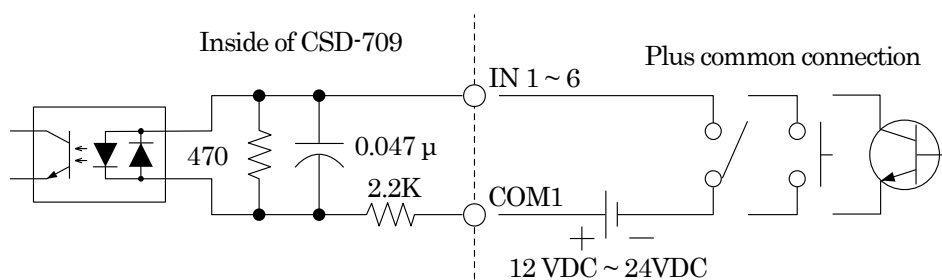

Rated voltage	27.6 VDC at the maximum.
ON condition	9 VDC or more (External power supply voltage: 24 VDC, Load Current: Approx.10 mA)
OFF condition	3 VDC or less

Specifications

CSD-709

Spec No. EN382709-E

14/20

6-6. RS-232C interface

- Parts CSD709-P74
- Specifications
 - Baud rate Selectable from 1 200 bps, 2 400 bps, 4 800 bps, 9 600 bps, 19 200 bps, 38 400 bps, 76 800 bps and 115 200 bps
 - Data bit length Selectable from 7 bit and 8 bit
 - Parity bit Selectable from None, Even and Odd.
 - Stop bit Selectable from 1 bit and 2 bit
 - Terminator Selectable from CR+LF and CR
 - Transmission mode Half duplex
 - Synchronous mode Asynchronous
 - Transmission data ASCII code
 - Cable length within 15 m, Equipped with input/output monitor LED.

- Connector pin configuration of RS-232C output

PinNo.	Signal name	Description
1	DTR	Data terminal ready
2	TXD	Transmission data
3	RXD	Reception data
4	S.G.	Signal Ground

* The card is insulated from the internal circuit by means of a photocoupler.

* Applicable plug: MC 1.5/4-ST-3.81 (made by PHOENIX CONTACT.)

- Function
 - 1) Reading out the load.
 - 2) Reading out the condition
 - 3) Changing the condition
 - 4) Reading out the comparator set value.
 - 5) Change of the comparator set value.
 - 6) Reading out set value of the various function
 - 7) Change the set value of the various function
 - 8) Load calibration
 - 9) Transmission error code

Specifications

CSD-709

Spec No. EN382709-E

15/20

6-7. RS-422/RS-485 interface

- Parts CSD709-P76
- Specifications
 - Baud rate Selectable from 1 200 bps, 2 400 bps, 4 800 bps, 9 600 bps, 19 200 bps, 38 400 bps, 76 800 bps and 115 200 bps
 - Data bit length Selectable from 7 bit and 8 bit
 - Parity bit Selectable from None, Even and Odd.
 - Stop bit Selectable from 1 bit and 2 bit
 - Terminator Selectable from CR+LF and CR
 - Transmission mode Half duplex
 - Synchronous mode Asynchronous
 - Address Select one address within the range from 0 to 31
 - Transmission data ASCII code
 - Cable length Approx. 1 km
 - Numbers of connection Up to 32 units (RS-422: Up to 10 units)
 - Termination Built in (Existence or nonexistence is selected by plugging in the connector board); equipped with input/output monitor LED
 - Change between RS-422 and RS-485 Function is used.
 - Data transmission mode Select from Command, Modbus and Stream.

- Connector pin configuration of RS-422/RS-485 output

PinNo.	Terminal name	Description
1	SDA	Differential output (+)
2	SDB	Differential output (-)
3	RDA	Differential input (+)
4	RDB	Differential input (=)
5	TRM.	Terminal resistance
6	S.G.	Signal ground

* The card is insulated from the internal circuit by means of a photocoupler.

* Applicable plug: MC 1.5/6-ST-3, 81 (made by PHOENIX CONTACT.)

- Function
 - 1) Reading out the load.
 - 2) Reading out the condition
 - 3) Changing the condition
 - 4) Reading out the comparator set value.
 - 5) Change of the comparator set value.
 - 6) Reading out set value of the various function
 - 7) Change the set value of the various function
 - 8) Load calibration
 - 9) Transmission error code

Specifications

CSD-709

Spec No. EN382709-E

16/20

6-8. CC-Link interface

- Parts No. CSD709-P73
- Version of CC-Link Ver.1.10
 - Number of shared stations Selectable from 1, 2 and 4 stations.
- Specifications
 - Baud rate Selectable from 156 kbps, 625 kbps, 2.5 Mbps, 5 Mbps, and 10 Mbps
 - Communication system Poling method
 - Synchronous mode Bit synchronous mode
 - Transmission path RS-485 bus
 - Transmission format Conforming to HDLC
 - Remote station number 01 to 64 when one station is shared.
01 to 63 when two stations are shared.
01 to 61 when four stations are shared.
 - Number of connections Up to 64 units when one station is shared.
Up to 32 units when two stations are shared.
Up to 16 units when four stations are shared.
 - Connecting cable Shielded twisted pair cable. The cable used shall be specialized for for CC-Link.
 - Termination External resistor
 - Status LEDs Communication status is indicated with four associated LED.
(RUN, ERR, SD and RD)
- Connector pin configuration of CC-Link

Pin No.	Signal name	Description
1	DA	Signal cable at DA side
2	DB	Signal cable at DB side
3	DG	Signal cable ground
4	SLD	Shield
5	FG	Frame ground

* Applicable plug: MSTB 2,5/5-ST-5,08 (made by PHOENIX CONTACT)

*[SLD] and [FG] are connected internally.

* The card is insulated from the internal circuit by means of a photocoupler.

Specifications

CSD-709

Spec No. EN382709-E

17/20

- Functions

- 1) Reading out the load.
- 2) Reading out the condition
- 3) Changing the condition
- 4) Reading out the comparator set value.
- 5) Change of the comparator set value.
- 6) Reading out set value of the various function
- 7) Change the set value of the various function
- 8) Load calibration
- 9) Transmission error code

* CC-Link is abbreviation of Control & Communication Link

* Conforming to CC-Link family system profile (CSP+).

6-9. Serial interface (S-I/F)

(2-wire method serial interface)

- Parts No. CSD709-P77
- Specifications
 - Baud rate 600 bps
 - Data bit length 8 bit
 - Parity bit Odd
 - Stop bit 1 bit
 - Star bit 1 bit
 - Transmission data Binary code or BCD

- Connector pin configuration of S-I/F

Pin No.	Signal name	Description
1	S-I/F (+)	Connect this pin to the serial interface terminal (+) of the device to be plugged in.
2	S-I/F (-)	Connect this pin to the serial interface terminal (-) of the device to be plugged in.
3	F.G.	Frame ground

* The card is insulated from the internal circuit by means of a photocoupler.

* The external control input and common is connected internally.

* Applicable plug: MC 1,5/3-ST-3,81 (made by PHOENIX CONTACT.)

6-10. Additional memory

- Parts No. CSD709-P91
- Functions
 - 1) Comparator judgement result can be stored.
 - 2) Peak data can be stored.
 - 3) Error log can be stored.
 - 4) Calendar function is available.
 - 5) Comparison waveform of upper and lower limit judgement can be stored.

* Reading the stored data and the waveform simulation is available using the specialized software (CSD-709D-01).

* CSD-709D-01 and EzCTS are provided.

* Refer to 6-12 for EzCTS.

Specifications

CSD-709

Spec No. EN382709-E

18/20

6-11. DC power supply voltage

• Parts No.	CSD709-P67
Power supply	10.6 VDC ~ 27.6 VDC
Power consumption	Approx. 3.6 VA (without options, at 24 VDC.) Approx. 3.6 VA (without options, at 12 VDC.) Approx. 4.9 VA at the maximum (with options at 20.4 VDC ~ 27.6 VDC) Approx. 4.9 VA at the maximum (with options at 10.6 VDC ~ 13.8 VDC)
Inrush Current	8 A (1 ms) in 24 VDC average load condition (Ordinary temperature and cold start) 5 A (1 ms) in 12 VDC average load condition (Ordinary temperature and cold start)

6-12. EzCTS (Ez Communication Tool Software)

The PC that installs EzCTS and connects with CSD-709, can read and write the parameter set with CSD-709.

*Refer to the specifications of EzCTS for the details.

*There are two ways to purchase.

- Purchase only the EzCTS
- Purchase the optional memory expansion.

(The CD-ROM attached when the optional additional memory is mounted in the CSD-709 includes both of the dedicated application CSD-709D-01 and the EzCTS.)

Specifications

CSD-709

Spec No. EN382709-E

19/20

6-13. Optional combinations

P07	Current output (DC4 mA~20 mA)
P29	Voltage output (±10 VDC)
P15	BCD output (Sink type)
P16	BCD output (Source type)
P73	CC-Link interface
P74	RS-232C interface
P76	RS-422/485 interface
P77	Serial interface

* Only one of above options can be mounted.

* P44, P67 and P91 can be mounted regardless as the above-mentioned existence.

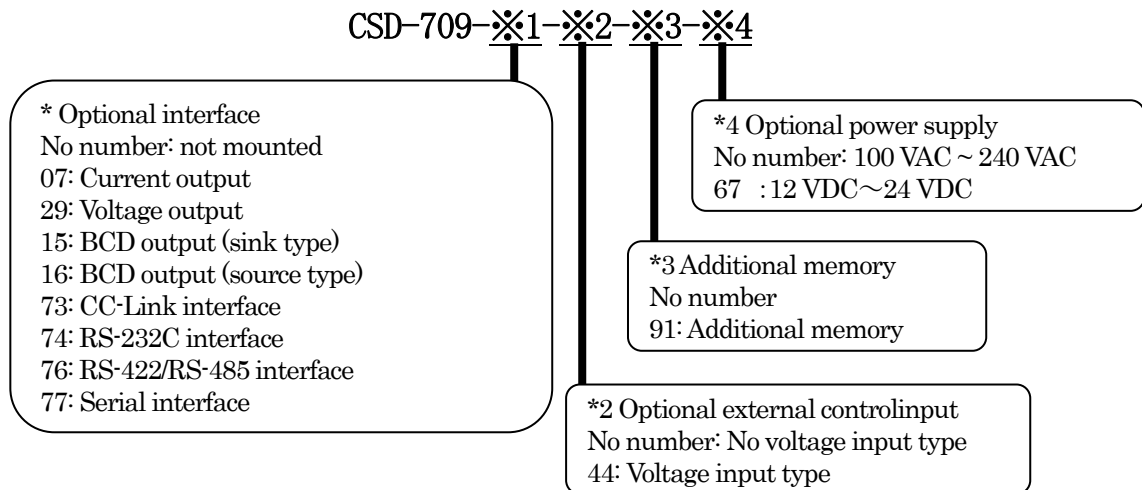

(Ex) CSD-709-29-67: When you order CSD-709 with voltage output and DC power supply voltage of 24 VDC.

Specifications

CSD-709

Spec No. EN382709-E

20/20

7. Outline dimensions

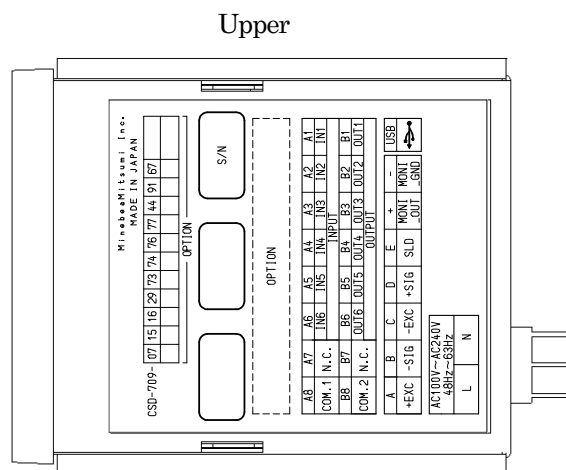
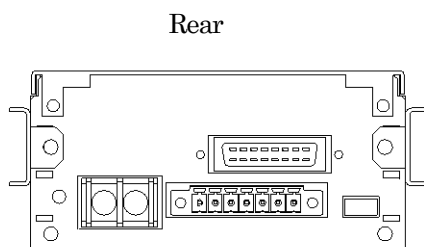
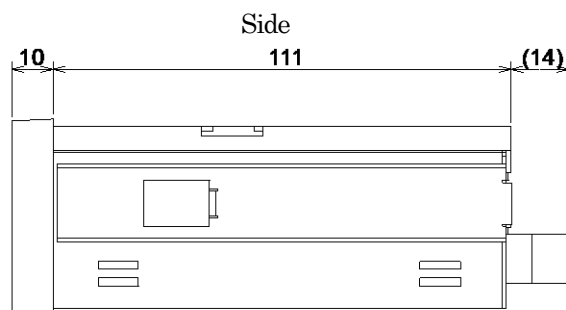
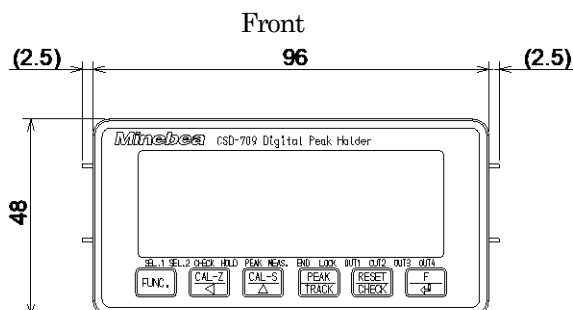

Panel Cut size

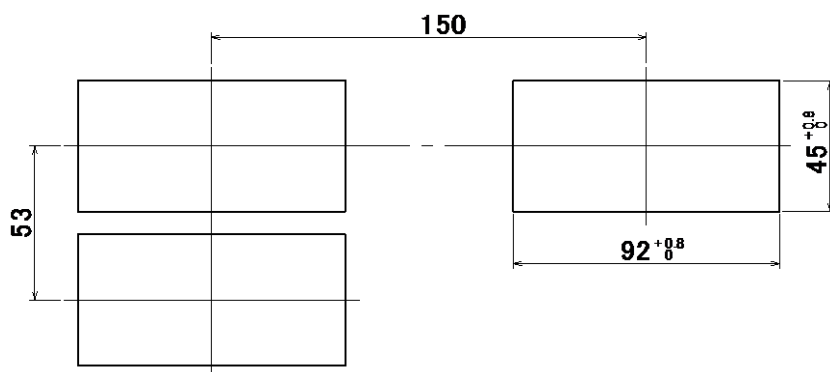

Unit: mm

* Specifications and outline dimensions and so on which have printed may subject to change for the purpose of improvement without notice.