

Minebea

CC-Link

***DIGITAL INDICATOR
CC-Link Interface
CSD-903B-73***

Instruction Manual

Introduction

Thank you very much for your purchasing the digital Indicator, model CSD-903B-73.

This instruction manual describes how to operate the device as well as noteworthy points. Note that handling and operating the device incorrectly may result in malfunctions. Read this manual thoroughly before use for safety and optimal results.

Keep this instruction manual in a location where it is readily accessible to end users.

This manual is intended for the technical experts to read.

When you read this instruction manual, the program basic knowledge of PLC and the CC-Link interface are needed.

Pictograms and conventions used in this manual

This manual uses the following pictograms to indicate actions to avoid at all times, aspects requiring caution, and other noteworthy matters.

Be sure to read the descriptions provided alongside these pictograms.



WARNING

This indicates circumstances in which incorrect handling may result in death or serious injury to users. Avoid the actions described here at all times.



CAUTION

This indicates circumstances in which incorrect handling may result in injury to users or damage to property.



This indicates operating or procedural precautions or restrictions. Always read the details included here to avoid malfunctioning.

About the view of this book

This instruction manual explains the connection method and use of the CC-Link interface specification of the option for CSD-903B. Please see the CSD-903B instruction manual about the other functions and a basic method of handling and notes.

CSD-903B instruction manual (DRW NO. EN294-2043*)

Moreover, please refer to the instruction manual of PLC and its CC-Link interface for the PLC program and CC-Link.

- CC-Link is an abbreviation of “Control & Communication Link”
- This product supports CSP+ (CC-Link Family System Profile Plus).

Please download CSP+ file from the following URL if required.

<https://product.minebeamitsumi.com/en/product/category/mcd/instrumentation/i-amp/parts/DigitalIndicatorCSD903BEX.html>

In addition, please refer to HP of the MITSUBISHI ELECTRIC for the details of the CSP+.

Divisional history

Date	Instruction manual No.	Details of revised point
2024/10	DRW. NO.EN294-2062	First Version VER.1.000

Index

Introduction	I
Pictograms and conventions used in this manual	I
About the view of this book	II
Divisional history	III
1. General	1
1-1. Features	1
2. Name and function of each point	2
2-1. Rear panel for CC-Link I/F	2
3. Connecting method	3
3-1. Connector pin configuration for communication	3
3-2. Notes of Connection.....	3
4. Setting of CC-Link connecting	4
4-1. Changeover to Function mode	4
4-2. Items of CC-Link setting.....	4
5. PLC memory explanation	6
5-1. Address	6
5-2. Address map.....	7
6. Function of calibration	28
6-1. Change to Calibration mode by communication	29
6-2. Setting of scale interval.....	29
6-3. Setting of weighing capacity	30
6-4. Setting of mass of weight	30
6-5. Confirmation of ZERO stability.....	31
6-6. ZERO calibration by weight	31
6-7. ZERO calibration by numeric input	32
6-8. Confirmation of SPAN stability	32
6-9. SPAN calibration by weight.....	33
6-10. SPAN calibration by numeric input	34
6-11. End of calibration	34
6-12. Calibration forced finish	35
7. Operation method	36

7-1. Writing the set value	36
7-2. Writing/Reading by general command	36
7-3. Shift to status where it is possible to communicate	37
7-4. Error condition/Reset requesting flag	38
7-5. CPU normal operation signal	38
8. Specifications of interface.....	39
8-1. Specifications of CC-Link interface	39
8-2. Accessories.....	39

1. General

This unit is a remote device station of CC-Link Ver.1.10.

This unit can be connected with the mastering station of CC-Link Ver.1.10.

1-1. Features

Main features for CSD-903B-73 are as follows:

- (1) This unit can be controlled by using remote I/O and register of the PLC, so the program volume of the PLC can be reduced.
- (2) The wiring with the PLC can be reduced.

2. Name and function of each point

2-1. Rear panel for CC-Link I/F

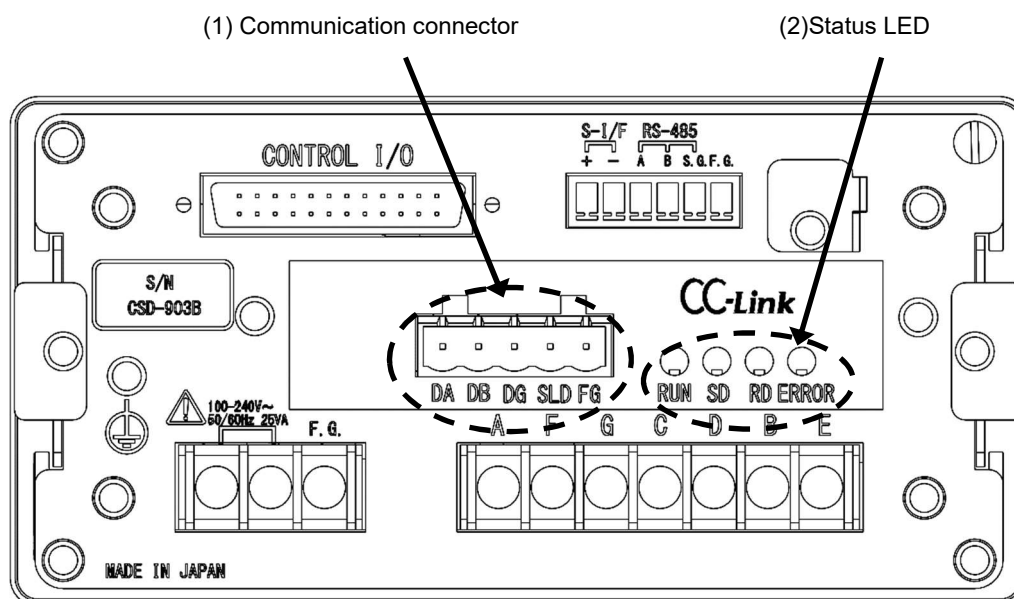

(1) Communication connector

Connector type terminal block for CC-Link interface.

Connector pin configuration for communication is as follows.

Pin No.	Signal name	Contents
1	DA	Signal line DA side
2	DB	Signal line DB side
3	DG	Signal line ground
4	SLD	Shield
5	FG	Frame ground

※ Suitable plug : MSTB 2,5-ST-5,08 AU by PHOENIX CONTACT. ※to be attached.

※ "SLD" and "FG" are connected inside.

※ The internal circuit and photo coupler are insulated.

(2) Status LED

The communication status is expressed with four LED.

LED Name	Light on	Light off	Light on/off
RUN	• Normal	• In the reset • No communication	—
SD	• Transmitting	—	—
RD	• Receiving	—	—
ERR	• Setting error • CRC error • Trouble	• Normal	• When setting changes

3. Connecting method

3-1. Connector pin configuration for communication

Refer to “2-1.Rear panel for CC-Link I/F (1) Connector for communication”.

3-2. Notes of Connection

- When the wiring, be sure to the instrument power supply is OFF.
- Do not supply the AC power until complete the installation. This instrument does not have power switch (ON/OFF).
- Do not fell or make a strong impact on this instrument rear panel terminal block because it is made of resin.
- Striped electrical cable tip length is 6 mm.
- The tightening torque of terminal screws on the terminal block is 0.6 N·m.
- Cables which connecting this instrument isolate from noise sources, for example, power supply line and I/O for control's as much as possible.
- Be sure to connect the ground wire must be D single ground. Do not common the ground with a kind of power supply.
- For CC-Link cable connection, use twist pear cable wire with shield (Cable for CC-link) and connect the shield in terminal block's SLD terminal or F.G. terminal.



- **Connect the termination to the CC-Link connector to electrical termination which is far from PLC as possible.**
- **Use the connecting cable for CC-Link.**
- **Refer to the “Construction and specification of network system” from the latest version of CC-Link Cable Wiring Manual published by CC-Link Partner Association about communication speed and cable length**

4. Setting of CC-Link connecting

Please set the following when you use CC-LINK interface.

4-1. Changeover to Function mode

Change from the standard measurement mode to the function mode by the following operations.

- 1) Press the **SET** key.
- 2) The display becomes "FUNC", and press the **F** key.
- 3) Select function number which you want to change.

Refer to clause 7 of the CSD-903B instruction manual (DRW No.EN294-2043) for "Setting method of the function mode".

4-2. Items of CC-Link setting

Item	Function No.	Setting value	Contents
CC-Link The number of occupied stations	F-84	0	1station occupied
		1	2 stations occupied
		●2	4 stations occupied
CC-Link Setting of the stations	F-85	01~64 ●01	F-84=0 : selectable from station No. 01 to 64. F-84=1 : selectable from station No. 01 to 63. F-84=2 : selectable from station No. 01 to 61.
CC-Link Setting of baud rate	F-86	●0	156 kbps
		1	625 kbps
		2	2.5 Mbps
		3	5 Mbps
		4	10 Mbps
CC-Link 32 bits data expression method	F-87	●0	Expression of standard binary
		1	Most significant bit sign The left end digit is fixed to [8] at [Negative (minus)]

●: This sign means a default setting.

(1) The number of occupied stations (F-84)

Number of occupied stations are set.
Selectable from [1 station], [2stations], [4 stations].
Default has set as [4 stations].

(2) Setting of the stations (F-85)

Execute the setting of the station No.
When 1 station is occupied : selectable from station No.01 to 64.
When 2 stations are occupied : selectable from station No.01 to 63
When 4 stations are occupied : selectable from station No.01 to 61.
The occupied station of this instrument is 1, 2, 4 stations.

※ When 2 stations are occupied, and station No. is set as [01], 01 ~ 02 stations are occupied.

※ When 4 stations are occupied, and station No. is set as [01], 01 ~ 04 stations are occupied.

Therefore, the station number must not overlap.
Default has set as [01].

(3) Setting of baud rate (F-86)

Communication speed (unit: bps) is set.

Selectable from [156k], [625k], [2.5M], [5M] or [10M].

Default has set as [156k].

(4) Signed data indication method (F-87)

32 bits data indication method is set.

Selectable from [Expression of standard binary] or [MSB sign].

Default has set as [Expression of standard binary].

Load value	32 bits data expression method	Upper 16 bit	Lower 16 bit
-1	Expression of standard binary	FFFFH	FFFFH
	MSB sign	8000H	0001H
-10	Expression of standard binary	FFFFH	FFF6H
	MSB sign	8000H	000AH
-99999	Expression of standard binary	FFFEH	7961H
	MSB sign	8001H	869FH

* MSB = Most significant bit



The accumulated value of ten digit display is to be fixed to [Standard binary expression] regardless of the setting of function F-87.

5. PLC memory explanation

5-1. Address

A remote I/O(RX/RX: Bit handling register) and a remote register(RWw/RWr: Word handling register) secures the zone in the master station depends on the occupied station number. As shown in the table below in case of this unit.

Type		Occupied station number			Remarks
		4 stations occupied	2 stations occupied	1 station occupied	
Remote input		128points	64points	32points	I/O for each 16 points is occupied as a system area.
Remote output		128points	64points	32points	
Remote register	Master→Remote	16points	8points	4points	
	Remote→Master	16points	8points	4points	

The address number of the remote station allocated to the mastering station is as shown in the table below.

Station No.	Remote input	Remote output	Remote register		Remarks
			Master→Remote	Remote→Master	
0	-----	-----	-----	-----	Specify the master station
1	RX0000	RY0000	RWw0000	RWr0000	
2	RX0020	RY0020	RWw0004	RWr0004	
3	RX0040	RY0040	RWw0008	RWr0008	
~	~	~	~	~	
10	RX0120	RY0120	RWw0024	RWr0024	
~	~	~	~	~	
64	RX07E0	RY07E0	RWw00FC	RWr00FC	

5-2. Address map

5-2-1. Data detail

(1) Batch/Discharge mode Remote register

4 stations occupied (Master → Instrument)			
Station	Remote register	Contents	Remarks
1	RWwn	(1)Final (24 bit)	Special data area
	RWwn+1	(1)Brand code (8 bit)	
	RWwn+2	(1)Preliminary 2 (32 bit)	
	RWwn+3		
2	RWwn+4	(1)Preliminary 1 (16 bit)	
	RWwn+5	(1) Free Fall (16 bit)	
	RWwn+6	(1)Over (16 bit)	
	RWwn+7	(1)Under (16 bit)	
3	RWwn+8	(1)Full (32 bit)	
	RWwn+9		
	RWwn+A	(1)Near zero (32 bit)	
	RWwn+B		
4	RWwn+C	(2)General data area	
	RWwn+D		
	RWwn+E	(3)Command No. (Return)	
	RWwn+F	(4)Operating mode (Return)	

n : Value decided by setting of station No.

2 stations occupied (Master→Instrument)			
Station	Remote register	Contents	Remarks
1	RWwn	(1)Final (24 bit)	Special data area
	RWwn+1	(1)Brand code (8 bit)	
	RWwn+2	Undefined (16 bit)	
	RWwn+3	(1)Free Fall (16 bit)	
2	RWwn+4	(2)General data area	
	RWwn+5		
	RWwn+6	(3)Command No. (Return)	
	RWwn+7	(4)Operating mode (Return)	

n : Value decided by setting of station No.

1 station occupied (Master→Instrument)			
Station	Remote register	Contents	Remarks
1	RWwn	Undefined	
	RWwn+1		
	RWwn+2		
	RWwn+3		

n : Value decided by setting of station No.



- Please set the stored place to the internal RAM when the set value is continuously changed, and the rewritable time of EEPROM might exceed about one million times.
- Please do not change in the set value under the measurement because the A/D sampling rate decreases temporarily while rewriting the set value. Please set the storing place to the internal ROM when you change the set value during the measurement.

1) Special data area (4 stations, 2 stations)

When the set value is registered by using the set value writing request (request 1), the set value is set in each area.

Details of each set value are shown as follows;

	Data type	Setting range
Final	24 bit binary with sign	0 ~ 999999
Preliminary 2	32 bit binary with sign	0 ~ 999999
Preliminary 1	16 bit binary with sign	0 ~ 32767
Free Fall	16 bit binary with sign	-32768 ~ 32767
Over	16 bit binary with sign	0 ~ 32767
Under	16 bit binary with sign	0 ~ 32767
Full	32 bit binary with sign	0 ~ 999999
Near zero	32 bit binary with sign	0 ~ 999999
Brand code	8 bit binary with sign	0 ~ 7

2) General data area (4 stations, 2 stations)

When the set value or data is registered by using the general command request (request 2), the set value is set in this area

Details of each set value are shown as follows;

	Data type	Setting range
Final	32 bit binary with sign	0 ~ 999999
Preliminary 2	32 bit binary with sign	0 ~ 999999
Preliminary 1	16 bit binary with sign	0 ~ 999999
Free Fall	16 bit binary with sign	-999999 ~ 999999
Over	16 bit binary with sign	0 ~ 999999
Under	16 bit binary with sign	0 ~ 999999
Full	32 bit binary with sign	0 ~ 999999
Near zero	32 bit binary with sign	0 ~ 999999

3) Command No. (4 stations, 2 stations)

When the set value or data is registered by using the general command request (request 2), the command No. is set in this area.

The content of the general data area is set depending on the command set in this command area.

Data type : 8 bit binary

Setting range : 0 ~ 255

4) Operation mode (4 stations, 2 stations)

When the operation mode is changed by using the operation mode changeover request (request 3), the mode number is set in this area.

This function is prepared for future expansion.

Data type : 8 bit binary

Setting range : 0 ~ 255

(2) Remote register of 4 steps comparator mode

4 stations occupied (Master→Instrument)			
Station	Remote register	Contents	Remarks
1	RWwn	(1) S1 (24 bit)	Special data area
	RWwn+1	(1) Brand code (8 bit)	
	RWwn+2	(1) S2 (32 bit)	
	RWwn+3		
2	RWwn+4	(1) S3 (32 bit)	
	RWwn+5		
	RWwn+6	(1) S4 (32 bit)	
	RWwn+7		
3	RWwn+8	(1) Full (32 bit)	
	RWwn+9		
	RWwn+A	(1) Near zero (32 bit)	
	RWwn+B		
4	RWwn+C	(2) General data area	
	RWwn+D		
	RWwn+E	(3) Command No. (Return)	
	RWwn+F	(4) Operating mode (Return)	

n : Value decided by setting of station No.

2 stations occupied (Master→Instrument)			
Station	Remote register	Contents	Remarks
1	RWwn	(1) S1 (32 bit)	Special data area
	RWwn+1	(1) Brand code (8 bit)	
	RWwn+2	(1) S2 (32 bit)	
	RWwn+3		
2	RWwn+4	(2) General data area	
	RWwn+5		
	RWwn+6	(3) Command No. (Return)	
	RWwn+7	(4) Operating mode (Return)	

n : Value decided by setting of station No.

1 station occupied (Master→Instrument)			
Station	Remote register	Contents	Remarks
1	RWwn	Undefined	
	RWwn+1		
	RWwn+2		
	RWwn+3		

n : Value decided by setting of station No.



- Please set the stored place to the internal RAM when the set value is continuously changed, and the rewritable time of EEPROM might exceed about one million times.
- Please do not change in the set value under the measurement because the A/D sampling rate decreases temporarily while rewriting the set

1) Special data area (4 stations, 2 stations)

When the set value is registered by using the Setting value writing request (request 1), the set value is set in each area.

Details of each set value are shown as follows;

	Data type	Setting range
S1	24 bit binary with sign	-999999 ~ 999999
S2	32 bit binary with sign	-999999 ~ 999999
S3	32 bit binary with sign	-999999 ~ 999999
S4	32 bit binary with sign	-999999 ~ 999999
Full	32 bit binary with sign	0 ~ 999999
Near zero	32 bit binary with sign	0 ~ 999999
Brand code	8 bit binary with sign	0 ~ 7

2) General data area (4 stations, 2 stations)

When the set value or data is registered by using the general command request (request 2), the set value is set in this area

Data type : 32 bit binary with sign
Setting range : Depends on the set value.

3) Command No. (4 stations, 2 stations)

When the set value or data is registered by using the general command request (request 2), the command No. is set in this area.

The content of the general data area is set depending on the command set in this command area.

Data type : 8 bit binary
Setting range : 0 ~ 255

4) Operation mode (4 stations, 2 stations)

When the operation mode is changed by using the operation mode changeover request (request 3), the mode number is set in this area.

This function is prepared for future expansion.

Data type : 8 bit binary
Setting range : 0 ~ 255

(3) Command list

The command No. and the value which is set in General data area when the command order is executed by using the general command request (request 2) are shown in the next page.

Writing set value and command order (Writing/reading selection = Writing [OFF])

Setting value or command order	Command No. (RWwnE)	General data area (RWwnC~RWwnD)
Undefined	1	
Undefined	2	
Undefined	3	
Undefined	4	
Undefined	5	
Final /S1	6	
Free fall /S4	7	
Preliminary 1 /S3	8	
Preliminary 2 /S2	9	
Over /S0	10	
Under	11	
Near zero	12	
Full	13	
Preset Tare	14	
Supplementary time	15	
Waiting time for judge after supplementary flow	16	
Automatic free fall compensation	17	
Undefined	18	
Undefined	19	
Accumulation value (8digits)	20	
Accumulation times	21	
Undefined	60	
Undefined	61	
Undefined	62	
Undefined	63	
Undefined	64	
Calibration forced finish	9000	
Change to Calibration mode	9001	
Setting of Scale interval	9002	
Setting of Weighing capacity	9003	
Setting of mass of weight	9004	
Undefined	9005	
ZERO calibration by weight	9007	
ZERO calibration by numeric input	9008	
Undefined	9009	
SPAN calibration by weight	9010	
SPAN calibration by numeric input	9011	
End of calibration	9099	

Setting value or command order	Command No. (RWwnE)	General data area (RWwnC~RWwnD)
Zero	0	1
Zero clear	0	2
Tare	0	3
Tare clear	0	4
Batch start	0	5
Discharge start	0	7
Accumulation command	0	10
Clear the last accumulated data	0	11
Emergency stop	0	12
Undefined	0	13
Accumulation clear	0	14
All brand accumulation clear	0	15
Error reset	0	21
Print command	0	22
Net display	0	23
Gross display	0	24

Set value of reading out (Writing/reading selection = Reading [OFF])

Setting value or command order	Command No. (RwwnE)	General data area (RWrnC~RWrnD)
Undefined	1	
Undefined	2	
Undefined	3	
Undefined	4	
Undefined	5	
Final /S1	6	
Free fall /S4	7	
Preliminary 1 /S3	8	
Preliminary 2 /S2	9	
Over	10	
Under	11	
Near zero	12	
Full	13	
Tare	14	
Supplementary time	15	
Waiting time for judge after supplementary flow	16	
Automatic free fall compensation	17	
Undefined	18	
Undefined	19	
Accumulation value (8 digits)	20	
Accumulation times	21	
Accumulation value Lower 10 digits (32 bit)	22	
Accumulation value Upper 10 digits (32 bit)	23	
Brand code	32	
Undefined	57	
Undefined	60	
Undefined	61	
Undefined	62	
Undefined	63	
Undefined	64	
Undefined	65	
Undefined	66	
Undefined	67	
Undefined	68	
Undefined	69	
Confirmation of ZERO, SPAN (stability)	9006	

(4) Remote register (Instrument→Master)

4 stations occupied			
Station	Remote register	Contents	Remarks
1	RWr _n	(1) Net value	
	RWr _{n+1}		
	RWr _{n+2}	(2) Gross value	
	RWr _{n+3}		
2	RWr _{n+4}	(3) Accumulation value	
	RWr _{n+5}		
	RWr _{n+6}	(4) Error code	
	RWr _{n+7}	(5) Error assistance code	
3	RWr _{n+8}	(10) Brand code	
	RWr _{n+9}	Undefined	
	RWr _{n+A}		
	RWr _{n+B}		
4	RWr _{n+C}	(6) General data area	
	RWr _{n+D}		
	RWr _{n+E}	(7) Command No. (Response)	
	RWr _{n+F}	(8) Operation mode (Response)	

n : Value decided by setting of station No.

2 stations occupied			
Station	Remote register	Contents	Remarks
1	RWr _n	(9) Indicate value (Net value/Gross value)	
	RWr _{n+1}		
	RWr _{n+2}	(4) Error code	
	RWr _{n+3}	(5) Error assistance code	
2	RWr _{n+4}	(6) General data area	
	RWr _{n+5}		
	RWr _{n+6}	(7) Command No.(Response)	
	RWr _{n+7}	(8) Operation mode(Response)	

n : Value decided by setting of station No.

1 station occupied			
Station	Remote register	Contents	Remarks
1	RWr _n	(9) Indicate value (Net value/Gross value)	
	RWr _{n+1}		
	RWr _{n+2}	(4) Error code	
	RWr _{n+3}	(5) Error assistance code	

n : Value decided by setting of station No.

1) Net value (4 stations)

Area for displaying the net value

Data type : 32 bit binary with sign

Setting range : -999999 ~ 999999

2) Gross value (4 stations)

Area for displaying the gross value

Data type : 32 bit binary with sign

Setting range : -999999 ~ 999999

3) Accumulation value (4 stations)

Area for displaying the accumulation value

Data type : 32 bit binary with sign

Setting range : -19999999 ~ 99999999

4) Error code (4 stations, 2 stations, 1 station)

Area for displaying the error generating in the main body of the indicator

Refer to below table of error assistance code too.

Data type : 16 bits binary

Setting range : 0 ~ 255

5) Error assistance code (4 stations, 2 stations, 1 station)

Area for displaying the error No. generating in the main body of the indicator

Data type : 16 bits binary

Setting range : 0 ~ 255

Error code	Error assistance code	Contents
0	0	No error
1 (Weighing sequence error)	1	SQERR 0 : When measurement is stopped by inputting the Emergency stop while weighing.
	3	SQEER 2 : When the load value is under even if the supplementary flow is executed.
	4	SQEER 3 : When there is contradiction in the amount of the comparison value.
	5	SQEER 4 : When the batching time exceeds the limited time.
	6	SQERR 5 : When the discharging time exceeds the limited time.
	7	SQERR 6 : When the gross value < Final in discharge control.
	8	SQERR 7 : When the net value > fixed value in the start.
	10	SQERR 9 : When ON of ZERO BAND is an error in the batch start.
2 (Zero set error)	1	Zero set error In case of execute ZERO out of range of zero
	2	A/Z error In case of execute TARE out of range of tare.
3 (Other error)	3	A/D conversion error.
	31	EEPROM writing error.
	32	EEPROM reading error.
	99	Except for the measurement mode.
4 (Calibration error)	0	TE-L error
	1	TE-H error
	2	SP-L error
	3	SP-H error
99 (Setting error)	0	Receiving undefined command When undefined data is set at command No.
	1	Error outside the setting range
	2	Read-only state When accepting the calibration command except the measurement mode. When accepting the calibration command not to follow in the order of calibration. When exchanging the brand code in sequential control.



Refer to Error display in main body instruction manual about the contents of Error code.

6) General data area (4 stations, 2 stations)

When the set value reading out command is ordered by using the general command request (Request 2), this area represents the set value.

Data type : 32 bit binary with sign

7) Command No. (Response) (4 stations, 2 stations)

When the command order is executed by the general command request (Request 2), this area represents that command No.

Data type : 8 bit binary

8) Operation mode (Response) (4 stations, 2 stations)

When the operation mode is changed by the operation mode changeover request (request 3), this area represents that command No.

This function is prepared for future expansion.

Data type : 8 bit binary

9) Indicate value (Net value/Gross value) (2 stations, 1 station)

It is area which showing the Net value or Gross value by specified bit.

Data type : 32 bit binary with sign

Setting range : -999999 ~ 999999

10) Brand code (4 stations)

This area shows brand code.

Data type : 8 bit binary with sign

Setting range : 0 ~ 7

5-2-2. Relay zone

(1) Remote output (Master → Instrument)

4 stations occupied				
Device No.	Contents		Classification	
RYn0	(1)Setting value writing request (Request 1)		Communication	
RYn1				
RYn2	(2)General command request (Request 2)			
RYn3	(3)Selection of writing/Reading out. (R/W)			
RYn4	(4)Operation mode changeover request (Request 3)			
RYn5				
RYn6				
RYn7				
RYn8				
RYn9				
RYnA				
RYnB				
RYnC				
RYnD				
RYnE				
RYnF				
RY(n+1)0	(5)Zero		Control signal	
RY(n+1)1	(6)Zero clear			
RY(n+1)2	(7)Tare			
RY(n+1)3	(8)Tare clear			
RY(n+1)4	(9)Hold			
RY(n+1)5	(10)Net display			
RY(n+1)6	(11)Gross display			
RY(n+1)7				
RY(n+1)8	(12)Accumulation signal			
RY(n+1)9	(13)Accumulation clear			
RY(n+1)A	(14)Error cancellation request flag			
RY(n+1)B				
RY(n+1)C				
RY(n+1)D				
RY(n+1)E				
RY(n+1)F				
RY(n+2)0	(18)Brand code	10 ⁴	1	
RY(n+2)1			2	
RY(n+2)2			4	
RY(n+2)3				
RY(n+2)4				
RY(n+2)5				
RY(n+2)6				
RY(n+2)7				
~				
RY(n+7)0	System reservation zone			
RY(n+7)1				
RY(n+7)2				
RY(n+7)3				
RY(n+7)4				
RY(n+7)5				
RY(n+7)6				
RY(n+7)7				
RY(n+7)8				
RY(n+7)9	(15)Initialed data setting request flag			
RY(n+7)A	(16)Error reset requesting flag			
RY(n+7)B				
RY(n+7)C				
RY(n+7)D				
RY(n+7)E				
RY(n+7)F				

n : Value decided by setting of station No.

2 stations occupied			
Device No.	Contents		Classification
RYn0	(1)Setting value writing request (Request 1)		Communication
RYn1			
RYn2	(2)General command request (Request 2)		
RYn3	(3)Selection of writing/Reading out. (R/W)		
RYn4	(4)Operation mode changeover request (Request 3)		
RYn5			
RYn6			
RYn7			
RYn8			
RYn9			
RYnA			
RYnB			
RYnC			
RYnD			
RYnE			
RYnF			
RY(n+1)0	(5)Zero		Control signal
RY(n+1)1	(6)Zero clear		
RY(n+1)2	(7)Tare		
RY(n+1)3	(8)Tare clear		
RY(n+1)4	(9)Hold		
RY(n+1)5	(10)Net display		
RY(n+1)6	(11)Gross display		
RY(n+1)7			
RY(n+1)8	(12)Accumulation signal		
RY(n+1)9	(13)Accumulation clear		
RY(n+1)A	(14)Error cancellation request flag		
RY(n+1)B			
RY(n+1)C			
RY(n+1)D			
RY(n+1)E			
RY(n+1)F	(17)Indicate value changeover flag (Net value/ Gross value)		
RY(n+2)0	(18)Brand code	10 ⁴	
RY(n+2)1			2
RY(n+2)2			4
RY(n+2)3			
RY(n+2)4			
RY(n+2)5			
RY(n+2)6			
RY(n+2)7			
~			
RY(n+3)0	System reservation zone		
RY(n+3)1			
RY(n+3)2			
RY(n+3)3			
RY(n+3)4			
RY(n+3)5			
RY(n+3)6			
RY(n+3)7			
RY(n+3)8			
RY(n+3)9	(15)Initialed data setting request flag		
RY(n+3)A	(16)Error reset requesting flag		
RY(n+3)B			
RY(n+3)C			
RY(n+3)D			
RY(n+3)E			
RY(n+3)F			

n : Value decided by setting of station No.

1 station occupied					
Device No.	Contents			Classification	
RYn0	(5)Zero			Control signal	
RYn1	(6)Zero clear				
RYn2	(7)Tare				
RYn3	(8)Tare clear				
RYn4	(9)Hold				
RYn5	(12)Accumulation signal				
RYn6	(13)Accumulation clear				
RYn7	(17)Indicate value changeover flag (Net value/ Gross value)				
RYn8	(18)Brand code	10 ⁴	1		
RYn9			2		
RYnA			4		
RYnB					
RYnC					
RYnD					
RYnE					
RYnF					
RY(n+1)0	System reservation zone				
RY(n+1)1					
RY(n+1)2					
RY(n+1)3					
RY(n+1)4					
RY(n+1)5					
RY(n+1)6					
RY(n+1)7					
RY(n+1)8					
RY(n+1)9	(15)Initialed data setting request flag				
RY(n+1)A	(16)Error reset requesting flag				
RY(n+1)B					
RY(n+1)C					
RY(n+1)D					
RY(n+1)E					
RY(n+1)F					

n : Value decided by setting of station No.

※ Error reset is operated by main body side because Error cancellation request flag is not defined when 1 occupied station

(Synchronize with reset of the main body)

1) Setting value writing request (Request 1)

Writing of the data set in special data area (RWwn0~RWwnB) is requested.

- ON : In the request of writing
- OFF : After confirming "Setting value writing response (Response 1)".

2) General command request (Request 2)

Writing or reading out is requested by the command order.

Use with selection of writing or reading out (R/W) at the same time.

- ON : In the request of writing/reading out
- OFF : After confirming "Setting value writing response (Response 2)".

3) Selection of writing or reading out(R/W)

Writing or reading out is selected by the command order.

Writing the data set in General data area (RWwnC ~ RWwnD) is ordered for writing by command No. (RWwnE).

Reading out the data set in General data area (RWrnC ~ RWrnD) is ordered for reading out by command No. (RWwnE).

- ON : Reading out
- OFF : Writing

4) Operation mode changeover request (Request 3)

Writing of the data set in operation mode (RWwnF) is requested.

This function is prepared for future expansion.

- ON : In the request of writing request.
- OFF : After confirming "Operation mode changeover response (Response 3)"

5) Zero

Zero set is executed.

- ON : In requesting the execution of Zero set. (Operated by OFF→ON)
- OFF : Normal

6) Zero clear

Zero clear is executed.

- ON : In requesting the execution of Zero clear. (Operated by OFF→ON)
- OFF : Normal

7) Tare

Tare is executed.

- ON : In requesting the execution of Tare. (Operated by OFF→ON)
- OFF : Normal

8) Tare clear

Tare clear is executed.

- ON : In requesting the execution of Tare clear. (Operated by OFF→ON)
- OFF : Normal

9) Hold

A measurement value of the display is maintained.

- ON : Hold display (Level input)
- OFF : Hold release

10) Net display

The display is changed to Net value.

- ON : In requesting the execution of Net display. (Operated by OFF→ON)
- OFF : Normal

11) Gross display

The display is changed to Gross value.

- ON : In requesting the execution of Gross display. (Operated by OFF→ON)
- OFF : Normal

12) Accumulation signal

Accumulation is executed.

- ON : Turning on the Accumulation signal. (Operated by OFF→ON)
- OFF : Normal

13) Accumulation clear

Accumulation clear is executed.

- ON : In requesting the execution of Accumulation clear. (Operated by OFF→ON)
- OFF : Normal

14) Error cancellation request flag

Sequence error, Zero set error, A/Z error is canceled with Error condition flag.

And Error code is cleared to "0".

- ON : In requesting the execution of Error cancellation. (Operated by OFF→ON)
- OFF : Normal

15) Initialed data setting request flag

This instrument is not supported.

- ON : In the requesting initialization.
- OFF : Normal

16) Error reset requesting flag

Error reset is requested when the occurrent error is notified with Error condition flag (RX(n+7)A).

- ON : In the requesting of clear (Operated by OFF→ON)
- OFF : Normal

17) Indicate value NET value/GROSS value command

Indication value set in remote resistor area is selected as follows, when the station occupied 1 or 2.

- ON : Net value (Same as Net value of remote resistor when 4 stations occupied.)
- OFF : Gross value (Same as Gross value of remote resistor when 4 stations occupied.)

18) Brand code

Set the brand code by BCD code.

If you change the brand code by using CC-Link, set the function F-51 to [2].

If you change the brand code during the sequence, error code 99 and error assistance code 2 occurs.

(2) Remote input (Instrument → Master)

4 stations occupied			
Device No.	Contents		Classification
RXn0	(1) Setting value writing response (Response 1)		Communication
RXn1			
RXn2	General command response (Response 2)		
RXn3	Writing/reading out selection response (R/W response)		
RXn4	(4) Operation mode changeover response (Response 3)		
RXn5			
RXn6	(5) CPU normal operation		
RXn7			
RXn8	(6) Decimal point position 1		
RXn9	(6) Decimal point position 2		
RXnA	(6) Decimal point position 4		
RXnB			
RXnC			
RXnD			
RXnE			
RXnF			
RX(n+1)0	(7) Near Zero		Control signal
RX(n+1)1	(7) F.Flow/S1		
RX(n+1)2	(7) M.Flow/S2		
RX(n+1)3	(7) D.Flow/S3		
RX(n+1)4	(7) Over/S4		
RX(n+1)5	(7) OK/S0		
RX(n+1)6	(7) Under		
RX(n+1)7	(7) Stable		
RX(n+1)8	(7) Finish		
RX(n+1)9	(7) Weighing value over		
RX(n+1)A	(7) During hold		
RX(n+1)B	(7) Full		
RX(n+1)C			
RX(n+1)D	(10) Discharge (Gate open)		
RX(n+1)E	(11) Sequence error		
RX(n+1)F	(12) Abnormal weight		
RX(n+2)0	(18) Brand code	10 ⁴	1
RX(n+2)1			2
RX(n+2)2			4
RX(n+2)3			
RX(n+2)4			
RX(n+2)5			
RX(n+2)6			
RX(n+2)7			
~			
RX(n+7)0	System reservation zone		
RX(n+7)1			
RX(n+7)2			
RX(n+7)3			
RX(n+7)4			
RX(n+7)5			
RX(n+7)6			
RX(n+7)7			
RX(n+7)8			
RX(n+7)9	(13) Initialed data setting complete flag		
RX(n+7)A	(14) Error condition flag		
RX(n+7)B	(15) Remote READY		
RX(n+7)C			
RX(n+7)D			
RX(n+7)E			
RX(n+7)F			

n : Value decided by setting of station No.

※Abnormal weight is turned on by the error except the measurement sequence.

2 stations occupied				
Device No.	Contents			Classification
RXn0	(1) Setting value writing request (Response 1)			Communication
RXn1				
RXn2	(2) General command response (Response 2)			
RXn3	(3) Writing/reading out selection response (R/W response)			
RXn4	(4) Operation mode changeover response (Response 3)			
RXn5				
RXn6	(5) CPU normal operation			
RXn7				
RXn8	(6) Decimal point position 1			
RXn9	(6) Decimal point position 2			
RXnA	(6) Decimal point position 4			
RXnB				
RXnC				
RXnD				
RXnE				
RXnF				
RX(n+1)0	(7) Near Zero			Control signal
RX(n+1)1	(7) F.Flow/S1			
RX(n+1)2	(7) M.Flow/S2			
RX(n+1)3	(7) D.Flow/S3			
RX(n+1)4	(7) Over/S4			
RX(n+1)5	(7) OK/S0			
RX(n+1)6	(7) Under			
RX(n+1)7	(7) Stable			
RX(n+1)8	(7) Finish			
RX(n+1)9	(8) Weighing value over			
RX(n+1)A	(9) During hold			
RX(n+1)B	(7) Full			
RX(n+1)C				
RX(n+1)D	(10) Discharge (Gate open)			
RX(n+1)E	(11) Sequence error			
RX(n+1)F	(12) Abnormal weight			
RX(n+2)0				
RX(n+2)1	(18) Brand code	10 ⁴	1	
RX(n+2)2			2	
RX(n+2)3			4	
RX(n+2)4				
RX(n+2)5				
RX(n+2)6				
RX(n+2)7				
~				
RX(n+3)0	System reservation zone			
RX(n+3)1				
RX(n+3)2				
RX(n+3)3				
RX(n+3)4				
RX(n+3)5				
RX(n+3)6				
RX(n+3)7				
RX(n+3)8				
RX(n+3)9	(13) Initialed data setting complete flag			
RX(n+3)A	(14) Error condition flag			
RX(n+3)B	(15) Remote READY			
RX(n+3)C				
RX(n+3)D				
RX(n+3)E				
RX(n+3)F				

n : Value decided by setting of station No.

※Abnormal weight is turned on by the error except the measurement sequence.

1 station occupied		
Device No.	Contents	Classification
RXn0	(7) Near Zero	Control signal
RXn1	(7) F.Flow/S1	
RXn2	(7) M.Flow/S2	
RXn3	(7) D.Flow/S3	
RXn4	(7) Over/S4	
RXn5	(7) OK/S0	
RXn6	(7) Under	
RXn7	(7) Stable	
RXn8	(7) Finish	
RXn9	(8) Weighing value over	
RXnA	(9) During hold	
RXnB	(7) Full	
RXnC		
RXnD	(10) Discharge (Gate open)	
RXnE	(11) Sequence error	
RXnF	(12) Abnormal weight	
RX(n+1)0	System reservation zone	
RX(n+1)1		
RX(n+1)2		
RX(n+1)3		
RX(n+1)4		
RX(n+1)5		
RX(n+1)6		
RX(n+1)7		
RX(n+1)8		
RX(n+1)9	(13) Initialed data setting complete flag	
RX(n+1)A	(14) Error condition flag	
RX(n+1)B	(15) Remote READY	
RX(n+1)C		
RX(n+1)D		
RX(n+1)E		
RX(n+1)F		

n : Value decided by setting of station No.

※Abnormal weight is turned on by the error except the measurement sequence.

1) Setting value writing response (Response 1)

The end of writing by the Setting value writing request (request 1) is notified.

- ON : In completion of writing
- OFF : After confirming OFF of Setting value writing request. (Request 1)

2) General command response (Response 2)

The end of the command order by the General command request (request 2) is notified.

- ON : In the completion of command order
- OFF : After confirming OFF of the General command request (Request 2)

3) Writing/Reading out selection response (R/W response)

The status of write/reading out is notified by command order when the General command response (Response 2) is notified.

- ON : Reading out
- OFF : Writing

4) Operation mode changeover response (Response 3)

The end of changing operation mode by the Operation mode changeover request (Request 3) is notified.

- ON : In the completion of the changeover
- OFF : After confirming the OFF of the Operation mode changeover request (Request 3)

5) CPU normal operation

CC-Link interface operating normally is notified.

ON→OFF→ON reversing is notified at 0.5 seconds intervals

6) Decimal point position 1, 2, 4

The Decimal point position of the load value is notified by the 3 bits binary.

Position	Decimal point position 1	Decimal point position 2	Decimal point position 4
None	OFF	OFF	OFF
1	ON	OFF	OFF
2	OFF	ON	OFF
3	ON	ON	OFF
4	OFF	OFF	ON

7) Near Zero, and the other status

Statuses of Near Zero, F.Flow/S1, M.Flow/S2, D.Flow/S3, Over/S4, OK/S0, Under, Stable, Finish, and Full are notified.

8) Weighing value over

The occurrence of abnormal status (OL, OVF, -OL, -OVF) is notified when the status is over range.

- ON : In the occurrence of abnormal status
- OFF : Normal

9) During hold

The status of the display is notified.

- ON : During hold
- OFF : Free running

10) Discharge (Gate open)

The Discharge is notified.

- ON : During discharge
- OFF : Normal

11) Sequence error

The occurrence of Sequence error is notified.

- ON : In the occurrence of Sequence error
- OFF : Normal

12) Abnormal weight

Weighing value over or Zero set error are notified.

- ON : In the occurrence of abnormal status
- OFF : Normal

13) Initialed data setting complete flag

This instrument is not supported.

- ON : In the completion of initialization
- OFF : Normal

14) Error condition flag

The occurrence of the error in the indicator is notified.

- ON : In the occurrence of the error.
- OFF : Normal

15) Remote READY

Being able to complete initialization and to communicate is notified.

- ON : Possible to communicate
- OFF : In the initialization

16) Brand code

Always output the brand code by BCD code.

6. Function of calibration

When 4(four) and 2(two) stations are occupied, the calibration by the CC-Link interface is possible by using the general command request (Request 2). In this calibration, please set according to the following flow charts.

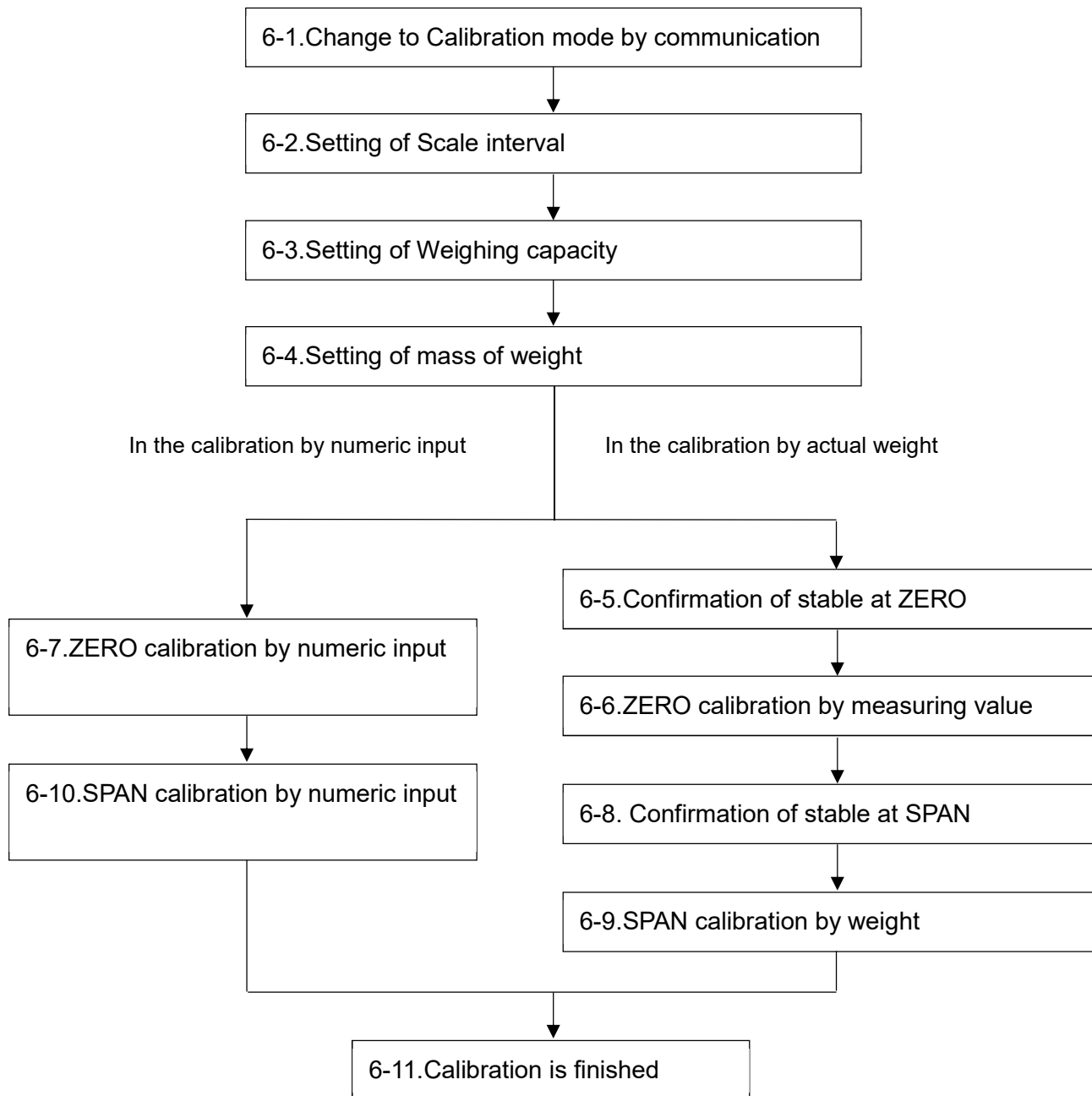

- CSD-903B displays [-RS-] during the calibration by communication.
- Please refer [5-2-1. (4) 5] Error assistance code] for the details of error code for the calibration by communication.
- When the calibration is compulsorily finished, all the data returns to the condition before the calibration without executing the registration.
- Please register the data for the calibration with the weight after confirming the stable condition without fail.

6-1. Change to Calibration mode by communication

Shift to the calibration mode after writing the data showing below.

(Error code: 99, Error assistance code: 1)

Command No. (RWwnE): 4 stations are occupied (RWwn6): 2 stations are occupied	General data area (RWwnC~RWwnD): 4 stations are occupied (RWwn4~RWwn5): 2 stations are occupied
9001	0

Error that cannot be executed

The following code is set when executing by other than the measurement mode.

Condition	Error code	Error assistance code
Condition that cannot be executed	99	2

6-2. Setting of scale interval

Command No. (RWwnE): 4 stations are occupied (RWwn6): 2 stations are occupied	General data area (RWwnC~RWwnD): 4 stations are occupied (RWwn4~RWwn5): 2 stations are occupied	
9002	Scale interval	Setting value
	1	1
	2	2
	5	5
	10	10
	20	20
	50	50

Error outside the setting range

When the data outside the setting range is written, the following code is set.

Condition	Error code	Error assistance code
Setting range error	99	1

Error that cannot be executed

The following code is set when executing by other than the calibration mode, or not setting it according to the flow chart in [6].

Condition	Error code	Error assistance code
Condition that cannot be executed	99	2

6-3. Setting of weighing capacity

The maximum display value is set by writing the data in the table below

Command No. (RWwnE): 4 stations are occupied (RWwn6): 2 stations are occupied	General data area (RWwnC~RWwnD): 4 stations are occupied (RWwn4~RWwn5): 2 stations are occupied
9003	Setting range : 1~99999

Error outside the setting range

When the data outside the setting range is written, the following code is set.

Condition	Error code	Error assistance code
Setting range error	99	1

Error that cannot be executed

The following code is set when executing by other than the calibration mode, or not setting it according to the flow chart in [6].

Condition	Error code	Error assistance code
Condition that cannot be executed	99	2

6-4. Setting of mass of weight

The mass of weight is set by writing the data in the table below.

Command No. (RWwnE): 4 stations are occupied (RWwn6): 2 stations are occupied	General data area (RWwnC~RWwnD): 4 stations are occupied (RWwn4~RWwn5): 2 stations are occupied
9004	Setting range : 1 ~ 99999 However, below the maximum display value.

Error outside the setting range

When the data outside the setting range is written, the following code is set.

Condition	Error code	Error assistance code
Setting range error	99	1

Error that cannot be executed

The following code is set when executing by other than the calibration mode, or not setting it according to the flow chart in [6].

Condition	Error code	Error assistance code
Condition that cannot be executed	99	2

6-5. Confirmation of ZERO stability

The condition of STABLE/UNSTABLE is reading out after setting the data in the table below.

Command No. (RWwnE): 4 stations are occupied (RWwn6): 2 stations are occupied	General data area (RWwnC~RWwnD): 4 stations are occupied (RWwn4~RWwn5): 2 stations are occupied
9006	Optional

The condition of STABLE/UNSTABLE read out is set in the table below.

Command No. (RWwnE): 4 stations are occupied (RWwn6): 2 stations are occupied	General data area (RWwnC~RWwnD): 4 stations are occupied (RWwn4~RWwn5): 2 stations are occupied
9006	0 : UNSTABLE 1 : STABLE

Error that cannot be executed

The following code is set when executing by other than the calibration mode.

Condition	Error code	Error assistance code
Condition that cannot be executed	99	2

6-6. ZERO calibration by weight

The load cell output value is registered as ZERO after writing the data in the table below.

When the data other than [0] are written in the general data area, the signal becomes an error outside a set range.

(Error code: 99, Error assistance code: 1)

Command No. (RWwnE): 4 stations are occupied (RWwn6): 2 stations are occupied	General data area (RWwnC~RWwnD): 4 stations are occupied (RWwn4~RWwn5): 2 stations are occupied
9007	0

TE-L error

When the read load cell output value is less than -2.5 mV/V and exceeds the range of zero adjustment range on a minus side, the following code is set.

Condition	Error code	Error assistance code
TE-L error	4	0

TE-H error

When the read load cell output value is more than 2.5 mV/V and exceeds the range of zero adjustment on a plus side, the following code is set.

Condition	Error code	Error assistance code
TE-H error	4	1

Error that cannot be executed

The following code is set when executing by other than the calibration mode, or not setting it according to the flow chart in [6].

Condition	Error code	Error assistance code
Condition that cannot be executed	99	2

6-7. ZERO calibration by numeric input

The load cell output value is registered as ZERO after writing the data in the table below

Command No. (RWwnE): 4 stations are occupied (RWwn6): 2 stations are occupied	General data area (RWwnC~RWwnD): 4 stations are occupied (RWwn4~RWwn5): 2 stations are occupied
9008	Setting range : -25000 ~ 25000 (-2.5 mV/V ~ 2.5 mV/V)

TE-L error

When the read load cell output value is less than -2.5 mV/V and exceeds the range of zero adjustment range on a minus side, the following code is set.

Condition	Error code	Error assistance code
TE-L error	4	0

TE-H error

When the read load cell output value is more than 2.5 mV/V and exceeds the range of zero adjustment range on a plus side, the following code is set.

Condition	Error code	Error assistance code
TE-H error	4	1

Error that cannot be executed

The following code is set when executing by other than the calibration mode, or not setting it according to the flow chart in [6].

Condition	Error code	Error assistance code
Condition that cannot be executed	99	2

6-8. Confirmation of SPAN stability

*Please execute in the same manner of [Confirmation of ZERO stability].

The condition of STABLE/UNSTABLE is reading out after setting the data in the table below.

Command No. (RWwnE): 4 stations are occupied (RWwn6): 2 stations are occupied	General data area (RWwnC~RWwnD): 4 stations are occupied (RWwn4~RWwn5): 2 stations are occupied
9006	Optional

The condition of STABLE/UNSTABLE read out is set in the table below.

Command No. (RWwnE): 4 stations are occupied (RWwn6): 2 stations are occupied	General data area (RWwnC~RWwnD): 4 stations are occupied (RWwn4~RWwn5): 2 stations are occupied
9006	0 : UNSTABLE 1 : STABLE

Error that cannot be executed

The following code is set when executing by other than the calibration mode.

Condition	Error code	Error assistance code
Condition that cannot be executed	99	2

6-9. SPAN calibration by weight

The load cell output value is registered as a SPAN by writing the data in the table below.

When the data other than [0] are written in the general data area, the signal becomes an error outside a set range.

(Error code: 99, Error assistance code: 1)

Command No. (RWwnE): 4 stations are occupied (RWwn6): 2 stations are occupied	General data area (RWwnC~RWwnD): 4 stations are occupied (RWwn4~RWwn5): 2 stations are occupied
9010	0

SP-L error

When the read load cell output value is below 0 mV/V and exceeds over SPAN adjustment range at minus side, the following code is set.

Condition	Error code	Error assistance code
SP-L error	4	2

SP-H error

When the read load cell output value is over 3.1 mV/V and exceeds over SPAN adjustment range at plus side, the following code is set.

Condition	Error code	Error assistance code
SP-H error	4	3

Error that cannot be executed

The following code is set when executing by other than the calibration mode, or not setting it according to the flow chart in [6].

Condition	Error code	Error assistance code
Condition that cannot be executed	99	2

6-10. SPAN calibration by numeric input

SPAN is registered by setting the numeric value with the unit of mV/V after writing the data in the table below

Command No. (RWwnE): 4 stations are occupied (RWwn6): 2 stations are occupied	General data area (RWwnC~RWwnD): 4 stations are occupied (RWwn4~RWwn5): 2 stations are occupied
9011	Setting range : 1 ~ 31000 (0.0001 mV/V ~ 3.1 mV/V)

SP-L error

When the read load cell output value is below 0 mV/V and exceeds over SPAN adjustment range at minus side, the following code is set.

Condition	Error code	Error assistance code
SP-L error	4	2

SP-H error

When the read load cell output value is over 3.1 mV/V and exceeds over SPAN adjustment range at plus side, the following code is set.

Condition	Error code	Error assistance code
SP-H error	4	3

Error that cannot be executed

The following code is set when executing by other than the calibration mode, or not setting it according to the flow chart in [6].

Condition	Error code	Error assistance code
Condition that cannot be executed	99	2

6-11. End of calibration

The calibration data of the ZERO/SPAN, etc., that is registered temporary is stored by writing the data in the table below.

When the data other than [0] are written in the general data area, the signal becomes an error outside a set range.

(Error code: 99, Error assistance code: 1)

Command No. (RWwnE): 4 stations are occupied (RWwn6): 2 stations are occupied	General data area (RWwnC~RWwnD): 4 stations are occupied (RWwn4~RWwn5): 2 stations are occupied
9099	0

Error that cannot be executed

The following code is set when executing by other than the calibration mode, or not setting it according to the flow chart in [6].

Condition	Error code	Error assistance code
Condition that cannot be executed	99	2



- After the release of calibration mode, CSD-903B becomes from all lighting to the state of measurement mode.
- Error code 3 and error assistance code 99 occur because all lighting means the states other than the measurement mode.

6-12. Calibration forced finish

During the calibration procedure, the calibration is discontinued without storing the calibration data that is registered temporarily by writing the data in the table below, and you can return to the measurement mode.

When the data other than [0] are written in the general data area, the signal becomes an error outside a set range. (Error code: 99, Error assistance code: 1)

Command No. (RWwnE): 4 stations are occupied (RWwn6): 2 stations are occupied	General data area (RWwnC~RWwnD): 4 stations are occupied (RWwn4~RWwn5): 2 stations are occupied
9000	0

Error that cannot be executed

The following code is set when executing by other than the calibration mode, or not setting it according to the flow chart in [6].

Condition	Error code	Error assistance code
Condition that cannot be executed	99	2



- After the release of calibration mode, CSD-903B becomes from all lighting to the state of measurement mode.
- Error code 3 and error assistance code 99 occur because all lighting means the states other than the measurement mode.

7. Operation method

7-1. Writing the set value

Setting value is written by “Setting value writing request (Request 1)” from the Master station.

The instrument recognizes that “Setting value writing request (Request 1) [RYn0]” is turned on, and it writes the data set in “Special data area [RWwn0~RWwn+9]” into the indicator.

It responds to the master station by “Setting value writing response (Response 1)” after writing is completed.

Timing chart

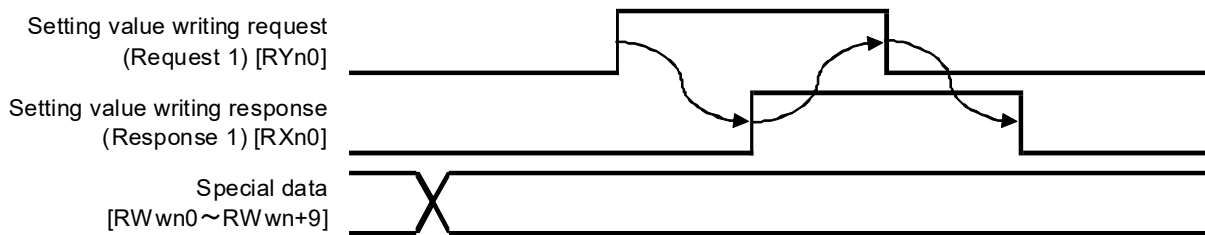

7-2. Writing/Reading by general command

Operation of the command order is executed by “General command request (Request 2) [RYn2]” from the Master station.

The instrument recognizes that “General command request (Request 2) [RYn2]” was turned on, and it executes to write the data set in “General data area [RWrn+C~D]” or to read the data into “General data area [RWrn+C~D]” to the instrument by “Selection of writing or reading out(R/W) [RYn3]” and “Command No. [RWwn+E]”.

It responds to the master station by “General command response (Response 2) [RXn2]” after writing is completed.

1) Writing request

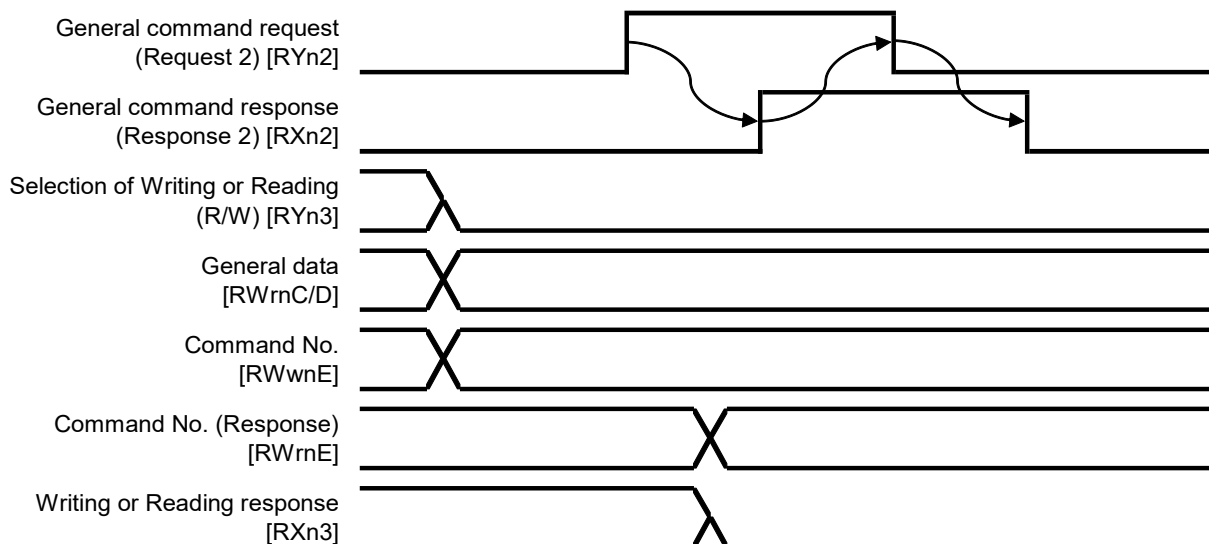

Please set the stored place to the internal RAM when the set value is continuously changed, and the rewritable time of EEPROM might exceed about one million times.

2) Reading out request

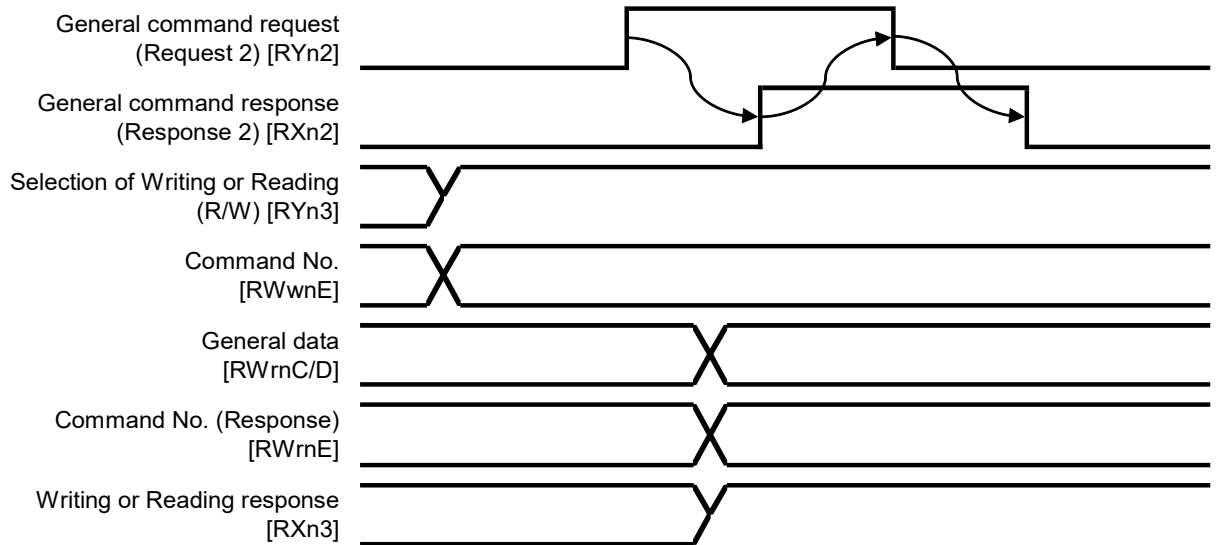

7-3. Shift to status where it is possible to communicate

Shifting to status where it is possible to communicate is notified after the power supply is turned on or Initial data setting is requested from the master station.

“Remote READY [RX(n+7)B]” is turned on along with the power supply turning on after initialization (set initialing) completion is done and it is assumed the status where it is possible to communicate.

Remote READY is turned off when “Initial data setting request [RY(n+7)9]” transmitted by the master station is turned on, and initialization is executed.

It responds to the master station after initialization is completed by turning on “Initial data setting completion [RX(n+7)9]”.

That the master station recognizes turning on “Initial data setting completion [RX(n+7)9]”, and “Initial data setting completion [RX(n+7)9]” is turned off makes that “Initial data setting request [RY(n+7)9]” is turned off, and remote READY is turned on.

Timing chart

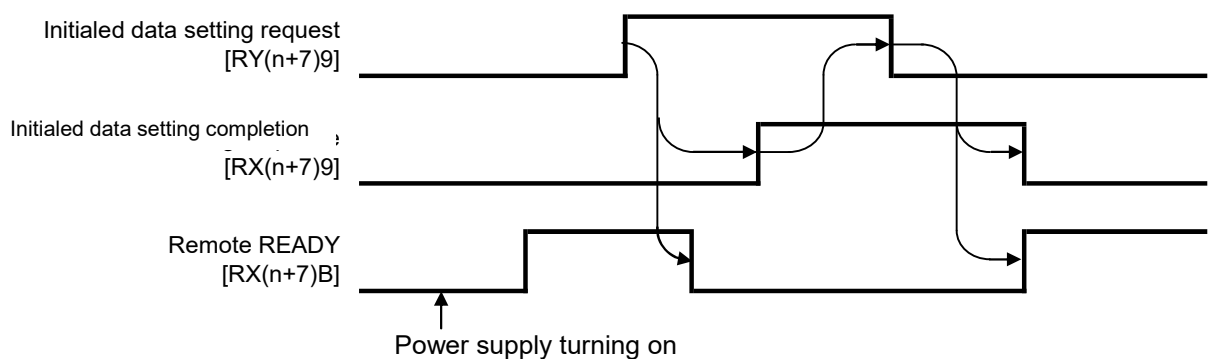

7-4. Error condition/Reset requesting flag

The status sequence when an error is detected and the reset sequence are shown.

The remote READY [RX(n+7)B] is turned off and the Error condition flag [RX(n+7)A] is turn on when an error is detected,

The Error condition flag [RX(n+7)A] is turn off when the Error reset requesting flag [RY(n+7)A] transmitted by the Master station is turned on.

Afterwards, the Remote READY [RX(n+7)B] is turn on when the error reset requesting flag [RY(n+7)A] transmitted by the master station is turned off.

When an error is detected, reset the error as the following sequence.

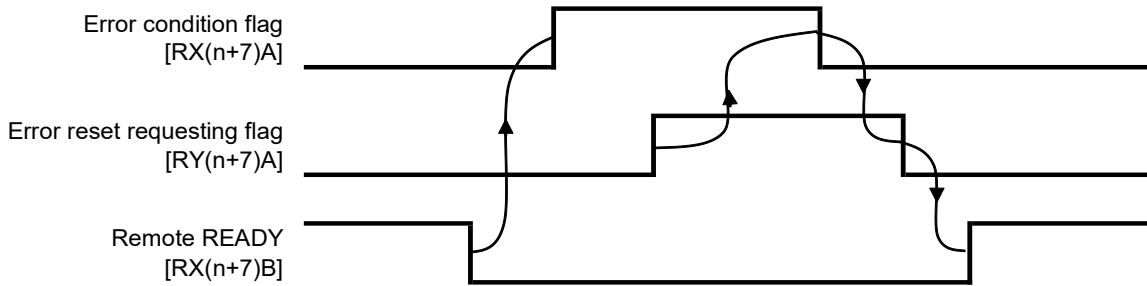

7-5. CPU normal operation signal

The instrument operating normally is notified to the Master station.

When the instrument operates normally, the condition of “CPU normal operating signal [RXn6]” is reversed at 0.5 seconds interval.

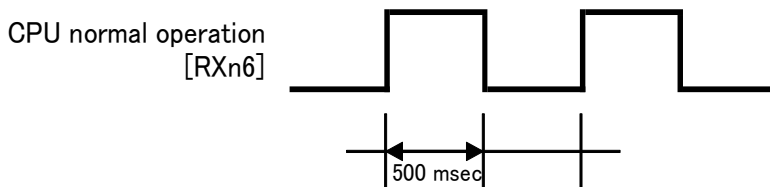

A temporary delay occurs in CPU normal operation signal while memorizing various set values and while executing memory clearness.

8. Specifications of interface

8-1. Specifications of CC-Link interface

Specifications	Contents
Version	Ver.1.10
The number of occupied stations	Selectable from 1, 2 or 4 stations.
Communication method	Polling method
Synchronous method	Bit synchronization method
Baud rate	Selectable from 156 k, 625 k, 2.5 M, 5 M and 10 Mbps
Transmission path form	RS-485 bus
Transmission format	HDLC conforming
Remote station number	In the case of 1 station occupied, No's.01 ~ 64 can be selectable. In the case of 2 stations occupied, No's.01 ~ 63 can be selectable. In the case of 4 stations occupied, No's.01 ~ 61 can be selectable.
Numbers of connection	In the case of 1 station occupied, 64 units at maximum. In the case of 2 stations occupied, 32 units at maximum. In the case of 4 stations occupied, 16units at maximum.
Termination	Resistance externally attached.
Status LED	[RUN], [ERR], [SD], [RD]

8-2. Accessories

CC-Link Instruction Manual	1 piece
CC-Link communication connector	1 piece (MSTB 2,5/5-ST-5,08 AU by PHOENIX CONTACT)