

Operating Instructions

Minebea Intec Combics

Models CAAPP.., CAAPS..
Painted or Stainless Steel Weighing Platforms



Contents

Explanation of the Symbols.....	2
Safety Instructions.....	2
Setting Up the Scale.....	3
Installation.....	6
Care and Maintenance.....	11
Disposal.....	12
Accessories.....	13
Declarations of Conformity.....	17

Explanation of the Symbols

The following symbols are used in these instructions:

- indicates steps you must perform
- indicates steps you must perform only under certain conditions
- > describes what happens after you have performed a certain step
- indicates an item in a list
-  indicates a hazard

Safety Instructions

Combics weighing platforms have been constructed in accordance with the European Directives as well as international regulations and standards for electrical equipment, electromagnetic compatibility and safety.

- Do not expose the weighing platform unnecessarily to aggressive chemical vapors or to extreme temperatures, moisture, shocks, or vibrations.
- Do not use a Combics weighing platform in a Zone 0, 1, or 20 hazardous area.
- With Option Y2 installed, you may operate any Combics weighing platform in a Zone 2 or 22 hazardous area.
- Avoid exposing the weighing platform to static electricity; be sure to connect the equipotential bonding conductor to the junction box.
- Observe the particular IP protection rating of your scale: IP65 protection rating for non-stainless steel models; IP67/69K protection rating for stainless steel models. First digit: rating 6 indicates resistance to penetration by dust particles of a specified size. Second digit: rating 5 indicates resistance to splashes of water as well as wash-down-resistance. Rating 7 indicates resistance to penetration by water during 30-minute immersion up to a depth of 1 meter (~3 ft). IP69K: protected against protection against penetration into the housing of water sprayed from any or all directions during high-pressure/steam cleaning. The particular IP protection rating for the weighing platforms is ensured only if the rubber gasket is installed on the junction box and all cable gland screw fasteners are tightened securely. Improper installation will result in the forfeiture of all claims under the manufacturer's warranty.
- The junction box may be opened only by authorized service technicians who have been trained by Minebea Intec and who follow Minebea Intec' standard operating procedures for maintenance and repair.
- If you see any indication that the weighing platform cannot be operated safely (for example, because of equipment damage), turn off the platform and lock it in a secure place so that it cannot be used for the time being.
- Suspension points are provided on platforms measuring 1000 × 1000 mm or larger. If you need to transport or lift the scale or load plate using a crane, do not step underneath the suspended scale or load plate. Be sure to observe the corresponding safety rules and regulations for the prevention of accidents. Do not damage the junction box or the load receptor during transportation.
- If you use suction lifting equipment to lift the load plate, always wear gloves, hard-toed safety boots and protective clothing. Warning: this procedure can cause personal injury! Therefore, only reliable staff who are qualified to perform such work are allowed to use suction lifting equipment.
- Always make sure the weighing platform is disconnected from AC power before performing any installation, cleaning, maintenance or repair work.
- Check the pin assignment if you use cables purchased from a different manufacturer. Before connecting such a cable to Minebea Intec equipment, check the pin assignment on the corresponding wiring diagram or chart and disconnect any wires that are identified differently from those specified by Minebea Intec. The operator shall be solely responsible for any damage or injuries that may occur when using cables not supplied by Minebea Intec.

Setting Up the Scale

- Read the operating instructions thoroughly before starting up the device.
- After unpacking the device, check it immediately for any visible external damage.
- The device is delivered from the factory with the height-adjustable feet set for an even surface. Improper handling of the scale can cause damage to components.



Weighing platform with lift-up load plate/Option T1

- Before lowering the load plate, use the key provided to ensure that the lock is in the correct position.

Lift Mechanism Options:

The pneumatic springs are pre-tensioned, which enables the platform to be set up with minimum manual exertion and, when unlocked, also means the platform will be angled at approx. 10–20° depending on the size.

- Once the load plate has been lowered, close the lock using the key.

Opening and Closing the Weighing Platform

Warning of crush danger

- ▷ The weighing platform should only be lifted up and down by trained personnel.
- ▷ Make sure that no one is standing in front of or under the load plate.
- ▷ The load plate should only be lifted from the side.



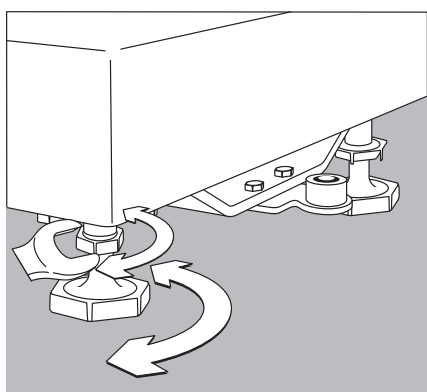
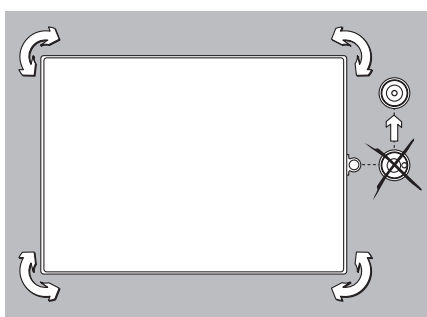
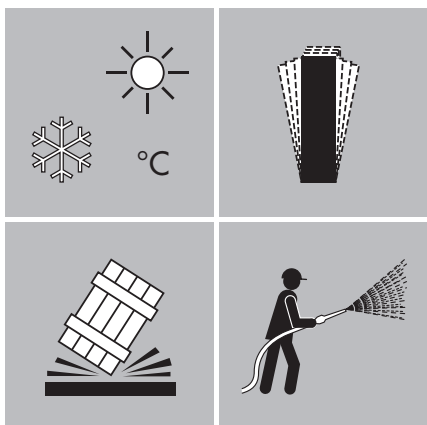

● Choose a suitable place to set up the weighing platform. This place should have a dry, horizontal and even surface. The operating temperature range is between -10°C and $+40^{\circ}\text{C}$ ($+14^{\circ}\text{F}$ and $+104^{\circ}\text{F}$). The allowable structural load-carrying capacity of the floor or surface must be sufficient to support both the weight of the weighing platform and its maximum weighing capacity.

If you need to use the weighing platform in areas exposed to heavy traffic (e.g., fork-lift trucks), you should install a protective frame, consisting of angular braces, around the weighing platform.

Do not expose the weighing platform unnecessarily to aggressive chemical vapors or to extreme temperatures, moisture, shocks, or vibrations, which could result in damage.

Note:

This equipment has been tested and found to comply with the limits for a Class A digital device, pursuant to Part 15 of the FCC rules. These limits are designed to provide reasonable protection against harmful interference when the equipment is operated in a commercial environment. This equipment generates, uses and can radiate radio frequency energy and, if not installed and used in accordance with the instruction manual, may cause harmful interference to radio communications.

Operation of this equipment in a residential area is likely to cause harmful interference in which case the user will be required to correct the interference at their own expense. Changes or modifications not expressly approved by Minebea Intec could void the user's authority to operate the equipment.

● The air bubble must be centered within the circle on the level indicator.

- Level the weighing platform using the leveling feet as described below:
- Check to ensure that all leveling feet rest securely on the work surface.
 - > Each of the leveling feet must support an equal load!
- Loosen the locknuts on the leveling feet using a 19-mm open-end wrench (spanner).
- > Adjusting the leveling feet:
 - To raise the weighing platform, extend the leveling feet (turn clockwise).
 - To lower the weighing platform, retract the leveling feet (turn counterclockwise).
- After leveling the weighing platform, retighten the locknuts securely as described below. Low-capacity platforms (1 load cell): tighten the locknuts against the platform frame; high-capacity platforms (4 load cells): tighten the locknuts against the platform feet.

● If the weighing platform with option Y2 is installed in a Zone 2 or 22 hazardous location, it must be grounded (i.e., an equipotential bonding conductor must be connected).

This should be done by a trained technician.

All Combics weighing platforms are equipped with a connector for the grounding conductor located either below the load plate, on the junction box, or on the base frame of the weighing platform. The position is marked in each case by the symbol shown here, indicating the grounding connection.

The grounding conductor is connected to a threaded bolt or terminal screw, or a bore hole is provided. If a drill hole is provided, use a stainless steel screw and nut to connect the grounding conductor. Use of a tooth lock washer is recommended, to prevent the screw from coming loose. The wire used for the grounding conductor must have a cross-sectional diameter of at least 4 mm², with a suitable ring lug attached.

Connect all equipment, including peripheral devices, to the equipotential bonding conductor.

Installation

- Connect the cable of the weighing platform to the indicator.

Note:

The cable gland along with the screw fasteners is already pre-assembled. Use extreme care when attaching or detaching a cable. Use a torque wrench and tighten the cable gland to 5 nm.

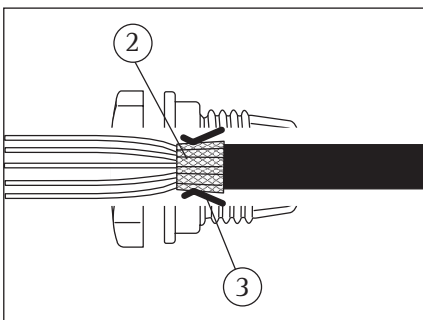
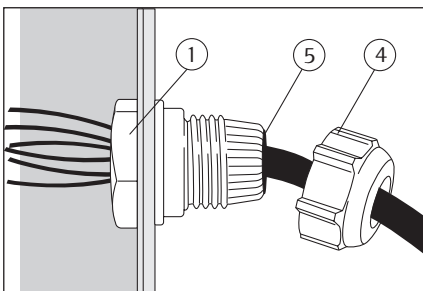

- Strip off the insulation at the cable end and attach the cable as follows:
 - Route the cable through the cable gland.
 - Properly tighten the screw fasteners of the cable gland.
 - Remove the casing from a section of the cable end (see illustration). The shield (1) must have contact with the clamps (2).
 - Expose approximately 15 cm (6 inches) of the wires (3) for installation.
 - Route the cable through the cable gland.
 - Make sure the shield is in contact with the clamps because the cable is grounded by the shield.

- Attach the cable to the weighing platform as follows:
 - Expose approximately 5 cm (2 inches) of the wires for installation.
 - Expose approximately 1 cm (1/2 inch) of the wires and attach ferrules to the wires.
 - Securely attach the wires to the screw terminals. (blue = positive, brown or black = negative)

Indicator Pin Assignment

NO.	Signal des.	Meaning	load cell*	load cell**
1	BR_POS	Bridge supply voltage +	blue	red
2	SENSE_POS	Sense +	green	white
3	OUT_POS	Measuring voltage +	white	green
4	OUT_NEG	Measuring voltage -	red	gray
5	SENS_NEG	Sense -	gray	black
6	BR_NRG	Bridge supply voltage -	black or brown	blue

* Load cell with gray cable.

** Load cell with green or black cable.

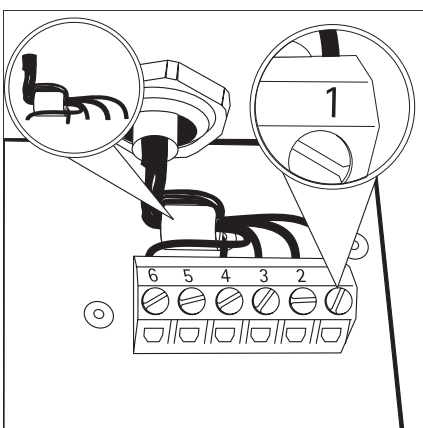

Color Codes of the Wiring for Weighing Platforms, Models CAAPP..

Platform size in mm	No.:	Wiring Diagram for the Indicator					
		1	2	3	4	5	6
320×240 (DC) ¹⁾		blue	green	white	red	gray	black or brown
320×240 (DC) ²⁾		red	white	green	gray	black	blue
400×300 (ED) ¹⁾		blue	green	white	red	gray	black or brown
400×300 (ED) ²⁾		red	white	green	gray	black	blue
500×400 (FE) ¹⁾		blue	green	white	red	gray	black or brown
500×400 (FE) ²⁾		red	white	green	gray	black	blue
650×500 (GF)		blue	green	white	red	gray	black or brown
800×600 (IG)		blue	green	white	red	gray	black or brown
800×800 (II)		blue	green	white	red	gray	black or brown
1000×800 (LI)		blue	green	white	red	gray	black or brown
1000×800 (LI) 300kg		red	white	green	gray	black	blue
1000×1000 (LL)		red	white	green	gray	black	blue
1250×1000 (NL)		blue	green	white	red	gray	black or brown
1250×1250 (NN)		red	white	green	gray	black	blue
1500×1250 (RN)		blue	green	white	red	gray	black or brown
1500×1500 (RR)		blue	green	white	red	gray	black or brown
2000×1500 (WR)		blue	green	white	red	gray	black or brown

¹⁾ HBM Load cell with gray cable ²⁾ NMB Load cell with green cable

Color Codes of the Wiring for Weighing Platforms, Models CAAPS., ...-L, ...-I, ...-BCE, ...-NCE

Platform size in mm	No.:	Wiring Diagram for the Indicator					
		1	2	3	4	5	6
320×240 (DC)		blue	green	white	red	gray	black or brown
400×300 (ED)		blue	green	white	red	gray	black or brown
500×400 (FE)		blue	green	white	red	gray	black or brown
650×500 (GF)		blue	green	white	red	gray	black or brown
800×600 (IG)		blue	green	white	red	gray	black or brown
800×800 (II)		blue	green	white	red	gray	black or brown
1000×800 (LI)		blue	green	white	red	gray	black or brown
1000×1000 (LL)		blue	green	white	red	gray	black or brown
1250×1000 (NL)		blue	green	white	red	gray	black or brown
1250×1250 (NN)		blue	green	white	red	gray	black or brown
1500×1250 (RN)		blue	green	white	red	gray	black or brown
1500×1500 (RR)		blue	green	white	red	gray	black or brown
2000×1500 (WR)		blue	green	white	red	gray	black or brown

Models CAAPS1-...-MCE, ...-UCE

Platform size in mm	No.:	Wiring Diagram for the Indicator					
		1	2	3	4	5	6
320×240 (DC)		green	blue	white	red	brown	black
400×300 (ED)		green	blue	white	red	brown	black
500×400 (FE)		green	blue	white	red	brown	black

Models CAAPS.. and option IP69 (IP69K)

Platform size in mm	No.:	Wiring Diagram for the Indicator					
		1	2	3	4	5	6
320×240 (DC)		red	white	green	gray	black	blue
400×300 (ED)		red	white	green	gray	black	blue
500×400 (FE)		red	white	green	gray	black	blue

Model codes

CAAP	S	4	–	3000	NN	–	I / S
Family name	Material	Number of Load cells		Weighing capacity See Chart 2	Dimensions		Resolution
CAAP*..	a	b		c	d		e
Combics Analog Platform	P = Steel S = Stainless steel	1 = One load cell 4 = Four load cells		in kg 3 6 15 30 60 150 300 600 1500 3000	See Chart 1		See Chart 2

- * CAAPP = IP65 Material: steel; powder-coated or galvanized
 CAAPS = IP67 Material: steel; designed and manufactured in accordance with EHEDG¹⁾ recommendations
 CAAPS with IP69 = IP69K Material: steel; with hermetically sealed load cell made of high-alloy stainless steel; designed and manufactured in accordance with EHEDG¹⁾ recommendations
 Special-order scale versions made of high-quality alloys available on request

¹⁾ European Hygienic Engineering Design Group

Chart 1, Specifications/Dimensions of Specific Models

Code	DC	ED	FE	GF	IG	II	LI	LL	NL	NN	RN	RR	WR
Width (mm)	240	300	400	500	600	800	800	1000	1000	1250	1250	1500	1500
Length (mm)	320	400	500	650	800	800	1000	1000	1250	1250	1500	1500	2000

Chart 2, Resolutions:

Resolution 1 weighing range

Resolution* 2 weighing ranges

CAAP..	-L	-I	-S	-BCE	-NCE			
Max capacity in kg	15,000 d in g	30,000 d in g	≥ 60,000 d in g	1 × 3,000 e in g	Weighing range 1 in kg	Resolution range 1 in g	Weighing range 2 in kg	Resolution range 2 in g
3	0.2	0.1	0.05	1	1.5	0.5	3	1
6	0.5	0.2	0.1	2	3	1	6	2
15	1	0.5	0.2	5	6	2	15	5
30	2	1	0,5	10	15	5	30	10
60	5	2	1	20	30	10	60	20
150	10	5	2	50	60	20	150	50
300	20	10	5	100	150	50	300	100
600	50	20		200	300	100	600	200
1500	100	50		500	600	200	1500	500
3000	200	100		1000	1500	500	3000	1000

2 × 3,000 e¹)²)3 × 3,000 e¹)²)6,000 e¹)²)

CAAPS.. Multi Interval -MCE					Multi Range -UCE						-RCE	
MAX capacity in kg	Weighing capacity 1 in kg	Resolution range 1 in g	Weighing capacity 2 in kg	Resolution range 2 in g	Weighing capacity 1 in kg	Resolution range 1 in g	Weighing capacity 2 in kg	Resolution range 2 in g	Weighing capacity 3 in kg	Resolution range 3 in g	Weighing capacity in kg	Resolution range in g
3	1.5	0.5	3	1	-	-	-	-	-	-	-	-
6	3	1	6	2	1.5	0.5	3	1	6	2	-	-
15	-	-	-	-	3	1	6	2	15	5	-	-
30	15	5	30	10	6	2	15	5	30	10	-	-
60	30	10	60	20	15	5	30	10	60	20	60	10
150	60	20	150	50	30	10	60	20	150	50	120	20
300	150	50	300	100	60	20	150	50	300	100	300	50
600	300	100	600	200	150	50	300	100	600	200	600	100
1500	600	200	1500	500	300	100	600	200	1500	600	1200	200
3000	1500	500	3000	1000	600	200	1500	500	3000	1000	3000	500

* The weighing ranges allowed in legal metrology are listed in the Declaration of Conformity. On scales with two weighing ranges (2 × 3,000 e), the scale does not automatically switch back to the higher resolution of the fine range once you use the second, higher-capacity range. In other words, the lower resolution of the higher range will be retained after taring.

1) IP69K not for all CAW*S4 models (see data sheet)

2) Depending on the model type (see data sheet)

Resolution (depending on the readability)

- L	15,000 d, intervals
- I	30,000 d, intervals
- S	≥ 60,000 d, intervals
- BCE	1 × 3,000 e, verifiable intervals
- NCE	2 × 3,000 e, verifiable intervals, multi-range, fixed fine range
- MCE	2 × 3,000 e, verifiable intervals, multi-interval, adjustable fine range
- UCE	3 × 3,000 e, verifiable intervals, multi-range, fixed fine range
- RCE	1 × 6,000 e, verifiable intervals

Operating Limits

You should not place loads on the scale that exceed its maximum weighing capacity. Depending on the position of the load (center, side, one-sided corner load), the maximum capacity of the weighing platform (in kg) is as follows:

Maximum capacity of the weighing platform:

Model	Center	Side	Corner
DC	50	35	20
ED	130	85	45
FE	300	200	100
GF (P*)	600	400	200
GF (S**)	450	300	150
IG (P*)	1200	800	400
IG (S**)	900	600	300
II	4500	3000	1500
LL	4500	3000	1500
NL	4500	3000	1500
NN	4500	3000	1500
RN	4500	3000	1500
RR	4500	3000	1500
WR	4500	3000	1500

* Steel

** Stainless steel

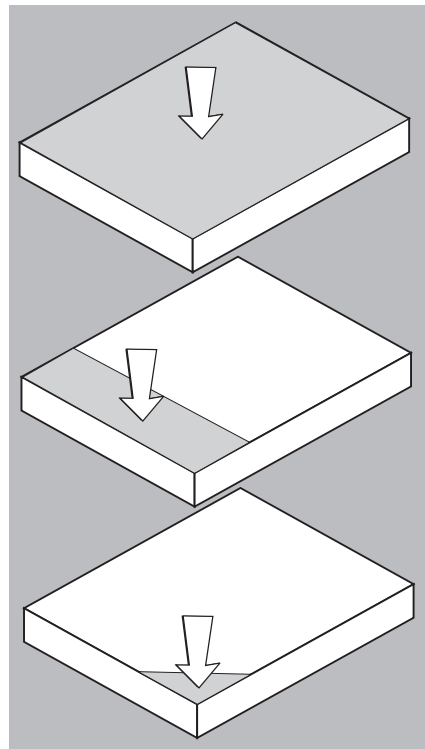

Cable lengths

Model code	DC	ED	FE	GF	IG	II	LL	NL	NN	RN	RR	WR
	2.5	2.5	2.5	3.0	3.0	6.0	6.0	6.0	6.0	6.0	6.0	6.0

Care and Maintenance

Cleaning

Minebea Intec platforms of the CAAPS.. series are designed in compliance with directives of the EHEDG (European Hygienic Equipment Design Group), in accordance with HACCP (Hazard Analysis and Critical Control Points) standards for prevention of contamination, which means they are particularly easy to clean and disinfect.

- Unplug the scale from the AC power before cleaning.
- To clean the weighing platform in a dry area, use a piece of cloth wet with a commercially available cleaning agent to wipe it down. Follow the manufacturer's instructions for the cleaning agent.
- ⚠ Never use concentrated acids, bases, solvents or pure alcohol to clean the weighing platform.
- To clean the weighing platform in a wet area, wash it down using a gentle stream of water (60°C max.) sprayed over the top of the load plate.
- ⚠ Do not use high-pressure cleaning equipment to clean the weighing platform.
- > If the water that you use to clean the weighing platform is too hot or too cold, the difference in temperature between the water and the weighing platform can cause condensation within the weighing platform. This condensation may cause the weighing platform to malfunction.
- If the scale is installed in a pit, make sure that no debris builds up between the pit and the platform to prevent weighing errors.
- Regularly remove debris from the bottom of the pit.

Cleaning the Interior of the Platform

- To clean the inside of the weighing platform, remove the load plate.
Be especially careful when removing the load plate from scales measuring 1000 × 1000 mm or larger.
- ⚠ Please follow the safety instructions.
- Use compressed air to blow debris out of the interior of the scale or flush it out using a gentle stream of water (60°C max.).
Be sure that no debris builds up in the gap between the load receptor and the fastening plate in order to prevent compromising the overload protection.

Cleaning Stainless Steel Surfaces

Clean all stainless steel parts regularly. Use a damp cloth or sponge to clean stainless steel parts on the weighing instrument. You can use any household cleaning agent that is suitable for use on stainless steel. Clean stainless steel surfaces by wiping them down. Then rinse the equipment thoroughly, making sure to remove all residues. Afterwards, allow the equipment to dry.

If desired, you can apply oil to the cleaned surfaces as additional protection.

- ⚠ Do not use stainless steel cleaning agents that contain soda lye (caustic), acetic acid, hydrochloric acid, sulfuric acid or citric acid.

Corrosive Environment

- Remove all traces of corrosive substances from the weighing platform on a regular basis.

Disposal

The packaging is to be taken to a local waste disposal site if no longer required. The packaging comprises environmentally-friendly materials that can be used as secondary raw materials. The device, including accessories and batteries, is not to be thrown into the household waste. EU legislation in Member States requires electrical and electronic equipment to be collected separately from unsorted municipal waste so that it may be recycled. In Germany and several other countries, Minebea Intec itself assumes responsibility for the return and conformant disposal of its electronic and electrical products. These products may not be placed with household waste or brought to collection centres run by local public disposal operations, not even by small commercial operators. For disposal in Germany and in the other member nations of the European Economic Area (EEA), please contact our local service technicians or our Service Centre in Germany:

Minebea Intec Bovenden GmbH & Co. KG
Leinetal 2, 37120 Bovenden, Germany
WEEE-Reg.-Nr. DE58091735

In countries that are not members of the European Economic Area (EEA) or where no Minebea Intec subsidiaries or dealerships are located, please contact your local authorities or a commercial disposal operator. Remove the batteries and hand them in to a collection point prior to disposal/scraping of the device. Minebea Intec, its affiliates, subsidiaries, dealers and distributors will not take back equipment contaminated with hazardous materials (ABC contamination) – either for repair or disposal.

Please refer to our website (www.Minebea-Intec.com) or contact the Minebea Intec Service Department for more detailed information regarding repair service addresses or the disposal of your device.

Please see our T&Cs for further information.

Service addresses for repairs are listed in the product information supplied with the product and on our website (www.minebea-intec.com).

Should you have any further questions, please contact your local service representative or our service center in Hamburg:

Minebea Intec GmbH
Repair Center
Meiendorfer Strasse 205
22145 Hamburg, Germany
Tel.: +49 (0)40 67960 666

Use in Legal Metrology in the EU (or EEA)

The Weighing Platform as a Part of a Verifiable Weighing System

The weighing platform is to be considered a modular device. This modular device constitutes a verifiable weighing system only in combination with a suitable indicator (such as any of the Combics indicators).

Neither the weighing platform nor the weighing system may be used for weighing goods intended for direct sale to the public, nor, prior to initial verification, for legal metrology. The verifiable weighing capacity, preloads and permitted indicators from Minebea Intec are listed in the Declarations of Conformity.

Accessories

Electrical accessories

Plug and socket set to connect similar weighing platforms to indicators (separable connection)	YAS99I
Connection cable for platforms, cable connection boxes, or weighing equipment, 8 × 0,5 mm ² , approx. 8 mm exterior diameter, shielded, sold by the meter, for own assembly of final product *3	69Y01100

Mechanical accessories

Drive-on ramp, painted, for platform sizes:

Platform size in mm	Ramp width	Accessory no.
800 × 600	600	YAR01CWP
800 × 800	800	YAR06CWP
1000 × 1000	1000	YAR02CWP
1250 × 1000	1000	YAR02CWP
1250 × 1250	1250	YAR03CWP
1500 × 1250	1250	YAR03CWP
1500 × 1500	1500	YAR04CWP
2000 × 1500	1500	YAR05CWP

Drive-on ramp, painted (tread plate), for platform sizes:

Platform size in mm	Ramp width	Accessory no.
800 × 600	600	YAR01CWPT
1000 × 1000	1000	YAR02CWPT
1250 × 1000	1000	YAR02CWPT
1500 × 1250	1250	YAR03CWPT
1500 × 1500	1500	YAR04CWPT
2000 × 1500	1500	YAR05CWPT

Drive-on ramp, stainless steel, for platform sizes:

Platform size in mm	Ramp width	Accessory no.
800 × 600	600	YAR01CWS
800 × 800	800	YAR06CWS
1000 × 1000	1000	YAR02CWS
1250 × 1000	1000	YAR02CWS
1250 × 1250	1250	YAR03CWS
1500 × 1250	1250	YAR03CWS
1500 × 1500	1500	YAR04CWS
2000 × 1500	1500	YAR05CWS

Drive-on ramp, stainless steel (tread plate), for platform sizes:

Platform size in mm	Ramp width	Accessory no.
800 × 600	600	YAR01CWST
1000 × 1000	1000	YAR02CWST
1250 × 1000	1000	YAR02CWST
1500 × 1250	1250	YAR03CWST
1500 × 1500	1500	YAR04CWST
2000 × 1500	1500	YAR05CWST

Drive-on ramp, AISI 316 Ti stainless steel, for platform sizes:

Platform size in mm	Ramp width	Accessory no.
800 × 600	600	YAR01CWS4
1000 × 1000	1000	YAR02CWS4
1250 × 1000	1000	YAR02CWS4
1500 × 1250	1250	YAR03CWS4
1500 × 1500	1500	YAR04CWS4
2000 × 1500	1500	YAR05CWS4

Frame for pit installation, painted, for platform sizes:

Platform size in mm	Ramp width	Accessory no.
800 × 600	600×	YEG01CWP
800 × 800	800×	YEG08CWP
1000 × 1000	1000×	YEG02CWP
1250 × 1000	1000×	YEG03CWP
1250 × 1250	1250×	YEG09CWP
1500 × 1250	1250×	YEG04CWP
1500 × 1500	1500×	YEG05CWP
2000 × 1500	1500×	YEG06CWP

Frame for pit installation, stainless steel, for platform sizes:

Platform size in mm	Frame width	Accessory no.
800 × 600	600	YEG01CWS
800 × 800	800	YEG08CWS
1000 × 1000	1000	YEG02CWS
1250 × 1000	1000	YEG03CWS
1250 × 1250	1250	YEG09CWS
1500 × 1250	1250	YEG04CWS
1500 × 1500	1500	YEG05CWS
2000 × 1500	1500	YEG06CWS

Roller conveyor, painted, for platform sizes:

Size in mm	Accessory no.
320 × 240	YRC01DCA
400 × 300	YRC01EDA
500 × 400	YRC01FEA
650 × 500	YRC01GFP
800 × 600	YRC01IGP

Roller conveyor, stainless steel, for platform sizes:

Size in mm	Accessory no.
320 × 240	YRC01DCS
400 × 300	YRC01EDS
500 × 400	YRC01FES
650 × 500	YRC01GFS

Set of stainless steel floor fasteners

	Accessory no.
(2 fastening plates, 4 special dowel screws)	YFP01CWS

Fastening kit for locking the two feet of the weighing platform to the ramp and for all applications with pit installation from size 800 × 800 mm

YFP02CWS

Column, painted, for attaching indicator to platform, for sizes:

Size in mm	Accessory no.
320 × 240, height 330	YDH01CWP
400 × 300, height 500	YDH02CWP
500 × 400, height 500	YDH02CWP
500 × 400, height 750	YDH03CWP
650 × 500, height 750	YDH03CWP

Column, stainless steel, for attaching indicator to platform, for sizes:

Size in mm	Accessory no.
320 × 240, height 330	YDH01CWS
400 × 300, height 500	YDH02CWS
500 × 400, height 500	YDH02CWS
500 × 400, height 750	YDH03CWS

Bench, painted, for sizes:

Size in mm	Accessory no.
400 × 300, height 645 (min) Adjustable to a max. height of 675 mm	YWT01CWP
500 × 400, height 645 (min) Adjustable to a max. height of 675 mm	YWT02CWP
650 × 500, height 645 (min) Adjustable to a max. height of 675 mm	YWT03CWP
800 × 600, height 645 (min) Adjustable to a max. height of 675 mm	YWT04CWP

Bench, stainless steel, for sizes:

Size in mm	Accessory no.
400 × 300, height 645 (min) Adjustable to a max. height of 675 mm	YWT01CWS
500 × 400, height 645 (min) Adjustable to a max. height of 675 mm	YWT02CWS
650 × 500, height 645 (min) Adjustable to a max. height of 675 mm	YWT03CWS
800 × 600, height 645 (min) Adjustable to a max. height of 675 mm	YWT04CWS

Column for bench, painted, for attaching indicator,
adjustable height:

Size in mm	Accessory no.
400×300	YDH01WTCWP

Column for bench, stainless steel, for attaching indicator,
adjustable height:

Size in mm	Accessory no.
400×300	YDH01WTCWS

Floor fastening set	Accessory no.
---------------------	---------------

Plate for attaching indicator and printer to bench stand	YPP01CWS
---	----------

Set of castors for bench (2 guide castors, 2 lockable castors)	YRO01WTCW
---	-----------

Retainer for barcode scanner, for attachment to bench stand	YBH01CWS
--	----------

“EC Verification” –

A Service Offered by Minebea Intec

Our service technicians authorized to perform the verification of your weighing instruments that are acceptable for legal metrological verification can inspect and verify the metrological specifications at the place of installation within the Member States of the European Union and the Signatories of the Agreement on the European Economic Area.

Subsequent Verifications within the Europe

The validity of the verification will become void in accordance with the national regulations of the country in which the weighing instrument is used. For information on verification and legal regulations currently applicable in your country, and to obtain the names of the persons to contact, please contact your local Minebea Intec office, dealer or service center.

If you use electrical equipment in installations and under ambient conditions requiring higher safety standards, you must comply with the provisions as specified in the applicable regulations for installation in your country.



EU-Konformitätserklärung EU Declaration of Conformity

Hersteller
Manufacturer Minebea Intec Bovenden GmbH & Co. KG
Leinetal 2, 37120 Bovenden, Germany
erklärt in alleiniger Verantwortung, dass das Betriebsmittel
declares under sole responsibility that the equipment

Geräteart
Device type Combics Wägeplattform
Combics weighing platform

Baureihe
Type series CAAPP1, CAAPP4, CAAPS1, CAAPS4

in der von uns in Verkehr gebrachten Ausführung allen einschlägigen Bestimmungen der folgenden Europäischen Richtlinien - einschließlich deren zum Zeitpunkt der Erklärung geltenden Änderungen - entspricht und die anwendbaren Anforderungen folgender harmonisierter Europäischer Normen erfüllt:
in the form as delivered fulfils all the relevant provisions of the following European Directives - including any amendments valid at the time this declaration was signed - and meets the applicable requirements of the harmonized European Standards listed below:

2014/30/EU Elektromagnetische Verträglichkeit
Electromagnetic compatibility
EN 61326-1:2013

2011/65/EU Beschränkung der Verwendung bestimmter gefährlicher Stoffe in Elektro- und Elektronikgeräten (RoHS)
Restriction of the use of certain hazardous substances in electrical and electronic equipment (RoHS)
EN 50581:2012

Nur für Geräte mit Option Y2 | *Only for devices with option Y2*
2014/34/EU Geräte und Schutzsysteme zur bestimmungsgemäßen Verwendung in explosionsgefährdeten Bereichen
Equipment and protective systems intended for use in potentially explosive atmospheres
EN 60079-0:2012, EN 60079-15:2010, EN 60079-31:2014

Kennzeichnung
Marking II 3G Ex nA IIC T6 Gc
II 3D Ex tc IIIC T80°C Dc

Referenz
Reference Herstellerbescheinigung Nummer: SIS14ATEX001X
Manufacturer's Certificate number:

Jahreszahl der CE-Kennzeichenvergabe | *Year of the CE mark assignment:* 17
Minebea Intec Bovenden GmbH & Co. KG
Bovenden, 2017-02-08

Dr. Bodo Krebs
President

Dr. Jörg Hachenberg
Head of Mechatronics

Diese Erklärung bescheinigt die Übereinstimmung mit den genannten EU-Richtlinien, ist jedoch keine Zusicherung von Eigenschaften. Bei einer mit uns nicht abgestimmten Änderung des Produktes verliert diese Erklärung ihre Gültigkeit. Die (Sicherheits-)hinweise der zugehörigen Produktdokumentation sind zu beachten.

This declaration certifies conformity with the above mentioned EU Directives, but does not guarantee product attributes. Unauthorised product modifications make this declaration invalid. The (safety) information in the associated product documentation must be observed.

Plattform / Platform CAP...-LCE, CAAP...-BCE, CAP...-NCE und / and CAAP...-NCE, in Kombination mit / in combination with SARTORIUS AG / Sartorius Weighing Technology GmbH ...	Typ / Type	Prüfschein / Test certificate	EG-Bauartzulassung / EC type-approval Wenn / if Sartorius
Auswertegerät / <i>Electronic evaluation unit YCO01IS-0CE mit Anzeige- und Bedieneinrichtung / with indicating and operator device</i> isi 10, isi 20 oder / or isi 30	(DX BD 323) SARTICS	D09-95.30 + D09-95.09	(D95-09-041) D04-09-015
Auswertegerät / <i>Indicator QCT01.. (incl. QAT01..., SEBT01..)</i>	(DX BI 500) SARTICS	D09-99.06	(D99-09-009) D04-09-015
Auswertelektronik / <i>Electronic evaluation unit YCO02IS-0CE mit Anzeige- und Bedieneinrichtung / with indicating and operator device</i> isi10., isi20., isi30, YAC01., YAC02., TN oder Computer (in Konformität mit 89/336/EEC) mit Software Sartorius Win Scale (D09-99.15) / or computer (CE conformity according to Council Directive 89/336/EEC) with software Sartorius Win Scale (D09-99.15)	iso-TEST + Prüfschein / Test Certificate YCO02IS-0CE	D09-00.28	D97-09-018
Auswertegerät / <i>Indicator FCT01-X (incl. SECT01..)</i> Ausnahme für die Kompatibilität: Variante FCT01-XV1 <i>Exception for the compatibility: Variant FCT01-XV1</i>	(DX BM 500) SARTICS	D09-03.29	(D00-09-022) D04-09-015
Auswertegerät / <i>Indicator TN und / and TN-X (incl. CIS..., CIXS..)</i>	(DX BO 300) SARTICS	D09-03.13	(D02-09-007) D04-09-015
Auswertegerät / <i>Indicator TN-Pro (CISPRO)</i>	SARTICS	D09-06.13	D04-09-015
Auswertegerät / <i>Indicator TM (MIS...)</i>	SARTICS	D09-07.21	D04-09-015
Auswertegerät / <i>Indicator TA (CAIS..., CAISL...)</i>	SARTOCOMB	D09-11.02	T7884

Plattform / Platform CAP...-LCE, CAAP...-BCE, CAP...-NCE und / and CAAP...-NCE, in Kombination mit / in combination with SARTORIUS Hamburg GmbH / SARTORIUS Mechatronics T & H GmbH ...	Typ / Type	Prüfschein / Test certificate	EG-Bauartzulassung / EC type-approval
Auswertegerät / <i>Indicator PR1713...,PR5610(X5), PR5710(X6) bei / at U_{exc} = 12V</i>	(PR1713...) (PR5610(X5)) (PR5710(X6)) SARTICS	D09-02.32	(D99-09-039) D04-09-015
Auswertegerät / <i>Indicator PR5510/xx (X4) bei / at U_{exc} = 12V</i>	SARTICS	D09-04.07	D04-09-015

Gilt nicht bei Verwendung des Wägezellentrennschaltgerätes PR1626_60 für explosionsgefährdete Bereiche.
Not valid for use of the intrinsically safe load cell interface PR1626_60 for hazardous areas.

Alle Klasse III / all class III
Kabellänge / Cable length ≤ 20 m



Einbereichswaagen / *Single range instruments*

CAPP1...-LCE + CAAPP1...-BCE

Modell / Model	Max (kg) ≤	e (g)	Min (g)	Abmess- ungen / Dimensions (mm) ≤	Einschalt- nullstellbereich + zusätzliche Totlast / Initial zero setting range + additional dead load (kg) ≤ ±	Wägezellenhersteller u. Wägezellen- kennzeichnung / load cell manufacturer and load cell marking	load cell Zertifikat Nr. / Certificate no.
CAPP1-3DC-LCE CAAPP1-3DC-BCE	3	1	20	320x240	0,6	011241/7,5kgC3	TC6266 Rev. 1
CAPP1-6DC-LCE CAAPP1-6DC-BCE	6	2	40	320x240	1,2	011242/15kgC3	TC6266 Rev. 1
CAPP1-15DC-LCE CAAPP1-15DC-BCE	15	5	100	320x240	3	011243/30kgC3	TC6266 Rev. 1
CAPP1-30ED-LCE CAAPP1-30ED-BCE	30	10	200	400x300	6	011244/50kgC3	TC6267 Rev. 1
CAPP1-60ED-LCE CAAPP1-60ED-BCE	60	20	400	400x300	12	011245/100kgC3	TC6267 Rev. 1
CAPP1-30FE-LCE CAAPP1-30FE-BCE	30	10	200	500x400	6	011246/50kgC3	TC6269 Rev. 1
CAPP1-60FE-LCE CAAPP1-60FE-BCE	60	20	400	500x400	12	011247/100kgC3	TC6269 Rev. 1
CAPP1-150FE-LCE CAAPP1-150FE-BCE	150	50	1000	500x400	30	011248/200kgC3	TC6269 Rev. 1
CAPP1-60GF-LCE CAAPP1-60GF-BCE	60	20	400	650x500	12	011249/100kgC3	TC6270 Rev. 1
CAPP1-150GF-LCE CAAPP1-150GF-BCE	150	50	1000	650x500	30	011250/200kgC3	TC6270 Rev. 1
CAPP1-300GF-LCE CAAPP1-300GF-BCE	300	100	2000	650x500	60	011251/500kgC3	TC6270 Rev. 1
CAPP1-60IG-LCE CAAPP1-60IG-BCE	60	20	400	800x600	12	011252/150kgC3	TC6268 Rev. 1
CAPP1-150IG-LCE CAAPP1-150IG-BCE	150	50	1000	800x600	30	011253/250kgC3	TC6268 Rev. 1
CAPP1-300IG-LCE CAAPP1-300IG-BCE	300	100	2000	800x600	60	011290/500kgC3	TC6268 Rev. 1



CAPP4...-LCE + CAAPP4...-BCE

Modell / Model	Max (kg) ≤	e (g)	Min (g)	Abmess- ungen / Dimensions (mm) ≤	Einschalt- nullstellbereich + zusätzliche Totlast / Initial zero setting range + additional dead load (kg) ≤ ±	Wägezellenhersteller u. Wägezellenkenn- zeichnung / load cell manufacturer and load cell marking	load cell Zertifikat Nr. / Certificate no.
CAPP4-150II-LCE CAAPP4-150II-BCE	150	50	1000	800x800	30	MP58T/91kgC3MR	D09-04.20
CAPP4-300II-LCE CAAPP4-300II-BCE	300	100	2000	800x800	60	011469/220kgC3 011470/220kgC3 MP58T/227kgC3MR	TC7822 Rev. 0 D09-04.20
CAPP4-600II-LCE CAAPP4-600II-BCE	600	200	4000	800x800	120	011231/550kgC3 011309/550kgC3 MP58T/454kgC3MR	TC7822 Rev. 0 D09-04.20
CAPP4-1500II-LCE CAAPP4-1500II-BCE	1500	500	10000	800x800	300	011232/1100kgC3 011310/1100kgC3 MP58T/1134kgC3MR	TC7822 Rev. 0 D09-04.20
CAPP4-3000II-LCE CAAPP4-3000II-BCE	3000	1000	20000	800x800	600	011233/1760kgC3 011311/1760kgC3 MP58T/2268kgC3MR	TC7822 Rev. 0 D09-04.20
CAPP4-150LI-LCE CAAPP4-150LI-BCE	150	50	1000	1000x800	30	MP58T/91kgC3MR	D09-04.20
CAPP4-300LI-LCE CAAPP4-300LI-BCE	300	100	2000	1000x800	60	011469/220kgC3 011470/220kgC3 MP58T/227kgC3MR	TC7822 Rev. 0 D09-04.20
CAPP4-600LI-LCE CAAPP4-600LI-BCE	600	200	4000	1000x800	120	011231/550kgC3 011309/550kgC3 MP58T/454kgC3MR	TC7822 Rev. 0 D09-04.20
CAPP4-1500LI-LCE CAAPP4-1500LI-BCE	1500	500	10000	1000x800	300	011232/1100kgC3 011310/1100kgC3 MP58T/1134kgC3MR	TC7822 Rev. 0 D09-04.20
CAPP4-3000LI-LCE CAAPP4-3000LI-BCE	3000	1000	20000	1000x800	600	011233/1760kgC3 011311/1760kgC3 MP58T/2268kgC3MR	TC7822 Rev. 0 D09-04.20
CAPP4-150LL-LCE CAAPP4-150LL-BCE	150	50	1000	1000x1000	30	MP58T/91kgC3MR	D09-04.20
CAPP4-300LL-LCE CAAPP4-300LL-BCE	300	100	2000	1000x1000	60	011469/220kgC3 011470/220kgC3 MP58T/227kgC3MR	TC7822 Rev. 0 D09-04.20
CAPP4-600LL-LCE CAAPP4-600LL-BCE	600	200	4000	1000x1000	120	011231/550kgC3 011309/550kgC3 MP58T/454kgC3MR	TC7822 Rev. 0 D09-04.20
CAPP4-1500LL-LCE CAAPP4-1500LL-BCE	1500	500	10000	1000x1000	300	011232/1100kgC3 011310/1100kgC3 MP58T/1134kgC3MR	TC7822 Rev. 0 D09-04.20
CAPP4-3000LL-LCE CAAPP4-3000LL-BCE	3000	1000	20000	1000x1000	600	011233/1760kgC3 011311/1760kgC3 MP58T/2268kgC3MR	TC7822 Rev. 0 D09-04.20
CAPP4-150NL-LCE CAAPP4-150NL-BCE	150	50	1000	1250x1000	30	MP58T/227kgC3MR	D09-04.20
CAPP4-300NL-LCE CAAPP4-300NL-BCE	300	100	2000	1250x1000	60	011469/220kgC3 011470/220kgC3 MP58T/227kgC3MR	TC7822 Rev. 0 D09-04.20
CAPP4-600NL-LCE CAAPP4-600NL-BCE	600	200	4000	1250x1000	120	011231/550kgC3 011309/550kgC3 MP58T/454kgC3MR	TC7822 Rev. 0 D09-04.20
CAPP4-1500NL-LCE CAAPP4-1500NL-BCE	1500	500	10000	1250x1000	300	011232/1100kgC3 011310/1100kgC3 MP58T/1134kgC3MR	TC7822 Rev. 0 D09-04.20
CAPP4-3000NL-LCE CAAPP4-3000NL-BCE	3000	1000	20000	1250x1000	600	011233/1760kgC3 011311/1760kgC3 MP58T/2268kgC3MR	TC7822 Rev. 0 D09-04.20
CAPP4-150NN-LCE CAAPP4-150NN-BCE	150	50	1000	1250x1250	30	MP58T/227kgC3MR	D09-04.20
CAPP4-300NN-LCE CAAPP4-300NN-BCE	300	100	2000	1250x1250	60	011469/220kgC3 011470/220kgC3 MP58T/227kgC3MR	TC7822 Rev. 0 D09-04.20
CAPP4-600NN-LCE CAAPP4-600NN-BCE	600	200	4000	1250x1250	120	011231/550kgC3 011309/550kgC3 MP58T/454kgC3MR	TC7822 Rev. 0 D09-04.20

M11-007-002-02-de

08.06.2011

3/11

Fortsetzung / Continuation CAPP4...-LCE + CAAPP4...-BCE

Modell / Model	Max (kg) ≤	e (g)	Min (g)	Abmess- ungen / Dimensions (mm) ≤	Einschalt- nullstellbereich + zusätzliche Totlast / Initial zero setting range + additional dead load (kg) ≤ ±	Wägezellenhersteller u. Wägezellenkenn- zeichnung / load cell manufacturer and load cell marking	load cell Zertifikat Nr. / Certificate no.
CAPP4-1500NN-LCE CAAPP4-1500NN-BCE	1500	500	10000	1250x1250	300	011232/1100kgC3 011310/1100kgC3 MP58T/1134kgC3MR	TC7822 Rev. 0 D09-04.20
CAPP4-3000NN-LCE CAAPP4-3000NN-BCE	3000	1000	20000	1250x1250	600	011233/1760kgC3 011311/1760kgC3 MP58T/2268kgC3MR	TC7822 Rev. 0 D09-04.20
CAPP4-600RN-LCE CAAPP4-600RN-BCE	600	200	4000	1500x1250	120	011231/550kgC3 011309/550kgC3 MP58T/454kgC3MR	TC7822 Rev. 0 D09-04.20
CAPP4-1500RN-LCE CAAPP4-1500RN-BCE	1500	500	10000	1500x1250	300	011232/1100kgC3 011310/1100kgC3 MP58T/1134kgC3MR	TC7822 Rev. 0 D09-04.20
CAPP4-3000RN-LCE CAAPP4-3000RN-BCE	3000	1000	20000	1500x1250	600	011233/1760kgC3 011311/1760kgC3 MP58T/2268kgC3MR	TC7822 Rev. 0 D09-04.20
CAPP4-600RR-LCE CAAPP4-600RR-BCE	600	200	4000	1500X1500	120	011231/550kgC3 011309/550kgC3 MP58T/454kgC3MR	TC7822 Rev. 0 D09-04.20
CAPP4-1500RR-LCE CAAPP4-1500RR-BCE	1500	500	10000	1500X1500	300	011232/1100kgC3 011310/1100kgC3 MP58T/1134kgC3MR	TC7822 Rev. 0 D09-04.20
CAPP4-3000RR-LCE CAAPP4-3000RR-BCE	3000	1000	20000	1500X1500	600	011233/1760kgC3 011311/1760kgC3 MP58T/2268kgC3MR	TC7822 Rev. 0 D09-04.20
CAPP4-600WR-LCE CAAPP4-600WR-BCE	600	200	4000	2000X1500	120	011231/550kgC3 011309/550kgC3 MP58T/454kgC3MR	TC7822 Rev. 0 D09-04.20
CAPP4-1500WR-LCE CAAPP4-1500WR-BCE	1500	500	10000	2000X1500	300	011232/1100kgC3 011310/1100kgC3 MP58T/1134kgC3MR	TC7822 Rev. 0 D09-04.20
CAPP4-3000WR-LCE CAAPP4-3000WR-BCE	3000	1000	20000	2000X1500	600	011233/1760kgC3 011311/1760kgC3 MP58T/2268kgC3MR	TC7822 Rev. 0 D09-04.20

CAPS1...-LCE + CAAPS1...-BCE

Modell / Model	Max (kg) ≤	e (g)	Min (g)	Abmess- ungen / Dimensions (mm) ≤	Einschalt- nullstellbereich + zusätzliche Totlast / Initial zero setting range + additional dead load (kg) ≤ ±	Wägezellenhersteller u. Wägezellenkenn- zeichnung / load cell manufacturer and load cell marking	load cell Zertifikat Nr. / Certificate no.
CAPS1-3DC-LCE CAAPS1-3DC-BCE	3	1	20	320x240	0,6	011293/7,5kgC3	TC6271 Rev. 1
CAPS1-6DC-LCE CAAPS1-6DC-BCE	6	2	40	320x240	1,2	011294/15kgC3	TC6271 Rev. 1
CAPS1-15DC-LCE CAAPS1-15DC-BCE	15	5	100	320x240	3	011295/30kgC3	TC6271 Rev. 1
CAPS1-30ED-LCE CAAPS1-30ED-BCE	30	10	200	400x300	6	011296/50kgC3	TC6271 Rev. 1
CAPS1-60ED-LCE CAAPS1-60ED-BCE	60	20	400	400x300	12	011297/100kgC3	TC6271 Rev. 1
CAPS1-30FE-LCE CAAPS1-30FE-BCE	30	10	200	500x400	6	011296/50kgC3	TC6271 Rev. 1
CAPS1-60FE-LCE CAAPS1-60FE-BCE	60	20	400	500x400	12	011297/100kgC3	TC6271 Rev. 1
CAPS1-150FE-LCE CAAPS1-150FE-BCE	150	50	1000	500x400	30	011298/200kgC3	TC6271 Rev. 1



CAPS4....-LCE + CAAPS4...-BCE

Modell / Model	Max (kg) ≤	e (g)	Min (g)	Abmess- ungen / Dimensions (mm) ≤	Einschalt- nullstellbereich + zusätzliche Totlast / Initial zero setting range + additional dead load (kg) ≤ ±	Wägezellenhersteller u. Wägezellenkenn- zeichnung / load cell manufacturer and load cell marking	load cell Zertifikat Nr. / Certificate no.
CAPS4-60GF-LCE CAAPS4-60GF-BCE	60	20	400	650x500	12	011272/50kgC3 011305/50kgC3	TC6272 Rev. 1
CAPS4-150GF-LCE CAAPS4-150GF-BCE	150	50	1000	650x500	30	011273/100kgC3 011306/100kgC3	TC6272 Rev. 1
CAPS4-300GF-LCE CAAPS4-300GF-BCE	300	100	2000	650x500	60	011274/200kgC3 011307/200kgC3	TC6272 Rev. 1
CAPS4-60IG-LCE CAAPS4-60IG-BCE	60	20	400	800x600	12	011272/50kgC3 011305/50kgC3	TC6272 Rev. 1
CAPS4-150IG-LCE CAAPS4-150IG-BCE	150	50	1000	800x600	300	011273/100kgC3 011306/100kgC3	TC6272 Rev. 1
CAPS4-300IG-LCE CAAPS4-300IG-BCE	300	100	2000	800x600	60	011274/200kgC3 011307/200kgC3	TC6272 Rev. 1
CAPS4-600IG-LCE CAAPS4-600IG-BCE	600	200	4000	800x600	120	011275/500kgC3 011308/500kgC3	TC6272 Rev. 1
CAPS4-150II-LCE CAAPS4-150II-BCE	150	50	1000	800x800	30	MP58T/91kgC3MR	D09-04.20
CAPS4-300II-LCE CAAPS4-300II-BCE	300	100	2000	800x800	60	011469/220kgC3 011470/220kgC3 HBM_HLC B2-C3-220kg	TC7822 Rev. 0 TC6524 Rev.1
CAPS4-600II-LCE CAAPS4-600II-BCE	600	200	4000	800x800	120	011231/550kgC3 011309/550kgC3 HBM_HLC B2-C3-550kg	TC7822 Rev. 0 TC6524 Rev.1
CAPS4-1500II-LCE CAAPS4-1500II-BCE	1500	500	10000	800x800	300	011232/1100kgC3 011310/1100kgC3 HBM_HLC B2-C3-1100kg	TC7822 Rev. 0 TC6524 Rev.1
CAPS4-3000II-LCE CAAPS4-3000II-BCE	3000	1000	20000	800x800	600	011233/1760kgC3 011311/1760kgC3 HBM_HLC B2-C3-1760kg	TC7822 Rev. 0 TC6524 Rev.1
CAPS4-150LI-LCE CAAPS4-150LI-BCE	150	50	1000	800x800	30	MP58T/91kgC3MR	D09-04.20
CAPS4-300LI-LCE CAAPS4-300LI-BCE	300	100	2000	1000x800	60	011469/220kgC3 011470/220kgC3 HBM_HLC B2-C3-220kg	TC7822 Rev. 0 TC6524 Rev.1
CAPS4-600LI-LCE CAAPS4-600LI-BCE	600	200	4000	1000x1000	120	011231/550kgC3 011309/550kgC3 HBM_HLC B2-C3-550kg	TC7822 Rev. 0 TC6524 Rev.1
CAPS4-1500LI-LCE CAAPS4-1500LI-BCE	1500	500	10000	1000x1000	300	011232/1100kgC3 011310/1100kgC3 HBM_HLC B2-C3-1100kg	TC7822 Rev. 0 TC6524 Rev.1
CAPS4-3000LI-LCE CAAPS4-3000LI-BCE	3000	1000	20000	1000x1000	600	011233/1760kgC3 011311/1760kgC3 HBM_HLC B2-C3-1760kg	TC7822 Rev. 0 TC6524 Rev.1
CAPS4-150LL-LCE CAAPS4-150LL-BCE	150	50	1000	1000x1000	30	MP58T/91kgC3MR	D09-04.20
CAPS4-300LL-LCE CAAPS4-300LL-BCE	300	100	2000	1000x1000	60	011469/220kgC3 011470/220kgC3 HBM_HLC B2-C3-220kg	TC7822 Rev. 0 TC6524 Rev.1
CAPS4-600LL-LCE CAAPS4-600LL-BCE	600	200	4000	1000x1000	120	011231/550kgC3 011309/550kgC3 HBM_HLC B2-C3-550kg	TC7822 Rev. 0 TC6524 Rev.1
CAPS4-1500LL-LCE CAAPS4-1500LL-BCE	1500	500	10000	1000x1000	300	011232/1100kgC3 011310/1100kgC3 HBM_HLC B2-C3-1100kg	TC7822 Rev. 0 TC6524 Rev.1
CAPS4-3000LL-LCE CAAPS4-3000LL-BCE	3000	1000	20000	1000x1000	600	011233/1760kgC3 011311/1760kgC3 HBM_HLC B2-C3-1760kg	TC7822 Rev. 0 TC6524 Rev.1
CAPS4-150NL-LCE CAAPS4-150NL-BCE	150	50	1000	1250x1000	30	MP58T/227kgC3MR	D09-04.20
CAPS4-300NL-LCE CAAPS4-300NL-BCE	300	100	2000	1250x1000	60	011469/220kgC3 011470/220kgC3 HBM_HLC B2-C3-220kg	TC7822 Rev. 0 TC6524 Rev.1
CAPS4-600NL-LCE CAAPS4-600NL-BCE	600	200	4000	1250x1000	120	011231/550kgC3 011309/550kgC3 HBM_HLC B2-C3-550kg	TC7822 Rev. 0 TC6524 Rev.1

M11-007-002-02-de

08.06.2011

5/11

Fortsetzung / Continuation CAPS4....-LCE + CAAPS4...-BCE

Modell / Model	Max (kg) ≤	e (g)	Min (g)	Abmess- ungen / Dimensions (mm) ≤	Einschalt- nullstellbereich + zusätzliche Totlast / Initial zero setting range + additional dead load (kg) ≤ ±	Wägezellenhersteller u. Wägezellenkenn- zeichnung / load cell manufacturer and load cell marking	load cell Zertifikat Nr. / Certificate no.
CAPS4-1500NL-LCE CAAPS4-1500NL-BCE	1500	500	10000	1250x1000	300	011232/1100kgC3 011310/1100kgC3 HBM_HLC B2-C3-1100kg	TC7822 Rev. 0 TC6524 Rev. 1
CAPS4-3000NL-LCE CAAPS4-3000NL-BCE	3000	1000	20000	1250x1000	600	011233/1760kgC3 011311/1760kgC3 HBM_HLC B2-C3-1760kg	TC7822 Rev. 0 TC6524 Rev. 1
CAPS4-150NN-LCE CAAPS4-150NN-BCE	150	50	1000	1250x1250	30	MP58T/227kgC3MR	D09-04.20
CAPS4-300NN-LCE CAAPS4-300NN-BCE	300	100	2000	1250x1250	60	011469/220kgC3 011470/220kgC3 HBM_HLC B2-C3-220kg	TC7822 Rev. 0 TC6524 Rev. 1
CAPS4-600NN-LCE CAAPS4-600NN-BCE	600	200	4000	1250x1250	120	011231/550kgC3 011309/550kgC3 HBM_HLC B2-C3-550kg	TC7822 Rev. 0 TC6524 Rev. 1
CAPS4-1500NN-LCE CAAPS4-1500NN-LCE	1500	500	10000	1250x1250	300	011232/1100kgC3 011310/1100kgC3 HBM_HLC B2-C3-1100kg	TC7822 Rev. 0 TC6524 Rev. 1
CAPS4-3000NN-LCE CAAPS4-3000NN-BCE	3000	1000	20000	1250x1250	600	011233/1760kgC3 011311/1760kgC3 HBM_HLC B2-C3-1760kg	TC7822 Rev. 0 TC6524 Rev. 1
CAPS4-600RN-LCE CAAPS4-600RN-BCE	600	200	4000	1500x1250	120	011231/550kgC3 011309/550kgC3 HBM_HLC B2-C3-550kg	TC7822 Rev. 0 TC6524 Rev. 1
CAPS4-1500RN-LCE CAAPS4-1500RN-BCE	1500	500	10000	1500x1250	300	011232/1100kgC3 011310/1100kgC3 HBM_HLC B2-C3-1100kg	TC7822 Rev. 0 TC6524 Rev. 1
CAPS4-3000RN-LCE CAAPS4-3000RN-BCE	3000	1000	20000	1500x1250	600	011233/1760kgC3 011311/1760kgC3 HBM_HLC B2-C3-1760kg	TC7822 Rev. 0 TC6524 Rev. 1
CAPS4-600RR-LCE CAAPS4-600RR-BCE	600	200	4000 0	1500X1500	120	011231/550kgC3 011309/550kgC3 HBM_HLC B2-C3-550kg	TC7822 Rev. 0 TC6524 Rev. 1
CAPS4-1500RR-LCE CAAPS4-1500RR-BCE	1500	500	10000	1500X1500	300	011232/1100kgC3 011310/1100kgC3 HBM_HLC B2-C3-1100kg	TC7822 Rev. 0 TC6524 Rev. 1
CAPS4-3000RR-LCE CAAPS4-3000RR-BCE	3000	1000	20000	1500X1500	600	011233/1760kgC3 011311/1760kgC3 HBM_HLC B2-C3-1760kg	TC7822 Rev. 0 TC6524 Rev. 1
CAPS4-600WR-LCE CAAPS4-600WR-BCE	600	200	4000	2000X1500	120	011231/550kgC3 011309/550kgC3 HBM_HLC B2-C3-550kg	TC7822 Rev. 0 TC6524 Rev. 1
CAPS4-1500WR-LCE CAAPS4-1500WR-BCE	1500	500	10000	2000X1500	300	011232/1100kgC3 011310/1100kgC3 HBM_HLC B2-C3-1100kg	TC7822 Rev. 0 TC6524 Rev. 1
CAPS4-3000WR-LCE CAAPS4-3000WR-BCE	3000	1000	20000	2000X1500	600	011233/1760kgC3 011311/1760kgC3 HBM_HLC B2-C3-1760kg	TC7822 Rev. 0 TC6524 Rev. 1



Zweibereichswaagen / Two range instruments**CAPP1...-NCE + CAAPP1...-NCE**

Modell / Model	Max (kg) ≤	e (g)	Min (g)	Abmess- ungen / Dimensions (mm) ≤	Einschalt- nullstellbereich + zusätzliche Totlast / Initial zero setting range + additional dead load (kg) ≤ ±	Wägezellenhersteller u. Wägezellenkenn- zeichnung / load cell manufacturer and load cell marking	load cell Zertifikat Nr. / Certificate no.
CAPP1-3DC-NCE	1,5	0,5	10	320x240	0,6	011241/7,5kgC3	TC6266 Rev. 1
CAAPP1-3DC-NCE	3	1	20				
CAPP1-6DC-NCE	3	1	20	320x240	51,2	011242/15kgC3	TC6266 Rev. 1
CAAPP1-6DC-NCE	6	2	40				
CAPP1-15DC-NCE	6	2	40	320x240	3	011243/30kgC3	TC6266 Rev. 1
CAAPP1-15DC-NCE	15	5	100				
CAPP1-30ED-NCE	15	5	100	400x300	6	011244/50kgC3	TC6267 Rev. 1
CAAPP1-30ED-NCE	30	10	200				
CAPP1-60ED-NCE	30	10	200	400x300	12	011245/100kgC3	TC6267 Rev. 1
CAAPP1-60ED-NCE	60	20	400				
CAPP1-30FE-NCE	15	5	100	500x400	6	011246/50kgC3	TC6269 Rev. 1
CAAPP1-30FE-NCE	30	10	200				
CAPP1-60FE-NCE	30	10	200	500x400	12	011247/100kgC3	TC6269 Rev. 1
CAAPP1-60FE-NCE	60	20	400				
CAPP1-150FE-NCE	60	20	400	500x400	30	011248/200kgC3	TC6269 Rev. 1
CAAPP1-150FE-NCE	150	50	1000				
CAPP1-60GF-NCE	30	10	200	650x500	12	011249/100kgC3	TC6270 Rev. 1
CAAPP1-60GF-NCE	60	20	400				
CAPP1-150GF-NCE	60	20	400	650x500	30	011250/200kgC3	TC6270 Rev. 1
CAAPP1-150GF-NCE	150	50	1000				
CAPP1-300GF-NCE	150	50	1000	650x500	60	011251/500kgC3	TC6270 Rev. 1
CAAPP1-300GF-NCE	300	100	2000				
CAPP1-60IG-NCE	30	10	200	800x600	12	011252/150kgC3	TC6268 Rev. 1
CAAPP1-60IG-NCE	60	20	400				
CAPP1-150IG-NCE	60	20	400	800x600	30	011253/250kgC3	TC6268 Rev. 1
CAAPP1-150IG-NCE	150	50	1000				
CAPP1-300IG-NCE	150	50	1000	800x600	60	011290/500kgC3	TC6268 Rev. 1
CAAPP1-300IG-NCE	300	100	2000				



CAPP4...-NCE + CAAPP4...-NCE

Modell / Model	Max (kg) ≤	e (g)	Min (g)	Abmess- ungen / Dimensions (mm) ≤	Einschalt- nullstellbereich + zusätzliche Totlast / Initial zero setting range + additional dead load (kg) ≤ ±	Wägezellen- hersteller u. Wägezellenkenn- zeichnung / load cell manufacturer and load cell marking	load cell Zertifikat Nr. / Certificate no.
CAPP4-150II-NCE	60	20	400	800x800	30	MP58T/91kgC3MR	D09-04.20
CAAPP4-150II-NCE	150	50	1000				
CAPP4-300II-NCE	150	50	1000	800x800	60	011469/220kgC3 011470/220kgC3	TC7822 Rev. 0
CAAPP4-300II-NCE	300	100	2000			MP58T/227kgC3MR	D09-04.20
CAPP4-600II-NCE	300	100	2000	800x800	120	011231/550kgC3 011309/550kgC3	TC7822 Rev. 0
CAAPP4-600II-NCE	600	200	4000			MP58T/454kgC3MR	D09-04.20
CAPP4-1500II-NCE	600	200	4000	800x800	300	011232/1100kgC3 011310/1100kgC3	TC7822 Rev. 0
CAAPP4-1500II-NCE	1500	500	10000			MP58T/1134kgC3MR	D09-04.20
CAPP4-3000II-NCE	1500	500	10000	800x800	600	011233/1760kgC3 011311/1760kgC3	TC7822 Rev. 0
CAAPP4-3000II-NCE	3000	1000	20000			MP58T/2268kgC3MR	D09-04.20
CAPP4-150LI-NCE	60	20	400	1000x800	30	MP58T/91kgC3MR	D09-04.20
CAAPP4-150LI-NCE	150	50	1000				
CAPP4-300LI-NCE	150	50	1000	1000x800	60	011469/220kgC3 011470/220kgC3	TC7822 Rev. 0
CAAPP4-300LI-NCE	300	100	2000			MP58T/227kgC3MR	D09-04.20
CAPP4-600LI-NCE	300	100	2000	1000x800	120	011231/550kgC3 011309/550kgC3	TC7822 Rev. 0
CAAPP4-600LI-NCE	600	200	4000			MP58T/454kgC3MR	D09-04.20
CAPP4-1500LI-NCE	600	200	4000	1000x800	300	011232/1100kgC3 011310/1100kgC3	TC7822 Rev. 0
CAAPP4-1500LI-NCE	1500	500	10000			MP58T/1134kgC3MR	D09-04.20
CAPP4-3000LI-NCE	1500	500	10000	1000x800	600	011233/1760kgC3 011311/1760kgC3	TC7822 Rev. 0
CAAPP4-3000LI-NCE	3000	1000	20000			MP58T/2268kgC3MR	D09-04.20
CAPP4-150LL-NCE	60	20	400	1000x1000	30	MP58T/91kgC3MR	D09-04.20
CAAPP4-150LL-NCE	150	50	1000				
CAPP4-300LL-NCE	150	50	1000	1000x1000	60	011469/220kgC3 011470/220kgC3	TC7822 Rev. 0
CAAPP4-300LL-NCE	300	100	2000			MP58T/227kgC3MR	D09-04.20
CAPP4-600LL-NCE	300	100	2000	1000x1000	120	011231/550kgC3 011309/550kgC3	TC7822 Rev. 0
CAAPP4-600LL-NCE	600	200	4000			MP58T/454kgC3MR	D09-04.20
CAPP4-1500LL-NCE	600	200	4000	1000x1000	300	011232/1100kgC3 011310/1100kgC3	TC7822 Rev. 0
CAAPP4-1500LL-NCE	1500	500	10000			MP58T/1134kgC3MR	D09-04.20
CAPP4-3000LL-NCE	1500	500	10000	1000x1000	600	011233/1760kgC3 011311/1760kgC3	TC7822 Rev. 0
CAAPP4-3000LL-NCE	3000	1000	20000			MP58T/2268kgC3MR	D09-04.20
CAPP4-300NL-NCE	150	50	1000	1250x1000	60	011469/220kgC3 011470/220kgC3	TC7822 Rev. 0
CAAPP4-300NL-NCE	300	100	2000			MP58T/227kgC3MR	D09-04.20
CAPP4-600NL-NCE	300	100	2000	1250x1000	120	011231/550kgC3 011309/550kgC3	TC7822 Rev. 0
CAAPP4-600NL-NCE	600	200	4000			MP58T/454kgC3MR	D09-04.20
CAPP4-1500NL-NCE	600	200	4000	1250x1000	300	011232/1100kgC3 011310/1100kgC3	TC7822 Rev. 0
CAAPP4-1500NL-NCE	1500	500	10000			MP58T/1134kgC3MR	D09-04.20
CAPP4-3000NL-NCE	1500	500	10000	1250x1000	600	011233/1760kgC3 011311/1760kgC3	TC7822 Rev. 0
CAAPP4-3000NL-NCE	3000	1000	20000			MP58T/2268kgC3MR	D09-04.20
CAPP4-300NN-NCE	150	50	1000	1250x1250	60	011469/220kgC3 011470/220kgC3	TC7822 Rev. 0
CAAPP4-300NN-NCE	300	100	2000			MP58T/227kgC3MR	D09-04.20
CAPP4-600NN-NCE	300	100	2000	1250x1250	120	011231/550kgC3 011309/550kgC3	TC7822 Rev. 0
CAAPP4-600NN-NCE	600	200	4000			MP58T/454kgC3MR	D09-04.20

M11-007-002-02-de

08.06.2011

8/11

Fortsetzung / Continuation CAPP4...-NCE + CAAPP4...-NCE

Modell / Model	Max (kg) ≤	e (g)	Min (g)	Abmess- ungen / Dimensions (mm) ≤	Einschalt- nullstellbereich + zusätzliche Totlast / Initial zero setting range + additional dead load (kg) ≤ ±	Wägezellen- hersteller u. Wägezellenkenn- zeichnung / load cell manufacturer and load cell marking	load cell Zertifikat Nr. / Certificate no.
CAPP4-1500NN-NCE CAAPP4-1500NN-NCE	600 1500	200 500	4000 10000	1250x1250	300	011232/1100kgC3 011310/1100kgC3 MP58T/1134kgC3MR	TC7822 Rev. 0 D09-04.20
CAPP4-3000NN-NCE CAAPP4-3000NN-NCE	1500 3000	500 1000	10000 20000				
CAPP4-600RN-NCE CAAPP4-600RN-NCE	300 600	100 200	2000 4000	1500x1250	120	011231/550kgC3 011309/550kgC3 MP58T/454kgC3MR	TC7822 Rev. 0 D09-04.20
CAPP4-1500RN-NCE CAAPP4-1500RN-NCE	600 1500	200 500	4000 10000				
CAPP4-3000RN-NCE CAAPP4-3000RN-NCE	1500 3000	500 1000	10000 20000	1500x1250	600	011233/1760kgC3 011311/1760kgC3 MP58T/2268kgC3MR	TC7822 Rev. 0 D09-04.20
CAPP4-600RR-NCE CAAPP4-600RR-NCE	300 600	100 200	2000 4000				
CAPP4-1500RR-NCE CAAPP4-1500RR-NCE	600 1500	200 500	4000 10000	1500X1500	300	011232/1100kgC3 011310/1100kgC3 MP58T/1134kgC3MR	TC7822 Rev. 0 D09-04.20
CAPP4-3000RR-NCE CAAPP4-3000RR-NCE	1500 3000	500 1000	10000 20000				
CAPP4-600WR-NCE CAAPP4-600WR-NCE	300 600	100 200	2000 4000	2000X1500	120	011231/550kgC3 011309/550kgC3 MP58T/454kgC3MR	TC7822 Rev. 0 D09-04.20
CAPP4-1500WR-NCE CAAPP4-1500WR-NCE	600 1500	200 500	4000 10000				
CAPP4-3000WR-NCE CAAPP4-3000WR-NCE	1500 3000	500 1000	10000 20000	2000X1500	600	011233/1760kgC3 011311/1760kgC3 MP58T/2268kgC3MR	TC7822 Rev. 0 D09-04.20
CAPP4-600WR-NCE CAAPP4-600WR-NCE	300 600	100 200	2000 4000				
CAPP4-1500WR-NCE CAAPP4-1500WR-NCE	600 1500	200 500	4000 10000	2000X1500	300	011232/1100kgC3 011310/1100kgC3 MP58T/1134kgC3MR	TC7822 Rev. 0 D09-04.20
CAPP4-3000WR-NCE CAAPP4-3000WR-NCE	1500 3000	500 1000	10000 20000				

CAPS1...-NCE + CAAPS1...-NCE

Modell / Model	Max (kg) ≤	e (g)	Min (g)	Abmess- ungen / Dimensions (mm) ≤	Einschalt- nullstellbereich + zusätzliche Totlast / Initial zero setting range + additional dead load (kg) ≤ ±	Wägezellenhersteller u. Wägezellenkenn- zeichnung / load cell manufacturer and load cell marking	load cell Zertifikat Nr. / Certificate no.
CAPS1-3DC-NCE CAAPS1-3DC-NCE	1,5 3	0,5 1	10 20	320x240	0,6	011293/7,5kgC3	TC6271 Rev. 1
CAPS1-6DC-NCE CAAPS1-6DC-NCE	3 6	1 2	20 40				
CAPS1-15DC-NCE CAAPS1-15DC-NCE	6 15	2 5	40 100	320x240	3	011295/30kgC3	TC6271 Rev. 1
CAPS1-30ED-NCE CAAPS1-30ED-NCE	15 30	5 10	100 200				
CAPS1-60ED-NCE CAAPS1-60ED-NCE	30 60	10 20	200 400	400x300	12	011297/100kgC3	TC6271 Rev. 1
CAPS1-30FE-NCE CAAPS1-30FE-NCE	15 30	5 10	100 200				
CAPS1-60FE-NCE CAAPS1-60FE-NCE	30 60	10 20	200 400	500x400	12	011297/100kgC3	TC6271 Rev. 1
CAPS1-150FE-NCE CAAPS1-150FE-NCE	60 150	20 50	400 1000				

M11-007-002-02-de

08.06.2011

9/11

CAPS4...-NCE + CAAPS4...-NCE

Modell / Model	Max (kg) ≤	e (g)	Min (g)	Abmess- ungen / Dimensions (mm) ≤	Einschalt- nullstellbereich + zusätzliche Totlast / Initial zero setting range + additional dead load (kg) ≤ ±	Wägezellen- hersteller u. Wägezellenkenn- zeichnung / load cell manufacturer and load cell marking	load cell Zertifikat Nr. / Certificate no.
CAPS4-60GF-NCE	30	10	200	650x500	12	011272/50kgC3	TC6272 Rev. 1
CAAPS4-60GF-NCE	60	20	400				
CAPS4-150GF-NCE	60	20	400	650x500	30	011273/100kgC3	TC6272 Rev. 1
CAAPS4-150GF-NCE	150	50	1000				
CAPS4-300GF-NCE	150	50	1000	650x500	60	011274/200kgC3	TC6272 Rev. 1
CAAPS4-300GF-NCE	300	100	2000				
CAPS4-60IG-NCE	30	10	200	800x600	12	011272/50kgC3	TC6272 Rev. 1
CAAPS4-60IG-NCE	60	20	400				
CAPS4-150IG-NCE	60	20	400	800x600	30	011273/100kgC3	TC6272 Rev. 1
CAAPS4-150IG-NCE	150	50	1000				
CAPS4-300IG-NCE	150	50	1000	800x600	60	011274/200kgC3	TC6272 Rev. 1
CAAPS4-300IG-NCE	300	100	2000				
CAPS4-600IG-NCE	300	100	2000	800x600	120	011275/500kgC3	TC6272 Rev. 1
CAAPS4-600IG-NCE	600	200	4000				
CAPS4-150II-NCE	60	20	400	800x800	30	MP58T/91kgC3MR	D09-04.20
CAAPS4-150II-NCE	150	50	1000				
CAPS4-300II-NCE	150	50	1000	800x800	60	011469/220kgC3	TC7822 Rev. 0
CAAPS4-300II-NCE	300	100	2000				
CAPS4-600II-NCE	300	100	2000	800x800	120	011231/550kgC3	TC7822 Rev. 0
CAAPS4-600II-NCE	600	200	4000				
CAPS4-1500II-NCE	600	200	4000	800x800	300	011232/1100kgC3	TC7822 Rev. 0
CAAPS4-1500II-NCE	1500	500	10000				
CAPS4-3000II-NCE	1500	500	10000	800x800	600	011233/1760kgC3	TC7822 Rev. 0
CAAPS4-3000II-NCE	3000	1000	20000				
CAPS4-150LI-NCE	60	20	400	800x800	30	MP58T/91kgC3MR	D09-04.20
CAAPS4-150LI-NCE	150	50	1000				
CAPS4-300LI-NCE	150	50	1000	1000x800	60	011469/220kgC3	TC7822 Rev. 0
CAAPS4-300LI-NCE	300	100	2000				
CAPS4-600LI-NCE	300	100	2000	1000x1000	120	011231/550kgC3	TC7822 Rev. 0
CAAPS4-600LI-NCE	600	200	4000				
CAPS4-1500LI-NCE	600	200	4000	1000x1000	300	011232/1100kgC3	TC7822 Rev. 0
CAAPS4-1500LI-NCE	1500	500	10000				
CAPS4-3000LI-NCE	1500	500	10000	1000x1000	600	011233/1760kgC3	TC7822 Rev. 0
CAAPS4-3000LI-NCE	3000	1000	20000				
CAPS4-150LL-NCE	60	20	400	1000x1000	30	MP58T/91kgC3MR	D09-04.20
CAAPS4-150LL-NCE	150	50	1000				
CAPS4-300LL-NCE	150	50	1000	1000x1000	60	011469/220kgC3	TC7822 Rev. 0
CAAPS4-300LL-NCE	300	100	2000				
CAPS4-600LL-NCE	300	100	2000	1000x1000	120	011231/550kgC3	TC7822 Rev. 0
CAAPS4-600LL-NCE	600	200	4000				
CAPS4-1500LL-NCE	600	200	4000	1000x1000	300	011232/1100kgC3	TC7822 Rev. 0
CAAPS4-1500LL-NCE	1500	500	10000				
CAPS4-3000LL-NCE	1500	500	10000	1000x1000	600	011233/1760kgC3	TC7822 Rev. 0
CAAPS4-3000LL-NCE	3000	1000	20000				
CAPS4-300NL-NCE	150	50	1000	1250x1000	60	011469/220kgC3	TC7822 Rev. 0
CAAPS4-300NL-NCE	300	100	2000				
CAPS4-600NL-NCE	300	100	2000	1250x1000	120	011231/550kgC3	TC7822 Rev. 0
CAAPS4-600NL-NCE	600	200	4000				
						011309/550kgC3	TC6524 Rev.1
						HBM_HLC B2-C3-550kg	TC6524 Rev.1

M11-007-002-02-de

08.06.2011

10/11

Fortsetzung / Continuation CAPS4...-NCE + CAAPS4...-NCE

Modell / Model	Max (kg) ≤	e (g)	Min (g)	Abmess- ungen / Dimensions (mm) ≤	Einschalt- nullstellbereich + zusätzliche Totlast / Initial zero setting range + additional dead load (kg) ≤ ±	Wägezellen- hersteller u. Wägezellenkenn- zeichnung / load cell manufacturer and load cell marking	load cell Zertifikat Nr. / Certificate no.
CAPS4-1500NL-NCE CAAPS4-1500NL-NCE	600 1500	200 500	4000 10000	1250x1000	300	011232/1100kgC3 011310/1100kgC3 HBM_HLC B2-C3-1100kg	TC7822 Rev. 0 TC6524 Rev.1
CAPS4-3000NL-NCE CAAPS4-3000NL-NCE	1500 3000	500 1000	10000 20000	1250x1000	600	011233/1760kgC3 011311/1760kgC3 HBM_HLC B2-C3-1760kg	TC7822 Rev. 0 TC6524 Rev.1
CAPS4-300NN-NCE CAAPS4-300NN-NCE	150 300	50 100	1000 2000	1250x1250	60	011469/220kgC3 011470/220kgC3 HBM_HLC B2-C3-220kg	TC7822 Rev. 0 TC6524 Rev.1
CAPS4-600NN-NCE CAAPS4-600NN-NCE	300 600	100 200	2000 4000	1250x1250	120	011231/550kgC3 011309/550kgC3 HBM_HLC B2-C3-550kg	TC7822 Rev. 0 TC6524 Rev.1
CAPS4-1500NN-NCE CAAPS4-1500NN-NCE	600 1500	200 500	4000 10000	1250x1250	300	011232/1100kgC3 011310/1100kgC3 HBM_HLC B2-C3-1100kg	TC7822 Rev. 0 TC6524 Rev.1
CAPS4-3000NN-NCE CAAPS4-3000NN-NCE	1500 3000	500 1000	10000 20000	1250x1250	600	011233/1760kgC3 011311/1760kgC3 HBM_HLC B2-C3-1760kg	TC7822 Rev. 0 TC6524 Rev.1
CAPS4-600RN-NCE CAAPS4-600RN-NCE	300 600	100 200	2000 4000	1500x1250	120	011231/550kgC3 011309/550kgC3 HBM_HLC B2-C3-550kg	TC7822 Rev. 0 TC6524 Rev.1
CAPS4-1500RN-NCE CAAPS4-1500RN-NCE	600 1500	200 500	4000 10000	1500x1250	300	011232/1100kgC3 011310/1100kgC3 HBM_HLC B2-C3-1100kg	TC7822 Rev. 0 TC6524 Rev.1
CAPS4-3000RN-NCE CAAPS4-3000RN-NCE	1500 3000	500 1000	10000 20000	1500x1250	600	011233/1760kgC3 011311/1760kgC3 HBM_HLC B2-C3-1760kg	TC7822 Rev. 0 TC6524 Rev.1
CAPS4-600RR-NCE CAAPS4-600RR-NCE	300 600	100 200	2000 4000	1500x1500	120	011231/550kgC3 011309/550kgC3 HBM_HLC B2-C3-550kg	TC7822 Rev. 0 TC6524 Rev.1
CAPS4-1500RR-NCE CAAPS4-1500RR-NCE	600 1500	200 500	4000 10000	1500x1500	300	011232/1100kgC3 011310/1100kgC3 HBM_HLC B2-C3-1100kg	TC7822 Rev. 0 TC6524 Rev.1
CAPS4-3000RR-NCE CAAPS4-3000RR-NCE	1500 3000	500 1000	10000 20000	1500x1500	600	011233/1760kgC3 011311/1760kgC3 HBM_HLC B2-C3-1760kg	TC7822 Rev. 0 TC6524 Rev.1
CAPS4-600WR-NCE CAAPS4-600WR-NCE	300 600	100 200	2000 4000	2000x1500	120	011231/550kgC3 011309/550kgC3 HBM_HLC B2-C3-550kg	TC7822 Rev. 0 TC6524 Rev.1
CAPS4-1500WR-NCE CAAPS4-1500WR-NCE	600 1500	200 500	4000 10000	2000x1500	300	011232/1100kgC3 011310/1100kgC3 HBM_HLC B2-C3-1100kg	TC7822 Rev. 0 TC6524 Rev.1
CAPS4-3000WR-NCE CAAPS4-3000WR-NCE	1500 3000	500 1000	10000 20000	2000x1500	600	011233/1760kgC3 011311/1760kgC3 HBM_HLC B2-C3-1760kg	TC7822 Rev. 0 TC6524 Rev.1



M11-007-002-02-de

08.06.2011

11/11

Plattform / Platform CAAP...-RCE, CAAP...-MCE und / and CAAP...-UCE, in Kombination mit / in combination with SARTORIUS AG / Sartorius Weighing Technology GmbH ...	Typ / Type	Prüfschein / Test certificate	EG-Bauartzulassung / EC type-approval Wenn / if Sartorius
Auswertegerät / <i>Electronic evaluation unit</i> YCO01IS-0CE mit Anzeige- und Bedieneinrichtung / <i>with indicating and operator device</i> isi 10, isi 20 oder / or isi 30	(DX BD 323) SARTICS	D09-95.30 + D09-95.09	(D95-09-041) D04-09-015
Auswerteelektronik / <i>Electronic evaluation unit</i> YCO02IS-0CE mit Anzeige- und Bedieneinrichtung / <i>with indicating and operator device</i> isi10..., isi20..., isi30, YAC01..., YAC02..., TN oder Computer (in Konformität mit 89/336/EEC) mit Software Sartorius Win Scale (D09-99.15) / <i>or computer (CE conformity according to Council Directive 89/336/EEC) with software Sartorius Win Scale (D09-99.15)</i>	iso-TEST + Prüfschein / <i>Test Certificate</i> YCO02IS-0CE	D09-00.28	D97-09-018 + D09-00.28
Auswertegerät / <i>Indicator</i> FCT01-X (incl. SECT01...) Ausnahme für die Kompatibilität: Variante FCT01-XV1 <i>Exception for the compatibility: Variant FCT01-XV1</i>	(DX BM 500) SARTICS	D09-03.29	(D00-09-022) D04-09-015
Auswertegerät / <i>Indicator</i> TN-X (CIXS..)	(DX BO 300) SARTICS	D09-03.13	(D02-09-007) D04-09-015
Auswertegerät / <i>Indicator</i> TN-Pro (CISPRO)	SARTICS	D09-06.13	D04-09-015
Auswertegerät / <i>Indicator</i> TA (CAIS..., CAISL...)	SARTOCOMB	D09-11.02	T7884

Alle Klasse III / all class III
Kabellänge / Cable length ≤ 20 m



Einbereichswaagen / Single range instruments**CAAPS4...-RCE**

Modell / Model	Max (kg) ≤	e (g)	Min (g)	Abmess- ungen / Dimensions (mm) ≤	Einschalt- stellbereich + zusätzliche Totlast / Initial zero setting range + additional dead Load (kg) ≤ ±	Wägezellen- hersteller u. Wägezellen- Kennzeichnung / load cell manufacturer and load cell marking	load cell Zertifikat Nr. / Certificate no.
CAAPS4-60GF-RCE	60	10	200	650x500	12	HBM_Z6F-C6-50kg	TC2207 Rev.3
CAAPS4-60IG-RCE	60	10	200	800x800	12	HBM_Z6F-C6-50kg	TC2207 Rev.3
CAAPS4-150GF-RCE	120	20	400	650x500	24	HBM_Z6F-C6-100kg	TC2207 Rev.3
CAAPS4-150IG-RCE	120	20	400	800x600	24	HBM_Z6F-C6-100kg	TC2207 Rev.3
CAAPS4-300GF-RCE	300	50	1000	650x500	60	HBM_Z6F-C6-200kg	TC2207 Rev.3
CAAPS4-300IG-RCE	300	50	1000	800x600	60	HBM_Z6F-C6-200kg	TC2207 Rev.3
CAAPS4-300II-RCE	300	50	1000	800x800	60	HBM_HLC B1-C6-220kg	TC6524 Rev.1
CAAPS4-300LI-RCE	300	50	1000	1000x800	60	HBM_HLC B1-C6-220kg	TC6524 Rev.1
CAAPS4-300LL-RCE	300	50	1000	1000x1000	60	HBM_HLC B1-C6-220kg	TC6524 Rev.1
CAAPS4-300NL-RCE	300	50	1000	1250x1000	60	HBM_HLC B1-C6-220kg	TC6524 Rev.1
CAAPS4-300NN-RCE	300	50	1000	1250x1250	60	HBM_HLC B1-C6-220kg	TC6524 Rev.1
CAAPS4-600IG-RCE	600	100	2000	800x600	50	HBM_Z6F-C6-200kg	TC2207 Rev.3
CAAPS4-600II-RCE	600	100	2000	800x800	120	HBM_HLC B1-C6-550kg	TC6524 Rev.1
CAAPS4-600LI-RCE	600	100	2000	1000x800	120	HBM_HLC B1-C6-550kg	TC6524 Rev.1
CAAPS4-600LL-RCE	600	100	2000	1000x1000	120	HBM_HLC B1-C6-550kg	TC6524 Rev.1
CAAPS4-600NL-RCE	600	100	2000	1250x1000	120	HBM_HLC B1-C6-550kg	TC6524 Rev.1
CAAPS4-600NN-RCE	600	100	2000	1250x1250	120	HBM_HLC B1-C6-550kg	TC6524 Rev.1
CAAPS4-600RN-RCE	600	100	2000	1500x1250	120	HBM_HLC B1-C6-550kg	TC6524 Rev.1
CAAPS4-600RR-RCE	600	100	2000	1500x1500	120	HBM_HLC B1-C6-550kg	TC6524 Rev.1
CAAPS4-600WR-RCE	600	100	2000	2000x1500	120	HBM_HLC B1-C6-550kg	TC6524 Rev.1
CAAPS4-1500II-RCE	1200	200	4000	800x800	240	HBM_HLC B1-C6-1100kg	TC6524 Rev.1
CAAPS4-1500LI-RCE	1200	200	4000	1000x800	240	HBM_HLC B1-C6-1100kg	TC6524 Rev.1
CAAPS4-1500LL-RCE	1200	200	4000	1000x1000	240	HBM_HLC B1-C6-1100kg	TC6524 Rev.1
CAAPS4-1500NL-RCE	1200	200	4000	1250x1000	240	HBM_HLC B1-C6-1100kg	TC6524 Rev.1
CAAPS4-1500NN-RCE	1200	200	4000	1250x1250	240	HBM_HLC B1-C6-1100kg	TC6524 Rev.1
CAAPS4-1500RN-RCE	1200	200	4000	1500x1250	240	HBM_HLC B1-C6-1100kg	TC6524 Rev.1
CAAPS4-1500RR-RCE	1200	200	4000	1500x1500	240	HBM_HLC B1-C6-1100kg	TC6524 Rev.1
CAAPS4-1500WR-RCE	1200	200	4000	2000x1500	240	HBM_HLC B1-C6-1100kg	TC6524 Rev.1
CAAPS4-3000II-RCE	3000	500	10000	800x800	600	HBM_HLC B1-C6-1100kg	TC6524 Rev.1
CAAPS4-3000LI-RCE	3000	500	10000	1000x800	600	HBM_HLC B1-C6-1100kg	TC6524 Rev.1
CAAPS4-3000LL-RCE	3000	500	10000	1000x1000	600	HBM_HLC B1-C6-1100kg	TC6524 Rev.1
CAAPS4-3000NL-RCE	3000	500	10000	1250x1000	600	HBM_HLC B1-C6-1100kg	TC6524 Rev.1
CAAPS4-3000NN-RCE	3000	500	10000	1250x1250	600	HBM_HLC B1-C6-1100kg	TC6524 Rev.1
CAAPS4-3000RN-RCE	3000	500	10000	1500x1250	500	HBM_HLC B1-C6-1100kg	TC6524 Rev.1
CAAPS4-3000RR-RCE	3000	500	10000	1500x1500	500	HBM_HLC B1-C6-1100kg	TC6524 Rev.1
CAAPS4-3000WR-RCE	3000	500	10000	2000x1500	300	HBM_HLC B1-C6-1100kg	TC6524 Rev.1



Dreibereichswaagen / Three range instruments**CAAPS1...-UCE**

Modell / Model X	Max (kg) ≤	e (g)	Min (g)	Abmess-ungen / Dimensions (mm) ≤	Einschaltnullstell- bereich + zusätzliche Totlast / Initial zero setting range + additional dead load (kg) ≤ ±	Wägezellenhersteller Und Wägezellen- kennzeichnung / load cell manufacturer and load cell marking	load cell Zertifikat Nr. / Certificate no.
	R1 R2 R3	R1 R2 R3	R1 R2 R3				
CAAPS1-6DC-UCE	1,5	0,5	10	320x240	1,2	Flintec_PC6-11kg-C3MI6	D09-00.02 Rev.7
	3	1	20				
	6	2	40				
CAAPS1-15DC-UCE	3	1	20	320x240	3	Flintec_PC6-22kg-C3MI6	D09-00.02 Rev.7
	6	2	40				
	15	5	100				
CAAPS1-30ED-UCE	6	2	40	400x300	6	Flintec_PC6-50kg-C3MI6	D09-00.02 Rev.7
	15	5	100				
	30	10	200				
CAAPS1-30FE-UCE	6	2	40	500x400	6	Flintec_PC6-50kg-C3MI6	D09-00.02 Rev.7
	15	5	100				
	30	10	200				
CAAPS1-60ED-UCE	15	5	100	400x300	12	Flintec_PC6-100kg-C3MI6	D09-00.02 Rev.7
	30	10	200				
	60	20	400				
CAAPS1-60FE-UCE	15	5	100	500x400	12	Flintec_PC6-100kg-C3MI6	D09-00.02 Rev.7
	30	10	200				
	60	20	400				
CAAPS1-150FE-UCE	30	10	200	500x400	30	Flintec_PC6-200kg-C3MI12	D09-00.02 Rev.7
	60	20	400				
	150	50	1000				



CAAPS4...-UCE

Modell / Model X	Max (kg) ≤	e (g)	Min (g)	Abmess-ungen / Dimensions (mm) ≤	Einschaltnullstell- bereich + zusätzliche Totlast / Initial zero setting range + additional dead load (kg) ≤ ±	Wägezellenhersteller Und Wägezellen- kennzeichnung / load cell manufacturer and load cell marking	load cell Zertifikat Nr. / Certificate no.
	R1 R2 R3	R1 R2 R3	R1 R2 R3				
CAAPS4-300GF-UCE	60	20	400	650x500	20	HBM_Z6F-C6-100kg	TC2207 Rev.3
	150	50	1000				
	300	100	2000				
CAAPS4-300IG-UCE	60	20	400	800x600	10	HBM_Z6F-C6-100kg	TC2207 Rev.3
	150	50	1000				
	300	100	2000				
CAAPS4-600IG-UCE	150	50	1000	800x600	50	HBM_Z6F-C6-200kg	TC2207 Rev.3
	300	100	2000				
	600	200	4000				
CAAPS4-1500II-UCE	300	100	2000	800x800	200	HBM_HLC B1-C6-550kg	TC6524 Rev.1
	600	200	4000				
	1500	500	10000				
CAAPS4-1500LI-UCE	300	100	2000	1000x800	200	HBM_HLC B1-C6-550kg	TC6524 Rev.1
	600	200	4000				
	1500	500	10000				
CAAPS4-1500LL-UCE	300	100	2000	1000x1000	200	HBM_HLC B1-C6-550kg	TC6524 Rev.1
	600	200	4000				
	1500	500	10000				
CAAPS4-1500NL-UCE	300	100	2000	1250x1000	200	HBM_HLC B1-C6-550kg	TC6524 Rev.1
	600	200	4000				
	1500	500	10000				
CAAPS4-1500NN-UCE	300	100	2000	1250x1250	200	HBM_HLC B1-C6-550kg	TC6524 Rev.1
	600	200	4000				
	1500	500	10000				
CAAPS4-1500RN-UCE	300	100	2000	1500x1250	100	HBM_HLC B1-C6-550kg	TC6524 Rev.1
	600	200	4000				
	1500	500	10000				
CAAPS4-1500RR-UCE	300	100	2000	1500x1500	100	HBM_HLC B1-C6-550kg	TC6524 Rev.1
	600	200	4000				
	1500	500	10000				
CAAPS4-3000II-UCE	600	200	4000	800x800	600	HBM_HLC B1-C6-1100kg	TC6524 Rev.1
	1500	500	10000				
	3000	1000	20000				
CAAPS4-3000LI-UCE	600	200	4000	1000x800	600	HBM_HLC B1-C6-1100kg	TC6524 Rev.1
	1500	500	10000				
	3000	1000	20000				
CAAPS4-3000LL-UCE	600	200	4000	1000x1000	600	HBM_HLC B1-C6-1100kg	TC6524 Rev.1
	1500	500	10000				
	3000	1000	20000				
CAAPS4-3000NL-UCE	600	200	4000	1250x1000	600	HBM_HLC B1-C6-1100kg	TC6524 Rev.1
	1500	500	10000				
	3000	1000	20000				
CAAPS4-3000NN-UCE	600	200	4000	1250x1250	600	HBM_HLC B1-C6-1100kg	TC6524 Rev.1
	1500	500	10000				
	3000	1000	20000				
CAAPS4-3000RN-UCE	600	200	4000	1500x1250	500	HBM_HLC B1-C6-1100kg	TC6524 Rev.1
	1500	500	10000				
	3000	1000	20000				
CAAPS4-3000RR-UCE	600	200	4000	1500x1500	500	HBM_HLC B1-C6-1100kg	TC6524 Rev.1
	1500	500	10000				
	3000	1000	20000				
CAAPS4-3000WR-UCE	600	200	4000	2000x1500	300	HBM_HLC B1-C6-1100kg	TC6524 Rev.1
	1500	500	10000				
	3000	1000	20000				



Zweiteilungswaagen / Two-interval instruments**CAAPS1...-MCE**

Modell / Model x	Max (kg) ≤	e (g)	Min (g)	Abmess- ungen / Dimensions (mm) ≤	Einschalt- nullstellbereich + zusätzliche Totlast / Initial zero setting range + additional dead load (kg) ≤ ±	Wägezellenhersteller u. Wägezellenkennzeichnung / load cell manufacturer and load cell marking	load cell Zertifikat Nr. / Certificate no.
CAAPS1-3DC-MCE	1,5	0,5	10	320x240	0,6	Flintec_PC6-11kg-C3MI6	D09-00.02 Rev.7
	3	1					
CAAPS1-6DC-MCE	3	1	20	320x240	1,2	Flintec_PC6-11kg-C3MI6	D09-00.02 Rev.7
	6	2					
CAAPS1-30ED-MCE	15	5	100	400x300	6	Flintec_PC6-50kg-C3MI6	D09-00.02 Rev.7
	30	10					
CAAPS1-30FE-MCE	15	5	100	500x400	6	Flintec_PC6-50kg-C3MI6	D09-00.02 Rev.7
	30	10					
CAAPS1-60ED-MCE	30	10	200	400x300	12	Flintec_PC6-100kg-C3MI6	D09-00.02 Rev.7
	60	20					
CAAPS1-60FE-MCE	30	10	200	500x400	12	Flintec_PC6-100kg-C3MI6	D09-00.02 Rev.7
	60	20					
CAAPS1-150FE-MCE	60	20	400	500x400	30	Flintec_PC6-200kg-C3MI12	D09-00.02 Rev.7
	150	50					

CAAPS4...-MCE

Modell / Model x	Max (kg) ≤	e (g)	Min (g)	Abmess- ungen / Dimensions (mm) ≤	Einschalt- nullstellbereich + zusätzliche Totlast / Initial zero setting range + additional dead load (kg) ≤ ±	Wägezellenhersteller u. Wägezellenkennzeichnung / load cell manufacturer and load cell marking	load cell Zertifikat Nr. / Certificate no.
CAAPS4-60GF-MCE	30	10	200	650x500	12	HBM_Z6F-C6-50kg	TC2207 Rev.3
	60	20					
CAAPS4-60IG-MCE	30	10	200	800x600	12	HBM_Z6F-C6-50kg	TC2207 Rev.3
	60	20					
CAAPS4-150GF-MCE	60	20	400	650x500	30	HBM_Z6F-C3MI 7500-100kg	TC2207 Rev.3
	150	50					
CAAPS4-150IG-MCE	60	20	400	800x600	30	HBM_Z6F-C3MI 7500-100kg	TC2207 Rev.3
	150	50					
CAAPS4-300GF-MCE	150	50	1000	650x500	60	HBM_Z6F-C6-200kg	TC2207 Rev.3
	300	100					
CAAPS4-300IG-MCE	150	50	1000	800x600	60	HBM_Z6F-C6-200kg	TC2207 Rev.3
	300	100					
CAAPS4-300II-MCE	150	50	1000	800x800	60	HBM_HLC B1-C6-220kg	TC6524 Rev.1
	300	100					
CAAPS4-300LI-MCE	150	50	1000	1000x800	60	HBM_HLC B1-C6-220kg	TC6524 Rev.1
	300	100					
CAAPS4-300LL-MCE	150	50	1000	1000x1000	60	HBM_HLC B1-C6-220kg	TC6524 Rev.1
	300	100					
CAAPS4-300NL-MCE	150	50	1000	1250x1000	60	HBM_HLC B1-C6-220kg	TC6524 Rev.1
	300	100					
CAAPS4-300NN-MCE	150	50	1000	1250x1250	60	HBM_HLC B1-C6-220kg	TC6524 Rev.1
	300	100					
CAAPS4-600IG-MCE	300	100	2000	800x600	50	HBM_Z6F-C6-200kg	TC2207 Rev.3
	600	200					
CAAPS4-600II-MCE	300	100	2000	800x800	120	HBM_HLC B1-C6-550kg	TC6524 Rev.1
	600	200					
CAAPS4-600LI-MCE	300	100	2000	1000x800	120	HBM_HLC B1-C6-550kg	TC6524 Rev.1
	600	200					
CAAPS4-600LL-MCE	300	100	2000	1000x1000	120	HBM_HLC B1-C6-550kg	TC6524 Rev.1
	600	200					
CAAPS4-600NL-MCE	300	100	2000	1250x1000	120	HBM_HLC B1-C6-550kg	TC6524 Rev.1
	600	200					

M11-007-001-01-de

08.06.2011

5/6

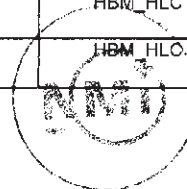

Fortsetzung / Continuation CAAPS4...-MCE

Modell / Model x	Max (kg) ≤	e (g)	Min (g)	Abmess- ungen / Dimensions (mm) ≤	Einschalt- nullstellbereich + zusätzliche Totlast / Initial zero setting range + additional dead load (kg) ≤ ±	Wägezellenhersteller u. Wägezellenkennzeichnung / load cell manufacturer and load cell marking	load cell Zertifikat Nr. / Certificate no.
CAAPS4-600NN-MCE	300	100	2000	1250x1250	120	HBM_HLC B1-C6-550kg	TC6524 Rev.1
	600	200					
CAAPS4-600RN-MCE	300	100	2000	1500x1250	120	HBM_HLC B1-C6-550kg	TC6524 Rev.1
	600	200					
CAAPS4-600RR-MCE	300	100	2000	1500x1500	120	HBM_HLC B1-C6-550kg	TC6524 Rev.1
	600	200					
CAAPS4-600WR-MCE	300	100	2000	2000x1500	120	HBM_HLC B1-C6-550kg	TC6524 Rev.1
	600	200					
CAAPS4-1500II-MCE	600	200	4000	800x800	300	HBM_HLC B1-C3 MI 7500-1100kg	TC6524 Rev.1
	1500	500					
CAAPS4-1500LI-MCE	600	200	4000	1000x800	300	HBM_HLC B1-C3 MI 7500-1100kg	TC6524 Rev.1
	1500	500					
CAAPS4-1500LL-MCE	600	200	4000	1000x1000	300	HBM_HLC B1-C3 MI 7500-1100kg	TC6524 Rev.1
	1500	500					
CAAPS4-1500NL-MCE	600	200	4000	1250x1000	300	HBM_HLC B1-C3 MI 7500-1100kg	TC6524 Rev.1
	1500	500					
CAAPS4-1500NN-MCE	600	200	4000	1250x1250	300	HBM_HLC B1-C3 MI 7500-1100kg	TC6524 Rev.1
	1500	500					
CAAPS4-1500RN-MCE	600	200	4000	1500x1250	300	HBM_HLC B1-C3 MI 7500-1100kg	TC6524 Rev.1
	1500	500					
CAAPS4-1500RR-MCE	600	200	4000	1500x1500	300	HBM_HLC B1-C3 MI 7500-1100kg	TC6524 Rev.1
	1500	500					
CAAPS4-1500WR-MCE	600	200	4000	2000x1500	300	HBM_HLC B1-C3 MI 7500-1100kg	TC6524 Rev.1
	1500	500					
CAAPS4-3000II-MCE	1500	500	10000	800x800	600	HBM_HLC B1-C6-1100kg	TC6524 Rev.1
	3000	1000					
CAAPS4-3000LI-MCE	1500	500	10000	1000x800	600	HBM_HLC B1-C6-1100kg	TC6524 Rev.1
	3000	1000					
CAAPS4-3000LL-MCE	1500	500	10000	1000x1000	600	HBM_HLC B1-C6-1100kg	TC6524 Rev.1
	3000	1000					
CAAPS4-3000NL-MCE	1500	500	10000	1250x1000	600	HBM_HLC B1-C6-1100kg	TC6524 Rev.1
	3000	1000					
CAAPS4-3000NN-MCE	1500	500	10000	1250x1250	600	HBM_HLC B1-C6-1100kg	TC6524 Rev.1
	3000	1000					
CAAPS4-3000RN-MCE	1500	500	10000	1500x1250	500	HBM_HLC B1-C6-1100kg	TC6524 Rev.1
	3000	1000					
CAAPS4-3000RR-MCE	1500	500	10000	1500x1500	500	HBM_HLC B1-C6-1100kg	TC6524 Rev.1
	3000	1000					
CAAPS4-3000WR-MCE	1500	500	10000	2000x1500	300	HBM_HLC B1-C6-1100kg	TC6524 Rev.1
	3000	1000					



Minebea Intec Bovenden GmbH & Co. KG
Leinetal 2
37120 Bovenden, Germany

Phone +49.551.309.83.0
Fax +49.551.309.83.190

www.minebea-intec.com

Copyright by Minebea Intec, Bovenden,
Germany.

No part of this publication may be
reprinted or translated in any form or
by any means without prior written
permission from Minebea Intec. All rights
reserved.

The status of the information,
specifications and illustrations in this
manual is indicated by the date given
below. Minebea Intec reserves the right to
make changes to the technology, features,
specifications, and design of the equipment
without notice.

Date: August 2019