

## NOTICE DURING INSTALLATION



Warning

Warning that causes injury or accident and develops into harm to the operator.  
Do not do these things described here.

In the case of carriage

- When you carry the instrument, check that there is no looseness at the fixed bolt on the guide plate. There may be fears of disassembly of the instrument or falling down of the accessories.
- It's strictly prohibited from lifting up the load cell cable, when you carry the instrument. There may be fears of cutting off the cable or falling down of the instrument.

Location to install

- When you install the instrument, be sure to work with full considerations on safety.
- Use the instrument where the temperature/humidity specifies within the range as follows:

Environmental temperature: -10°C to 70°C

Environmental humidity: Less than 85%RH

- When you install, tighten the bolts securely with consideration on deflection stay. If you neglect, there may be fears of deterioration in the specifications for the instrument.
- Don't weld the plate section of the instrument on the structures (beam, bracket and so on) together directly. There may be the fear of deterioration in the specifications for the instrument.
- Protect the load cell cable with the piping materials. Due to the external injury, chemicals and washing, there may be deterioration in insulation or cutting off the cable by the deterioration of cover.
- The clearance hole should be prepared for the bracket at the turnover preventing device of the instrument.
- Be sure to keep the instruction manual for the instrument, and also all of the removed parts at hand. They will become necessary when maintenance is required.

### Record of revision

Data	Instruction No.	Contents
AUG,2000	DRW.293-1008	First version
Nov,2010	DRW.293-1008A	FN10-02140
May,2012	DRW.293-1008B	FN12-01052

### Each name

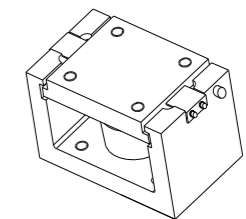
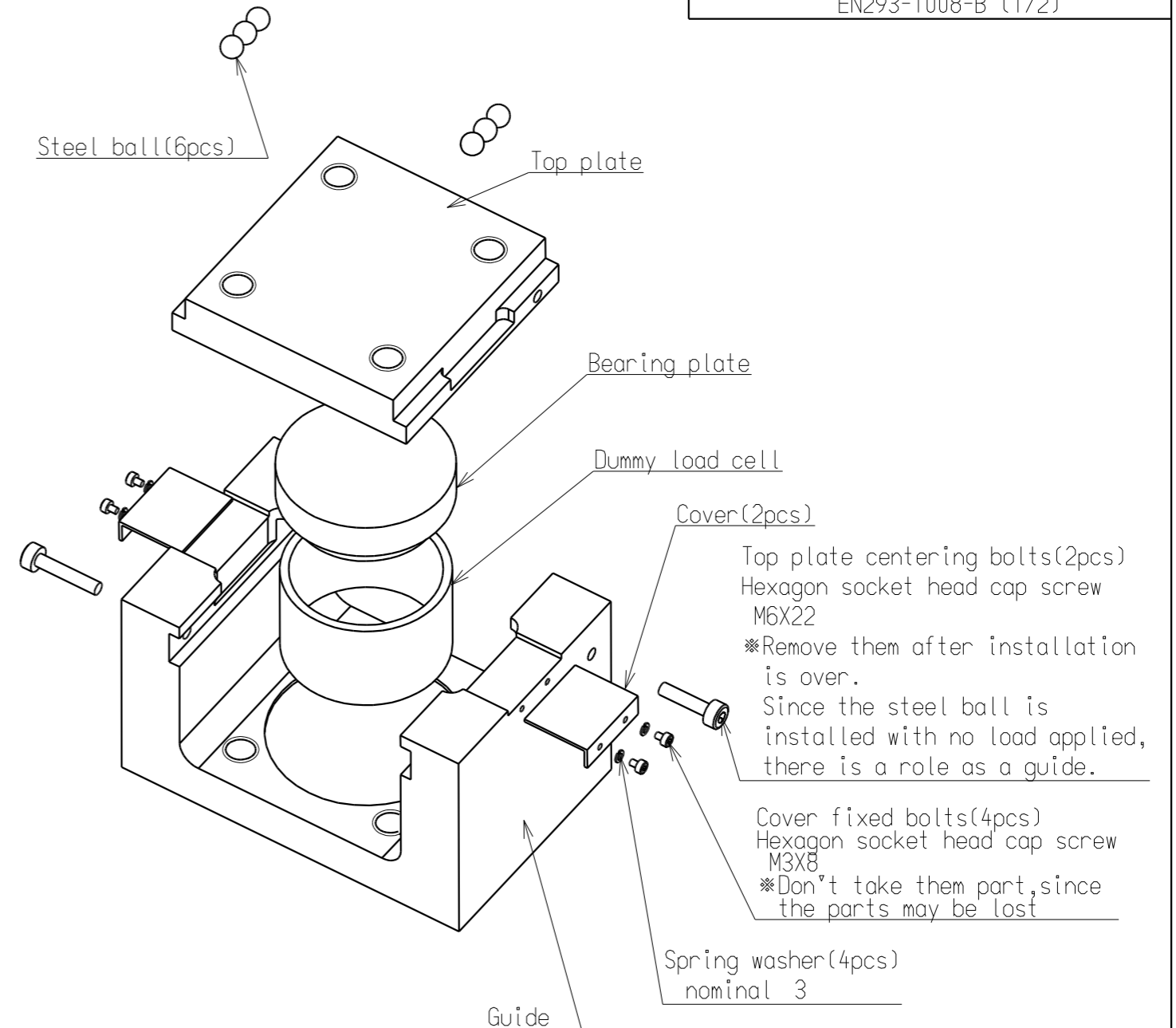

Package at the time of shipment

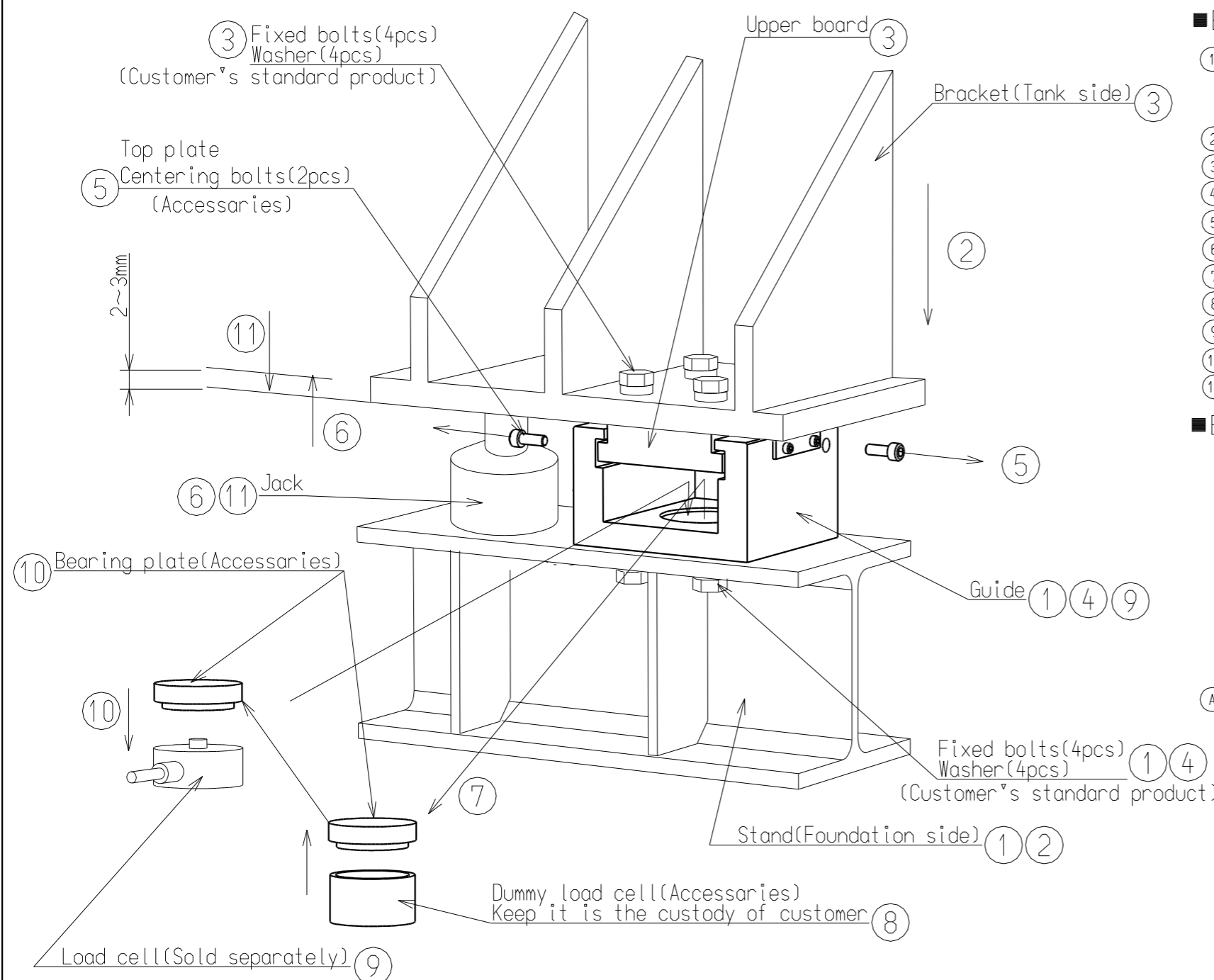

### ■ Example of installation procedures

- ① Fix the guide on the stand preliminarily.  
• The level on the upper surface of the stand should be within  $\pm 0.3$  deg.
- ② Lower the tank.
- ③ Fix the top plate to the bracket.
- ④ Fix the guide to the stand.
- ⑤ Remove the top plate centering bolt.
- ⑥ Lift up the tank approx. 3 or 3 mm with a jack.
- ⑦ Remove the bearing plate.
- ⑧ Remove the dummy load cell.
- ⑨ Place the load cell on the guide.
- ⑩ Put the bearing plate on the load cell.
- ⑪ Lower the tank slowly.

### ■ Example of adjustment procedures

After installing the instrument, make adjustment on the installation as follows:

#### Ideal Condition

- At the time of tare weight load application, controls the output of each load cell less than 30% (standard) of deviation against the equal division.
- However, if the position of center of gravity is deviated from the center of supporting point extremely, it will be out of that limitation.
- Set the steel ball with the condition of no load applied.

#### Ⓐ Level adjustment procedures

##### • What is "Level adjustment"?

To adjust the tare weight (Weight of tank) so that the each load cell shall weight equally.

##### • Liner adjustment

Insert some liners at the section of load cell whose division of tare weight portion is low.

Prepare for some liner. (0.1, 0.2, 0.5 and 1 mm)

Procedures: Check on the tare division.

Lift the tank up with a jack.

Loosen the fixed bolts located at the bracket side.

Insert the liners between the bracket and the top plate.

Then lower the tank.

Tighten the fixing bolts at the side of bracket.

#### Ⓑ Adjustment on no load application on steel ball

- Reason: If some load is applied on the steel ball, there may have a fear of effect on accuracy.
- Check method: Check that there are equal clearances between the top plate and the guide, and right and left with the eye.
- Adjustment procedures: Loosen the fixed bolts at the side of bracket. Adjust the clearance by sliding the top plate. Tighten up the fixed bolts and adjust the clearance. Tighten up the fixed bolts at the side of bracket.
- Remarks: You can adjust surely when 2 pcs of jigs are prepared as shown in the fig.

