

Minebea

***Summing type Junction box
SB-320***

Instruction Manual

Introduction

Thank you very much for your purchasing our Summing type Junction box SB-320.
Use properly after reading through the manual carefully.
Moreover, the end user should keep the manual at hand after reading over.

Marks and arrangements used in this manual

The following marks are attached to the explanation on the matters that indicate
” Don’t do this.”, ”Take care.” and ”For reference.”

Be sure to read these items where these marks are attached.



WARNING

- **Warning causes injury or accident that may develop into harm to the operator.
Don't do these things as described here.**



- **Notice and limitation during operation and working.
Be sure to read the item not to make a mistake.**

Safety Precautions

Please be sure to read this manual before attempting to use the equipment.

1. Installation location



· Use the instrument where the temperature/humidity specifies within the range as follows.

- Environmental temperature: — 10°C to 70°C
- Environmental humidity: 20% to 80% (Non-condensing)

When deterioration of insulation is considered due to wide range of environmental temperature change, fill the instrument with white vaseline after cable connection is completed.(Dryer will do.)

2. Places where installation is not allowed.



WARNING

· Do not locate the instrument on the places such as follows:
It causes unexpected faulty in the instrument.

- Don't locate the instrument where the direct sunshines applied.
- Do not use the instrument where waves or strong jet stream may splash directly.
- Do not install the instrument where mechanical vibration may exist a lot.
- Do not install the instrument where abrupt temperature change and humidity change may exist.
- Do not install the instrument near the devices that become magnetized or generate an electromagnetic field.
- Avoid the location where chemical reaction may cause such as in a laboratory or like that.

3. Matters that require attention in case of installation



WARNING

· These are matters that require attention in case of installation, so be sure to read them.

- When the instrument is installed outdoors, set the upper cover to the upward or in the vertical direction. And when vertical installation is required, set the instrument in the status that the cable gland or drawing direction of gland for piping should be parallel with the ground.
- When installing the instrument, fix it tightly with the screws.

Revision History

Date	Manual No.	Revision reason (details)
FEB, 2015	DRW.NO.EN294-1085	First version
NOV,2017	DRW.NO.EN294-1085A	Due to ECN FN17-02017 •Delete the company name in the contents. Due to ECN FN17-02181 •Correction 4-1. Weight [2.5 kg] to [6.7 kg]

Contents

	Page
Introduction.....	I
Marks and arrangements used in this manual.....	I
Safety Precautions	II
1. Installation location	II
2. Places where installation is not allowed.....	II
3. Matters that require attention in case of installation.....	III
Revision History	IV
1. General	1
1-1. General.....	1
1-2. Features.....	1
2. Installation procedures	2
2-1. Installation place	2
2-2. Places where installation is not allowed.....	2
2-3. Notice in case of installing the instrument.....	3
2-4. Installation procedures.....	3
3. Connections and terminal board	4
3-1. Connections.....	4
3-2. List of terminal board number, signal name, and our cable color.....	6
3-3. Note for installing terminal board	6
3-4. Fixing the cable.....	6
3-5. Fixing the upper cover	6
4. Specifications	7
4-1. General specifications.....	7
4-2. Outline dimensions	7
4-3. Warranty	7

1. General

1-1. General

When measurement is made with several pieces of strain gage applied transducers, this Summing type Junction box SB-320 can be connected between the amplifier.

Electrical signals detected from the transducer can be added with parallel and average output value can be obtained.

1-2. Features

- ① Dust-proofed, water-proofed constructions

Protective constructions : IP67

- ② Possibilities of piping

In case of application of SB-320-B type, piping is possible due to piping gland (PF1/2) is applied.

2. Installation procedures

2-1. Installation place



· Use the instrument where the temperature/humidity specify within the range as follows.

- Environmental temperature: -10°C to 70°C
- Environmental humidity: 20 % to 80 % (Non-condensing.)

When deterioration of insulation is considered due to wide range of environmental temperature change, fill the instrument with white vaseline after cable connection is completed.
(Dryer will do.)

2-2. Places where installation is not allowed.



WARNING

· Don't locate the instrument on the places such as follows :
It may cause unexpected faulty in the instrument.

- Don't locate the instrument where the direct sunshines are applied.
- Don't use the instrument where waves or strong jet stream may splash directly.
- Don't install the instrument where mechanical vibration may exist a lot.
- Don't install the instrument where abrupt temperature change and humidity change may exist.
- Don't install the instrument near the devices that become magnetized or generate an electromagnetic field.
- Avoid the location where chemical reaction may cause such as in a laboratory or like that.

2-3. Notice in case of installing the instrument



· Followings are descriptions on notice in case of installation, so be sure to read them.

- When the instrument is installed in outdoors, be sure to locate with the upper cover upward or in the vertical direction. And when vertical installation is required, set the instrument in the status that the cable gland or drawing direction of gland for piping should be parallel with the ground.
- When installing the instrument, fix it tightly with the screws.

2-4. Installation procedures

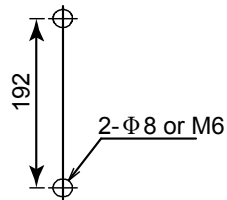

3. Connections and terminal board

3-1. Connections

① Pass the cable through the cable gland or gland for piping as the below figure indicates.

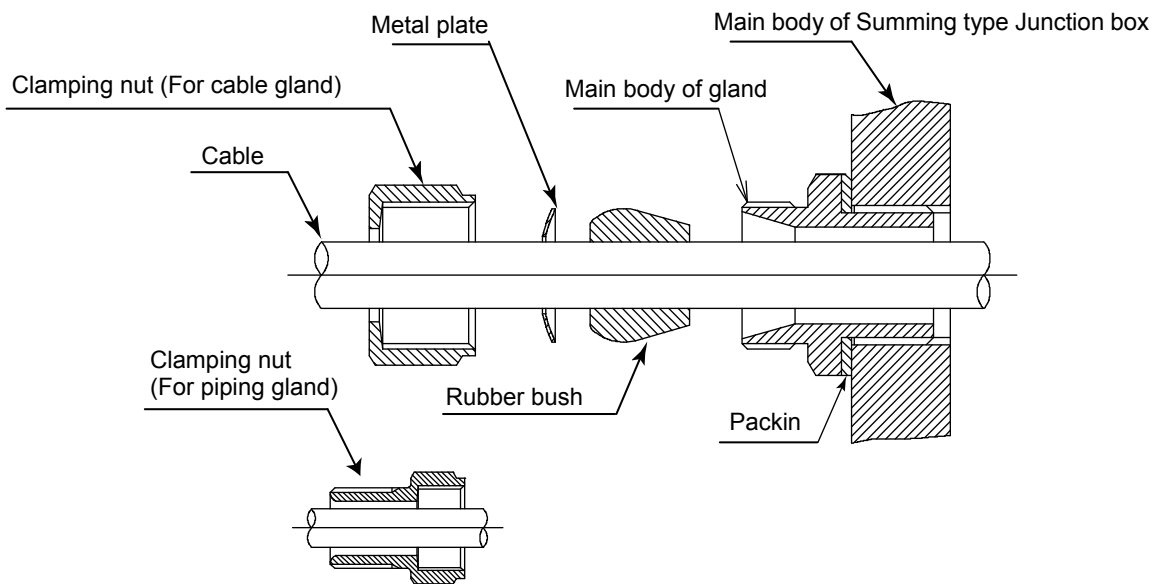

Note) In case of application of SB-320-B type, only the clamping nut will become as the above figure indicates.

② Piping should be made on the internal terminal board as the below figure indicates.

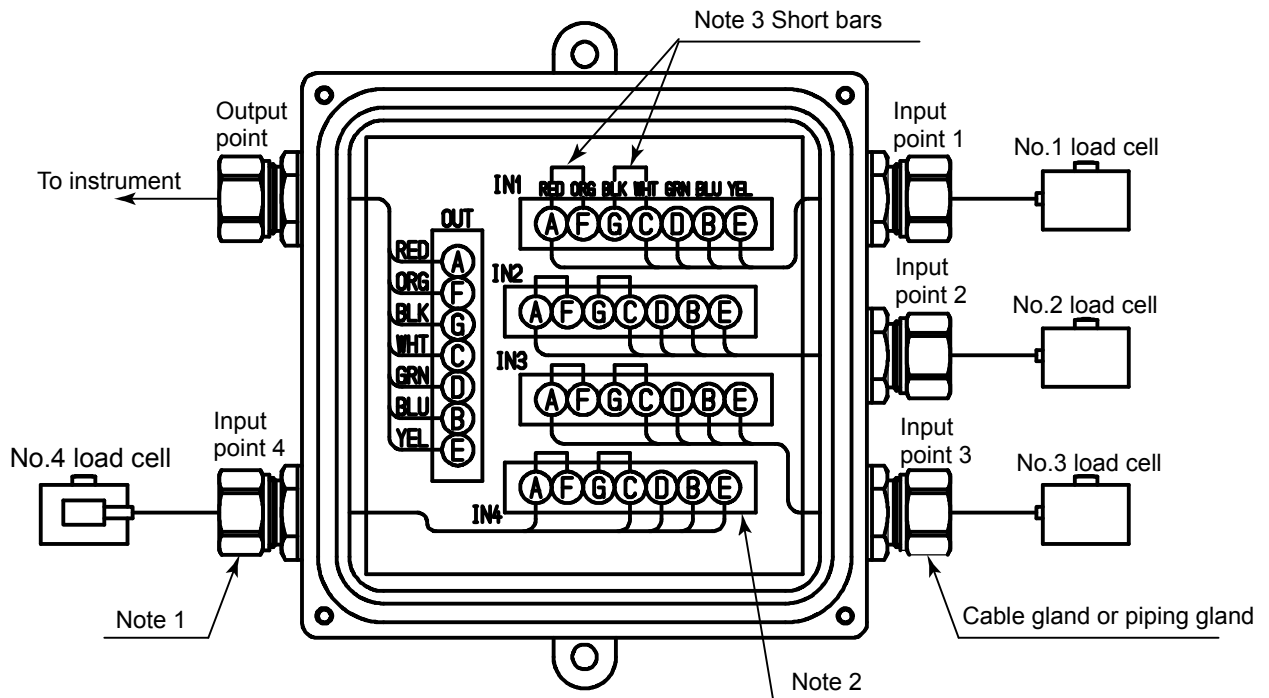

Note 1) In case of 3 points of application, input point 4 is seal plug.

Note 2) In case of 3 points of application, there is no terminal board of IN4.

Note 3) In case of application of 6 core shield cable, remove each short bar between A and F terminal, and C and G terminal. Moreover, in case of application of 4 core shield cable, use it after shortening between A and F terminal, and C and G terminal.

3-2. List of terminal board number, signal name, and our cable color

Terminal board NO.		Cable color	Signal name	Terminal board NO		Cable color	Signal name
A	RED	red	Input voltage (+)	D	GRN	green	Output voltage (+)
F	ORG	orange	Remote sensing (+)	B	BLU	blue	Output voltage (-)
G	BLK	black	Remote sensing (-)	E	YEL	yellow	Shield
C	WHT	white	Input voltage (-)				

3-3. Note for installing terminal board

Recommended torque for clamping torque for terminal screw on the terminal board specifies 5kg-cm. Moreover, suitable solderless terminals are as follows:

A: 3.2 mm or more
B: 7.0 mm or less

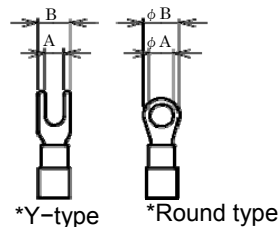

3-4. Fixing the cable

After piping is completed, fix the cable gland or clamping nut for piping gland in order to tighten the cable. Clamping should be applied until the clamping nut will not turn, or clamp with the torque that specifies 150 kgf-cm to 200 kgf-cm.

3-5. Fixing the upper cover

After fixing the cable, tighten the upper cover with hexagon socket head cap screws(M5). Clamping should be made with the clearance of 1mm between the main body of case and upper cover and 4 corners individually.



- In case of installing the upper cover, check that the Oring is fixed securely to the channel of main body of the case.

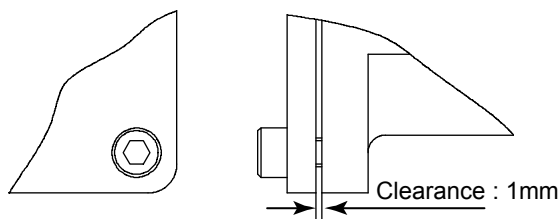

4. Specifications

4-1. General specifications

Protective constructions	:IP67
No. of addition points	:3 points or 4 points
Applicable cable diameter	: $\phi 3$ to $\phi 7$ (Internal diameter of gasket is $\phi 7$.) $\phi 7$ to $\phi 11$ (Internal diameter of gasket is $\phi 11$.)
Operating temperature/humidity range	:-10 to 70°C, 20 to 80 %R.H.(Non-condensing.)
Materials of the case	: SPS-13 (SUS 304 or equivalent.)
Weight	:6.7 kg approx.

4-2. Outline dimensions

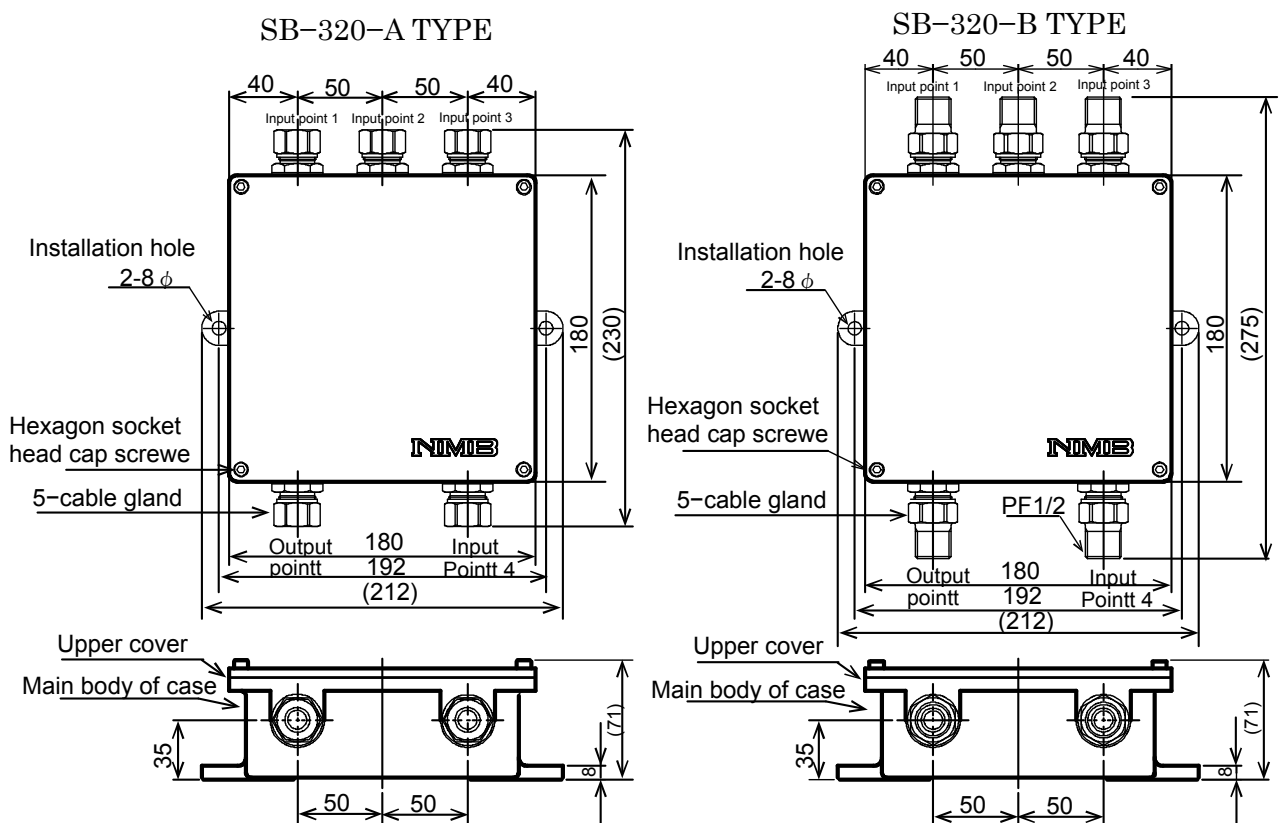

Unit : mm

4-3. Warranty

- 1) The instrument is covered by a warranty for a period of one year from the date of delivery.
- 2) As for repairs of after-service is required during the period of warranty, please contact with our sales office or sales agency from which you purchased.

●The contents of this manual may subject to change without notice.

HEAD QUARTER: **MinebeaMitsumi Inc.**

4106-73 Miyota, Miyota-machi, Kitasaku gun, Nagano-ken 389-0293 Japan
Tel: +81-267-32-2200 Fax: +81-267-31-1350

Sensing Device Product Sales Management:

1-1-1, Katase, Fujisawa-shi, Kanagawa-ken, 251-8531 Japan
Tel: +81-466-23-2681 Fax: +81-466-22-7191

Sensing Device Business Unit

FUJISAWA PLANT 1-1-1, Katase, Fujisawa-shi, Kanagawa-ken, 251-8531 Japan
Tel: +81-466-22-7151 Fax: +81-466-22-1701

KARUIZAWA PLANT 4106-73 Miyota, Miyota-machi, Kitasaku gun, Nagano-ken 389-0293 Japan
Tel: +81-267-31-1309 Fax: +81-267-31-1353

HOME PAGE ADDRESS <http://www.minebea-mcd.com>