

Minebea

*Summing type Junction box
SB-321*

Instruction Manual

Forward

Thank you very much for your purchasing the summing type junction box SB-321. This manual explains operating method and important notices in the case of using SB-321. Since misoperation might cause unexpected faulty, be sure to read this manual before use for the purpose of using this machine properly and safely.

Moreover, the end user should keep the manual at hand after reading it over.

Marks and arrangements used in this manual

The following marks are attached to the explanation on the matters that indicate “Don’t do this.”, “Take care.” and “For reference.”

Be sure to read these marks where these marks are attached.



Warning

Warning causes injury or accident that may develop into harm to the operator.
Don't do these things described here.



Notice and limitation during operation and working.
Be sure to read the item not to make a mistake.

- The contents of the manual may subject to change without notice.

For safe operation

(1) Installation place



Use the instrument where the temperature and humidity specify within the range as follows :

- Environmental temperature : $-10\text{ }^{\circ}\text{C}$ to $70\text{ }^{\circ}\text{C}$

When deterioration of insulation is considered due to wide range of environmental temperature change, fill the instrument with white Vaseline after cable connection is completed. (Dryer will do.)

(2) Location where installation is not allowed.



Do not locate the instrument on the places such as follows: It cause unexpected faulty in the instrument.

Warning

- Do not locate the instrument in direct and/or high temperature area.
- Please avoid to use in the place with the possibility of going under water.
- Do not install the instrument where there are vibrations and shocks.
- Do not use the instrument where there is excess of dusts and fine particles.
- Do not install the instrument where there is rapid change of temperature and humidity.
- Do not install the instrument near the devices that are magnetized or generate an electromagnetic field.
- Do not install the instrument where the instrument may be affected by radioactivity or radial rays.
- Avoid the location where chemical reaction may take place such as in a laboratory, or like that.

(3) Matter that require attention in case of installation



These are matters that require attention in case of installation, so be sure to read them.

- When the instrument is installed outdoors, set the upper cover to the upward or in the vertical direction. And when vertical installation is required, set the instrument in the status that the cable gland or drawing direction of gland for piping should be parallel with the ground.
- When installing the instrument, fix it tightly with the screws.
- Please close the hole of cable ground not used with the ground gasket or ground washer without a hole when you use it by summing in two or three points.

Record of revision

Date	Instruction manual	Revised reason(Contents)
2014/1	DRW. NO.294-1662	First version
2014/4	DRW.NO.294-1662A	FN14-01018 •Protective constructions change:IP68 → IP69K
2014/4	DRW.NO.294-1662B	FN14-01022 •Clerical error correction •Deletion and change of contents which do not suit on use.
2014/5	DRW.NO.294-1662C	FN14-01030 •Ground Packing(Inside diameter ϕ 9) addition. •Notes are added when using it by summing in two or three points. •English is added. •Material of packing is specified.
2016/06	DRW.NO.294-1662D	FN16-02057 •Delete 'Minebea Co.,LTD. Measuring Components Business Unit' from the front cover.
2017/09	DRW.NO.294-1662E	Due to ECN FN17-02017 •Delete the company name in the contents.

Contens

FORWARD.....	I
MARKS AND ARRANGEMENTS USED IN THIS MANUAL	I
FOR SAFE OPERATION	II
(1)INSTALLATION PLACE.....	II
RECORD OF REVISION.....	III
1. GENERAL	1
1-1. GENERAL.....	1
1-2. FEATURES.....	1
2. INSTALLATION PROCEDURES.....	2
2-1. INSTALLATION PLACE.....	2
2-2. PLACES WHERE INSTALLATION IS NOT ALLOWED/.....	2
2-3. NOTICE IN CASE OF INSTALLING THE INSTRUMENT	2
2-4. INSTALLATION PROCEDURES.....	3
3. CONNECTIONS AND TERMINAL BOARD.....	3
3-1. CONNECTIONS	3
3-2. LIST OF TERMINAL BOARD NUMBER, SIGNAL NAME, AND MINEBEA'S CABLE COLOR.....	4
3-3. NOTE FOR INSTALLING TERMINAL BOARD	5
3-4. FIXING THE CABLE	5
3-5. FIXING THE LID	5
4. SPECIFICATIONS.....	6
4-1. GENERAL SPECIFICATIONS	6
4-2. OUTLINE DIMENSIONS	6
4-3. WARRANTY	6

1. General

1-1.General

When measurement is made with several pieces of strain gage applied transducers, this Summing type Junction box SB-321 can be connected between the amplifiers.

Electrical signals detected from the transducer can be added with parallel and average output value can be obtained.

1-2.Features

- ① Dust-proofed, water-proofed constructions
Protective constructions: IP69K

- ② All stainless steel structure.

2. Installation procedures

2-1. Installation place



• Use the instrument where the temperature/humidity specify within the range as follows.

- Environmental temperature: $-10\sim 70^{\circ}\text{C}$

When deterioration of insulation is considered due to wide range of environmental temperature change, fill the instrument with white Vaseline after cable connection is completed. (Dryer will do.)

2-2. Places where installation is not allowed/



Warning

• Don't locate the instrument on the place such as follows: It may cause unexpected faulty in the instrument.

- Do not locate the instrument in direct and/or high temperature area.
- Please avoid to use in the place with the possibility of going under water.
- Do not install the instrument where there are vibrations and shocks.
- Do not use the instrument where there are corrosive gas and salt and like that.
- Do not install the instrument where there is rapid change of temperature and humidity.
- Do not install the instrument near the devices that are magnetized or generate an electromagnetic field.
- Do not install the instrument where the instrument may be affected by radioactivity or radial rays.
- Avoid the location where chemical reaction may take place such as in a laboratory, or like that.

2-3. Notice in case of installing the instrument



Following are descriptions on notice in case of installation, so be sure to read them.

- When the instrument is installed outdoors, set the upper cover to the upward or in the vertical direction. And when vertical installation is required, set the instrument in the status that the cable gland or drawing direction of gland for piping should be parallel with the ground.
- When installing the instrument, fix it tightly with the screws.
- Please close the hole of cable ground not used with the ground gasket or ground washer without a hole when you use it by summing in two or three points.

2-4. Installation procedures

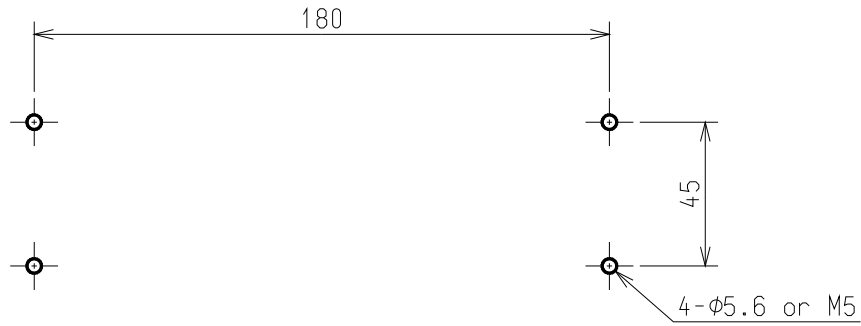

3. Connections and terminal board

3-1. Connections

- ① Pass the cable through the cable gland or gland for piping as the below figure indicates.

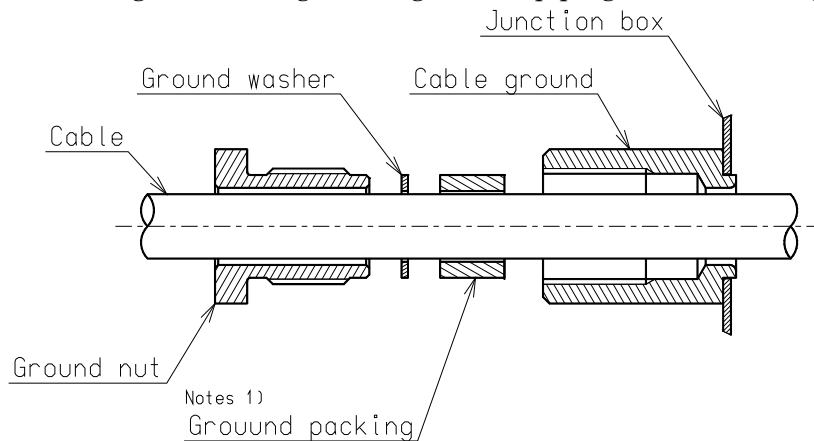

Notes 1) According to the diameter of a cable, as shown in the following table, please use the ground packing property.

Diameter of cable	Packing inside diameter
From more than $\phi 9$ to $\phi 11$	$\phi 11$
From more than $\phi 7$ to $\phi 9$	$\phi 9$
From $\phi 4.7$ to $\phi 7$	$\phi 7$



Please apply the ground gasket suitable for the diameter of the cable.

- ② When you use it by two points or three points, please carry out a cable ground part, as shown in the following figure.

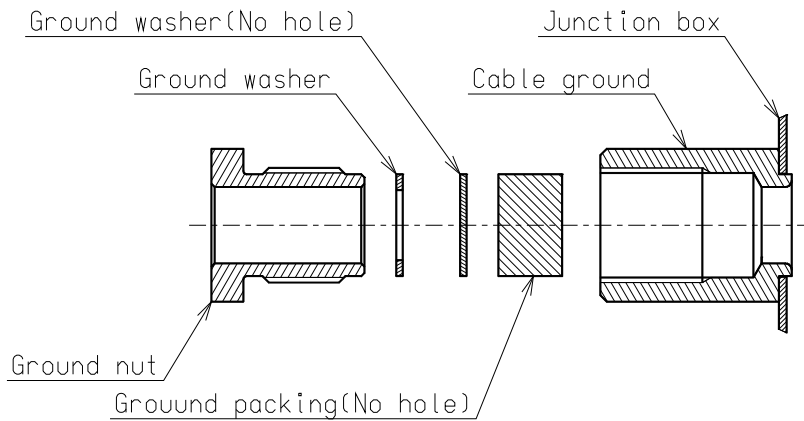

Please close the cable ground not used with a ground gasket or a ground washer without a hole.

- ③ Piping should be made on the internal terminal board as the below figure indicates.

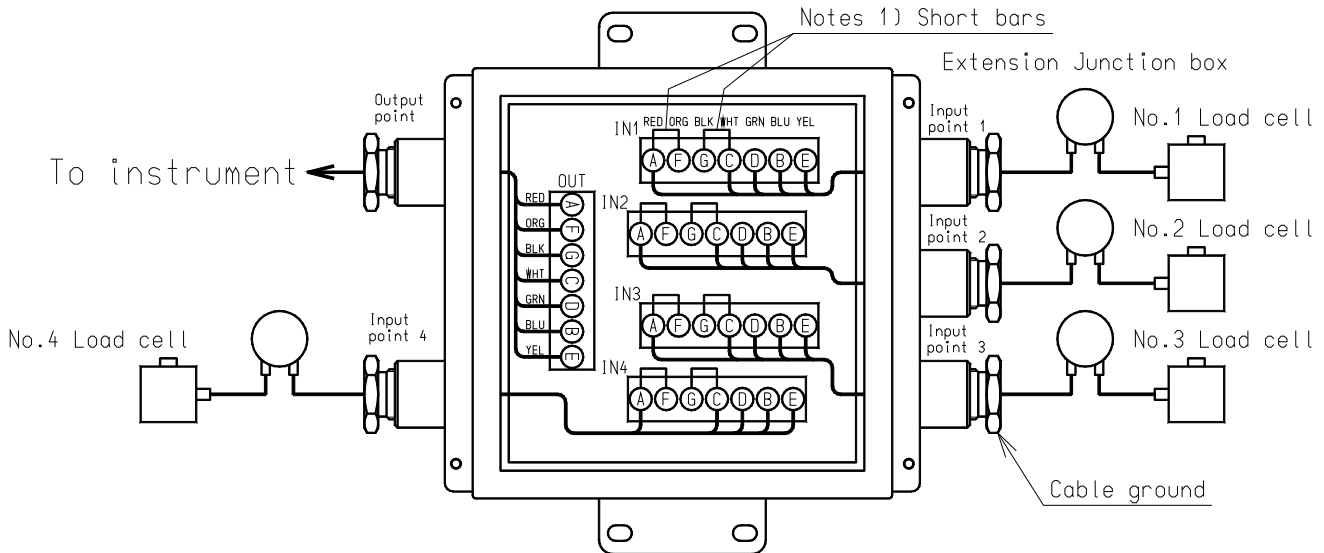

Notes1) Refer to the following table for connection of a short bar.

The cable on the meter side	The cable on the load cell side	Existence of a short bar
6 core shield cable	6 core shield cable	Please remove
6 core shield cable	4 core shield cable	Please do not remove
4 core shield cable	4 core shield cable	Please do not remove



When the cable of the strain gage applied transducer is extended, extension junction box is sued.

3-2. List of terminal board number, signal name, and cable color

Terminal board No.	Cable color	Signal name	Terminal board No.	Cable color	Signal name
A	RED	Red	D	GRN	Green
F	ORG	Orange	B	BLU	Blue
G	BLK	Black	E	YEL	Yellow
C	WHT	White			
		Input voltage(+)			Output voltage(+)
		Sensing(+)			Output voltage(-)
		Sensing(-)			Shield
		Input voltage(-)			

3-3. Note for installing terminal board

Recommended torque for clamping torque for terminal screw on the terminal board specifies 5kgf·cm.

Moreover, suitable solder less terminal are as follows:

A: 3.2mm or more

B: 7.0mm or less

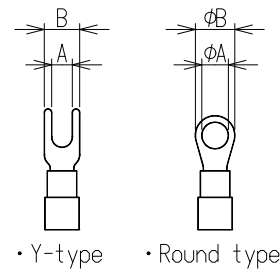

3-4. Fixing the cable

After wiring is completed, fix gland nut for cable gland in order to tighten the cable.

Clamping should be applied until the gland nut will not turn, or clamping with the torque that specifies 150 to 200 kgf·cm.

3-5. Fixing the lid

After fixing the cable, tighten the lid with hexagon socket head cap screws (M4).

Clamping should be applied clamping with the torque that specifies 16 to 20 kgf·cm.



When you bind a lid tight, check that packing is caught between a case and a lid.



When you bind a bolt tight, four bolts are tightened gradually.

4. Specifications

4-1. General specifications

Protective constructions	: IP69K
Addition points	: Max 4 points
Applicable cable diameter	: $\phi 4.7$ to $\phi 11$
Operating temperature	: -10 to 70°C
Materials of the case	: Stainless steel
Materials of the packing	: Synthetic rubber
Weight	: 1.7 kg approx

4-2. Outline dimensions

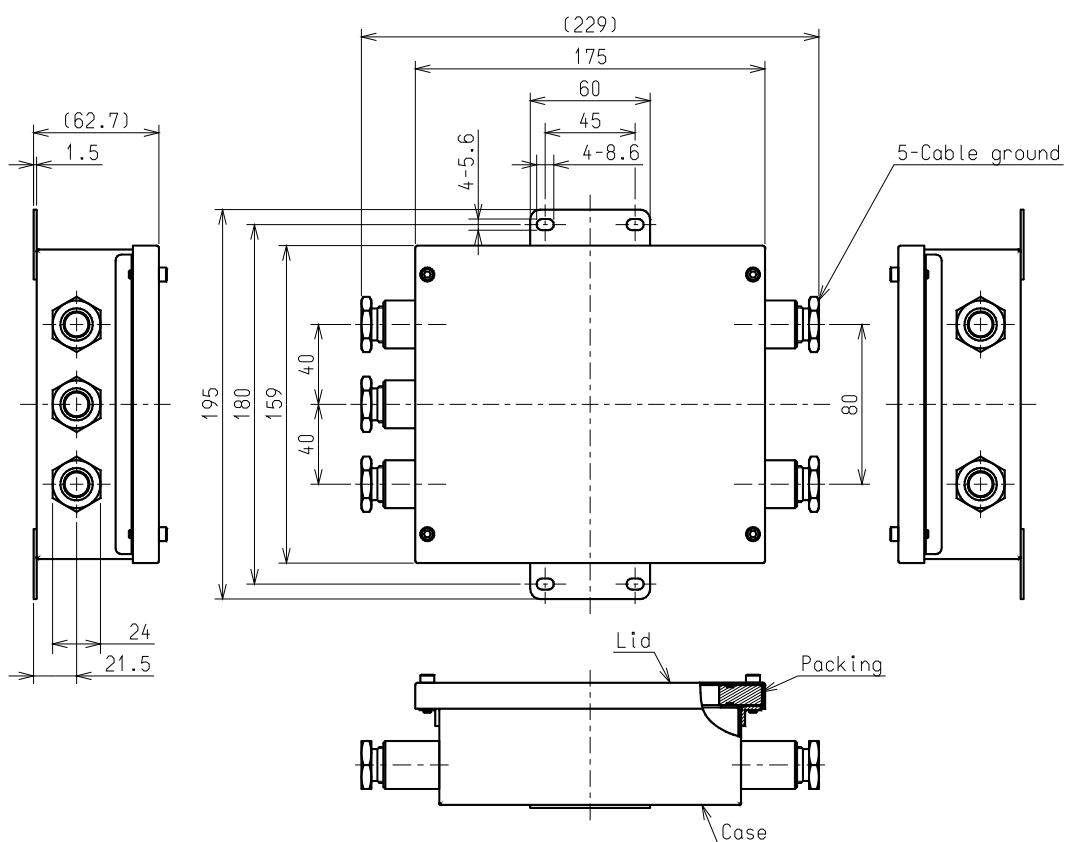

4-3. Warranty

The instruments are covered by a warranty for a period of one year from the date of delivery.

As for a repair of after-service is required during the period of warranty, please contact with our sales office or sales agency from which you purchased.

●The contents of this manual may subject to change without notice.

HEAD QUARTER: **MinebeaMitsumi Inc.**

4106-73 Miyota, Miyota-machi, Kitasaku gun, Nagano-ken 389-0293 Japan
Tel: +81-267-32-2200 Fax: +81-267-31-1350

Sensing Device Product Sales Management:

1-1-1, Katase, Fujisawa-shi, Kanagawa-ken, 251-8531 Japan
Tel: +81-466-23-2681 Fax: +81-466-22-7191

Sensing Device Business Unit

FUJISAWA PLANT 1-1-1, Katase, Fujisawa-shi, Kanagawa-ken, 251-8531 Japan
Tel: +81-466-22-7151 Fax: +81-466-22-1701

KARUIZAWA PLANT 4106-73 Miyota, Miyota-machi, Kitasaku gun, Nagano-ken 389-0293 Japan
Tel: +81-267-31-1309 Fax: +81-267-31-1353

HOME PAGE ADDRESS <http://www.minebea-mcd.com>