

Freefall metal detection system Vistus® with separator SW

The solution for high product throughput



ⓘ Separator SW benefits

- For high product throughput: the design successfully prevents the product from being crushed, increasing quality standards

ⓘ Benefits of Vistus® technology

- Maximum detection sensitivity
- True In-Process Validation
- Compact enough to be used in even the tightest of spaces
- Easy installation and operation



The innovative Freefall Metal Detection System Vistus®, in combination with the separator SW, ensures reliable detection of metal foreign bodies without crushing the product, while maintaining a high product throughput.

Perfected for maximum safety

- ⓘ The freefall metal detection system Vistus® offers maximum detection performance for the food industry. All **metal foreign bodies, including ferrous and non-ferrous metals and even non-magnetic stainless steels**, are consistently detected and separated from the production line.
- ⓘ The optional **True In-Process Validation** guarantees **authentic performance validation** – in the centre of the search coil and while the process is running.
- ⓘ **Space-saving product components** and a **reduced metal-free zone** make applications in the tightest of space possible.
- ⓘ When combined with the **separator SW**, Vistus® is the optimal solution for **high product throughput**. Swivelling the pipe segment out effectively prevents the product from being crushed.

Freefall Metal Detection System Vistus® with separator SW

The separator SW is used to configure your Freefall System Vistus® specifically for high product throughput applications. Swivelling the pipe segment out effectively prevents the product from being crushed, ensuring even higher product quality. By choosing the specially-designed combination of search coil, pipe and optional True In-Process Validation, you can customise your metal detection system to meet your specific needs.

Control unit

Vistus® E operator terminal
Scale drawing

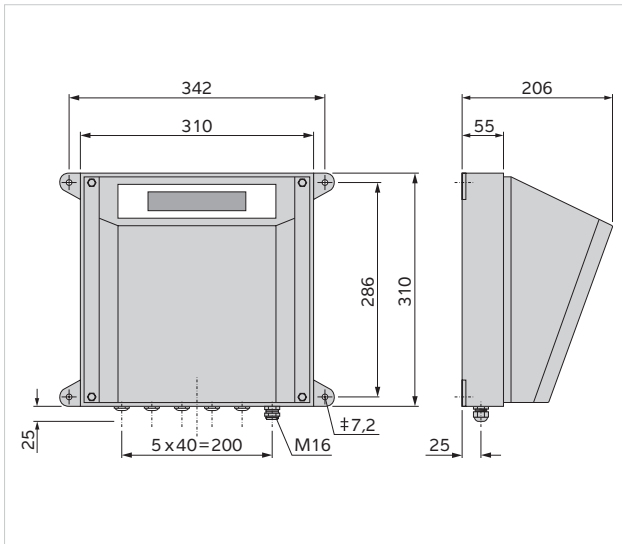

One control unit is suitable for connecting up to four search coils.

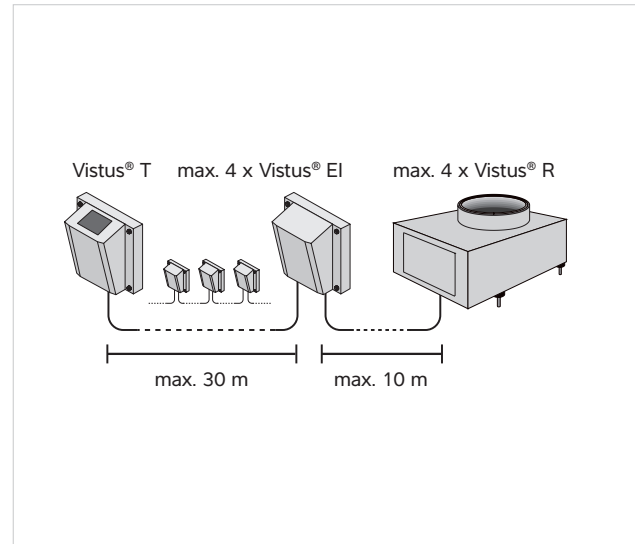

Search coil options

Vistus® R search coil
Scale drawing

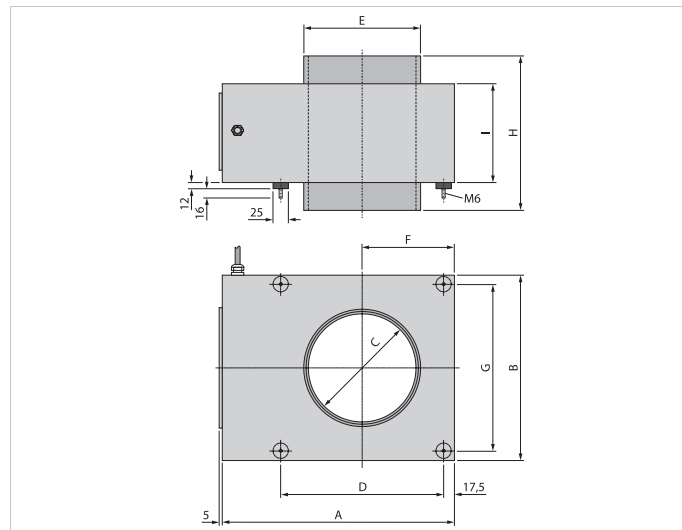

Coil dimensions

Vistus® R	A	B	C	D	E	F	G	H	I	kg
2.8	289	195	28	160	39.5	97.5	160	175	160	12
5.9	289	195	59	160	70.5	97.5	160	185	160	10.7
8.4	289	195	84	160	97.5	97.5	160	195	160	9.2
12	289	195	120	160	132.5	97.5	160	205	160	7.7
17.2	393	300	172	256	187.5	150	265	250	160	16.5
21.6	393	300	216	256	232.5	150	265	260	160	14.6
26.9	523	430	269	359	288	215	395	310	200	28
34.1	523	430	341	359	363	215	395	320	200	30

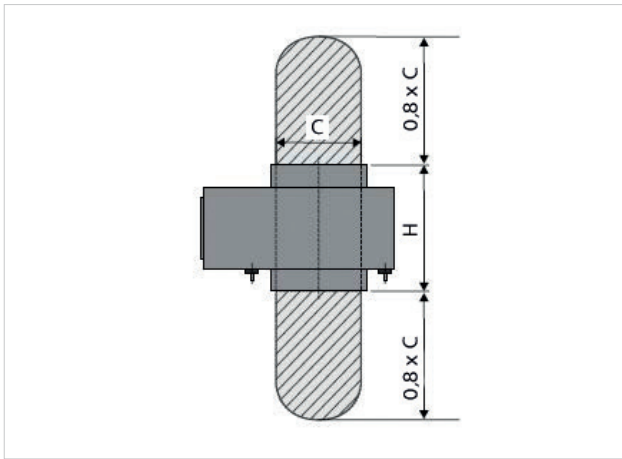

Metal-free zone Vistus® R

If moving parts made from aluminium or stainless steel (VA 1.4301), such as the scale pans on a bagging machine, are operated in front of the Vistus® R, 0.8 times the passage height must be maintained as a metal-free zone above and below the metal detector.

Throughputs

Different designs of the freetail metal detection system Vistus® are available.

Freetail pipe with separator			
Nominal width NW in mm, Separator	Diameter Di in mm, freetail pipe	Metal detector opening	Throughput kg/h
Vistus®-TCU-SW 4	NW 40	5.9	1,350
Vistus®-TCU-SW 5	NW 50	8.4	1,500
Vistus®-TCU-SW 10	NW 100	12	6,000
Vistus®-TCU-SW 15	NW 150	17.2	13,500
Vistus®-TCU-SW 19	NW 190	21.6	24,000

The effective throughput depends on the flow characteristics and density of the product. The values in the table refer to a density of $\rho=1000 \text{ kg/m}^3$. If the product's flow characteristics are optimal, the guide values can be exceeded by 50 %.

Pipe quality options

Various materials are available for the freetail pipe of the metal detector:

PP – standard polypropylene pipe: suitable for detection of foreign bodies in products that do not generate static electricity. Universal solution for products that are not susceptible to electrical discharge. Outer graphite coating for static discharge.

ESD: meets food safety requirements thanks to health clearance as per EU regulations (nos 10/2011 and 1935/2004). The ESD pipe continually neutralises static charging.

Ceramic: for applications with product temperatures up to 150 °C (available upon request).

		Pipe material		
		PP graphite-coated	ESD	Ceramic
Product temperature $\vartheta < 70 \text{ °C}$	electrostatic charging	■	■	■
	abrasive			■
Product temperature $\vartheta > 70 \text{ °C}$	electrostatic charging			■
	abrasive			■
Illustration				

General installation instructions

Freefall metal detection systems are suitable as standard for product temperatures up to +70 °C and ambient temperatures up to +55 °C. The air cooling option may be required with higher temperatures. We are happy to help you integrate the system into your process. Our Engineering Support team will create a custom frame for installation in your production line if required. Alternatively, you can select one of the versions listed here with larger pipe cross-sections or without a separator.

- The dimensions listed in the tables apply to the 'drop heights above flange' specified in the tables, when the product has a start speed of 0 metres per second (0 m/sec)
- The following tolerances may emerge through the production process with the diameters and wall thicknesses for the ceramic freefall pipes listed in the tables

NW	80	100	150	200	250	300
Di ceramic	80	100	150	200	250	300
+/- tolerance in mm	4.5	5.5	7	9	10	11

Vistus® complete system with separator SW

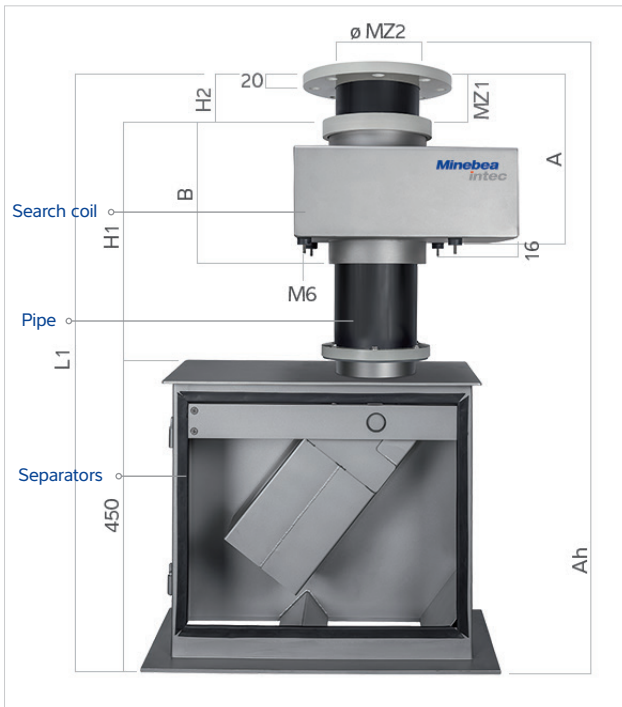

Legend	
NW	Nominal width – TCU in mm
MZ1	Length of metal-free zone
MZ2	Diameter of metal-free zone
L1	Freefall pipe with separator length in mm
Ah	Maximum drop height
A	Distance from flange F1 to rubber-bonded metal elements in mm
B	Wide search coil passage in feed direction in mm
H2	Distance from flange F1 to search coil inlet in mm

Only suitable for powdered material, as dust in the separator channel cannot be prevented. Additional dust barriers inside the separator can cause a dust blockage.

Standard version for Vistus® with separator SW

Vistus® R	5.9	8.4	12	17.2	21.6
Vistus®-TCU-SW	4	5	10	15	19
MZ1	47	67	100	140	165
MZ2 Ø	50	70.5	132.5	187.5	232.5
Ah	1,500	1,500	1,500	1,100	1,100
B	220	230	240	250	260
H1	250	260	270	276	336
H2	47	67	96	140	114
L1	730	760	820	870	900

Vistus® complete system without separator

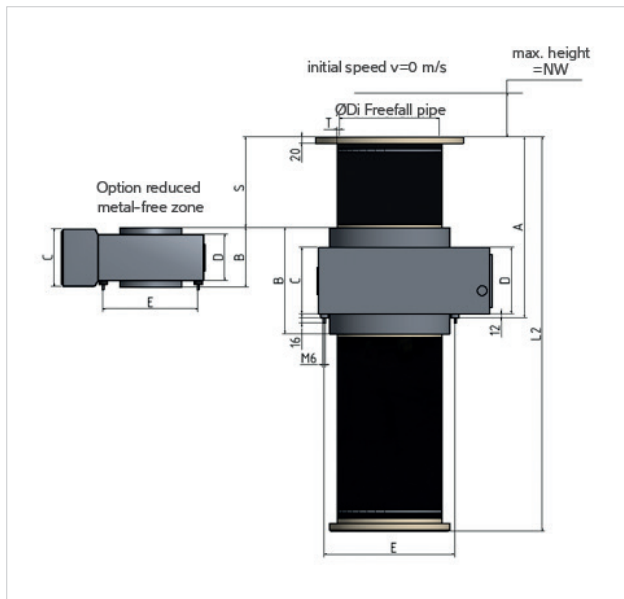

Coil and frefall pipe version

Metal detector opening	8.4	12	17.2	21.6	26.9	34.1
NW	80	100	150	200	250	300
Di PP	55.8	96.8	152.2	190.2	237.8	299.6
Di ESD	55.8	97.4	141.8	177.2	221.6	279.2
Di ceramic	--	80	100	150	200	250
T PP	3.6	6.6	3.9	4.9	6.1	7.7
T ESD	3.6	6.3	9.1	11.4	14.2	17.9
T ceramic	--	10	10	10	10	10
L2	364	432	525	606	740	866
A	274	308	355	395	482	545
B	230	240	250	260	310	320
C	160	160	160	160	200	200
D	160	160	160	160	200	200
D1	125	180	240	295	350	400
D2	18	18	22	22	22	22
D3	165	220	285	340	395	445
E	160	160	256	256	395	395
S	67	96	138	173	215	273

Coil and frefall pipe version with shielding and/or air cooling

Metal detector opening	12	17.2	21.6	26.9	34.1	34.1
NW	80	100	150	200	250	300
Di PP	55.8	96.8	152.2	190.2	237.8	299.6
Di ceramic	80	100	150	200	250	300
T PP	3.6	6.6	3.9	4.9	6.1	7.7
T ceramic	10	10	10	10	10	10
L2	432	525	606	740	866	866
A	308	355	395	482	545	545
B	240	250	260	310	320	320
C	160	160	160	160	200	200
D	160	160	160	160	200	200
D1	125	180	240	295	350	400
D2	18	18	22	22	22	22
D3	165	220	285	340	395	445
E	160	160	256	256	395	395
S	96	138	173	215	273	273

Coil and frefall pipe version with reduced metal-free zone

Metal detector opening	8.4	12	17.2	21.6	26.9	34.1
NW	80	100	150	200	250	300
Di PP	55.8	96.8	152.2	190.2	237.8	299.6
Di ESD	55.8	97.4	141.8	177.2	221.6	279.2
Di ceramic	--	80	100	150	200	250
T PP	3.6	6.6	3.9	4.9	6.1	7.7
T ESD	3.6	6.3	9.1	11.4	14.2	17.9
T ceramic	--	10	10	10	10	10
L2	196	279	400	501	624	791
A	144	199	281	349	432	544
B	88	125	180	225	280	355
C	68	96	138	173	215	273
D	173	173	173	173	215	215
D1	125	180	240	295	350	400
D2	18	18	22	22	22	22
D3	165	220	285	340	395	445
E	160	160	256	256	395	395
S	54	77	110	138	172	218

Air pressure monitoring and compressed air conditioning



When you purchase a freefall system Vistus® with separator, 5 L/2 L air cells, air pressure monitoring and a pressure relief valve are all included (5 L from nominal width 250 upwards, if not 2 L). The pressure relief valve comes with a sound absorber. The components, made by the market leader, are high-quality and long-lasting.

Hole size, 2 L air cell

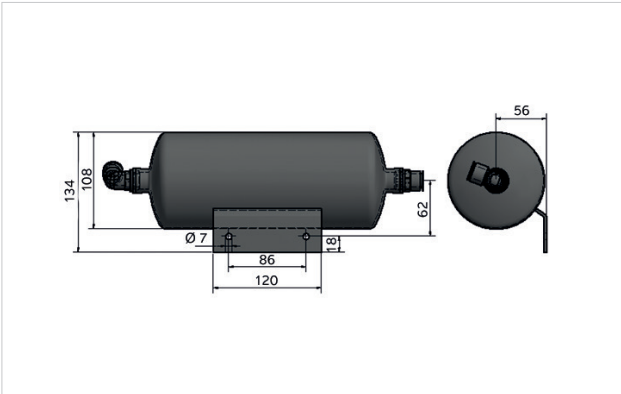

Standard maintenance unit

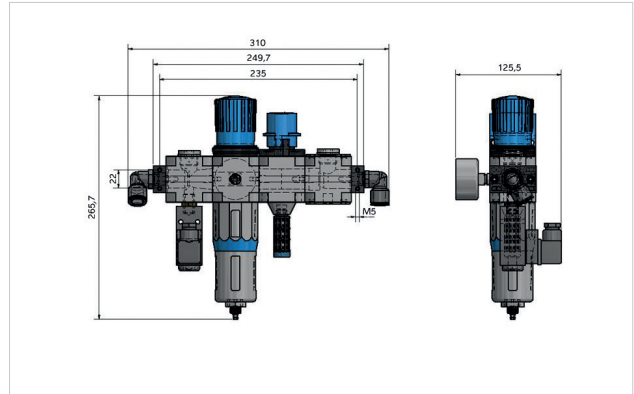

An optional hygienic protective housing is available for the compressed air conditioning.

Scale drawing of connection flange and TCU-SW connection

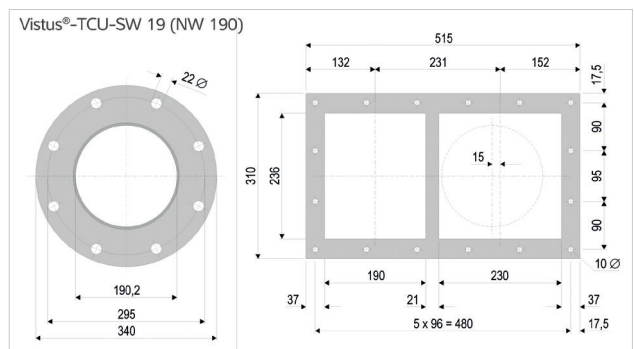
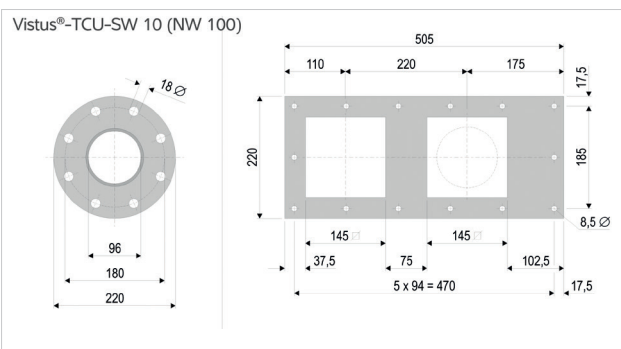
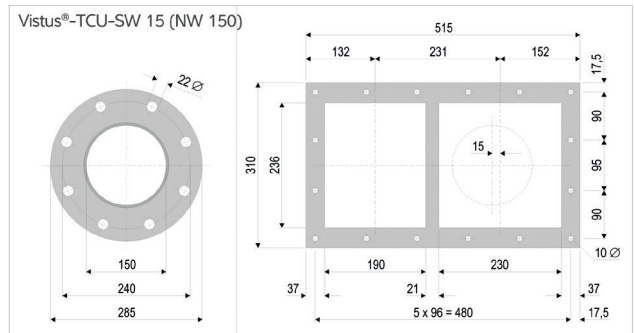
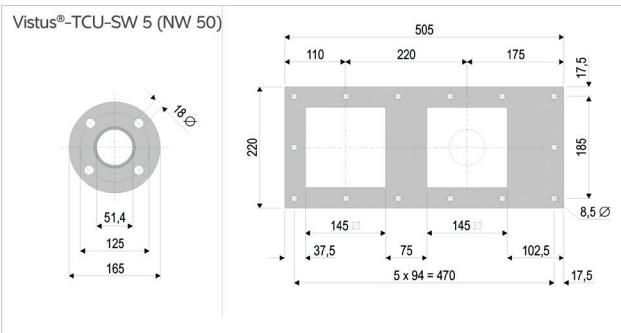

Outlet spouts with flanges (F1 according to DIN 2501 PN10)

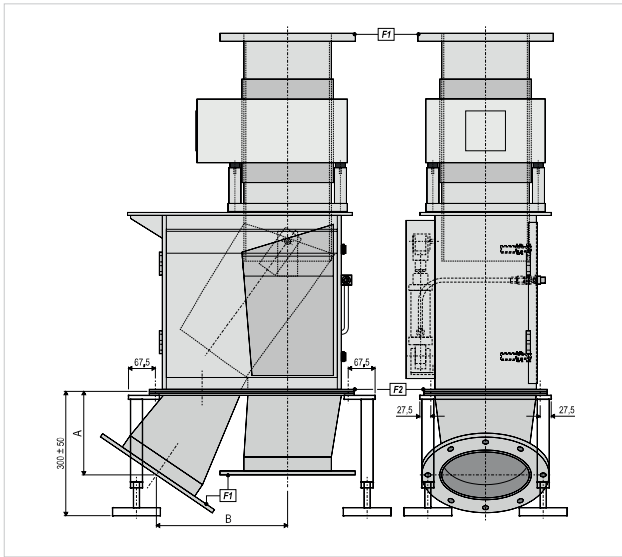

Vistus®-TCU-SW	5	10	15	19
A	179	179	179	210
B	284	284	280	328

Stand is available at the request of the customer for a surcharge.

Technical data for Vistus® TCU with separator SW

Supply pressure	max. 3 bar overpressure (4 bar absolute)	
Operating medium	Compressed air as per ISO 8573-1:2010 [7:4:4]	
Air consumption	Approx. 1 litre per separation at 3 bar	
Compressed air connection solenoid valve	G 1/4" internal thread for tube connection 6 mm (insert symbol for diameter)	
Compressed air tank	G 1/2" with connection for plastic tube 14 mm	
Pressure relief valve	Provided free of charge to protect your system	
Recommended on-site compressed air quality	Particulate matter class 4 Water class 2 Oil class 2	(Quality classes as per PNEUROP recommendation 6611)
Drop height	Max. distance to inlet flange for initial speed $v = 0$ m/s depending on the respective nominal width (NW) in mm (greater drop heights require larger installation dimensions)	
Solenoid valve	5/2-way valve monostable	
- Supply voltage	Choice of 230 V _{AC} or 115 V _{AC} 50/60 Hz, or 24 V _{DC} standard or 48 V _{DC} (please specify any deviations from the standard (24 V DC) upon order).	
- Activation	Via 'Metal' relay on evaluation electronics	
Protection class	IP54	
User interface	145 mm (5.7") touchscreen Password-protected, user-specific access to dialogues that are organised and adapted by functional areas Automatic teach-in function	
Relay outputs	Total of 4 relays ---> relays 1, 3 and 4 freely programmable Relay 2 'Error': fixed assignment	
Relative air humidity	operation: < 58 % at +55 °C / Storage: < 30 % at +70 °C, 0 % to 90 % condensation-free	
Ambient temperature	in operation: -10 °C to +55 °C	
Product temperature	-30 °C to +55 °C, but product temperatures of up to +150 °C are possible if needed, if air cooling is connected, subject to the product characteristics	

Options

Various additional options

- End position monitoring
- Signal lights & signal horn
- Fill level monitoring
- Fingerprint sensor



Scope of delivery: 4 x test balls, or test rods; other test part options are available

Interfaces

- RS 232, RS 422
- USB printing
- TCP-IP XML server/client
- Remote control
- Profibus
- SPC@Enterprise

The technical data given serves as a product description only and should not be understood as guaranteed properties in the legal sense.

Specifications subject to change without notice.

Rev. 10.2017

Minebea Intec Aachen GmbH & Co. KG
Am Gut Wolf 11
52070 Aachen, Germany
Phone +49.241.1827.0
sales.ac@minebea-intec.com
www.minebea-intec.com