

## Specifications

Integrated Mold Sensing System  
Temperature Relay Box

MIS-304-T

Spec. No. EN353304T-A

1/4

### 1. General

This unit is used when wiring the temperature sensor embedded in the mold to the Integrated Mold Sensing System: Amplifier MIS-202-\*\*. A dedicated cable FA409-549-\*M is required to connect to the Amplifier MIS-202-\*\*.

#### 1-1. Systematic chart

Example of MIS-202-PT (Pressure: 4CH, Temperature: 4CH)

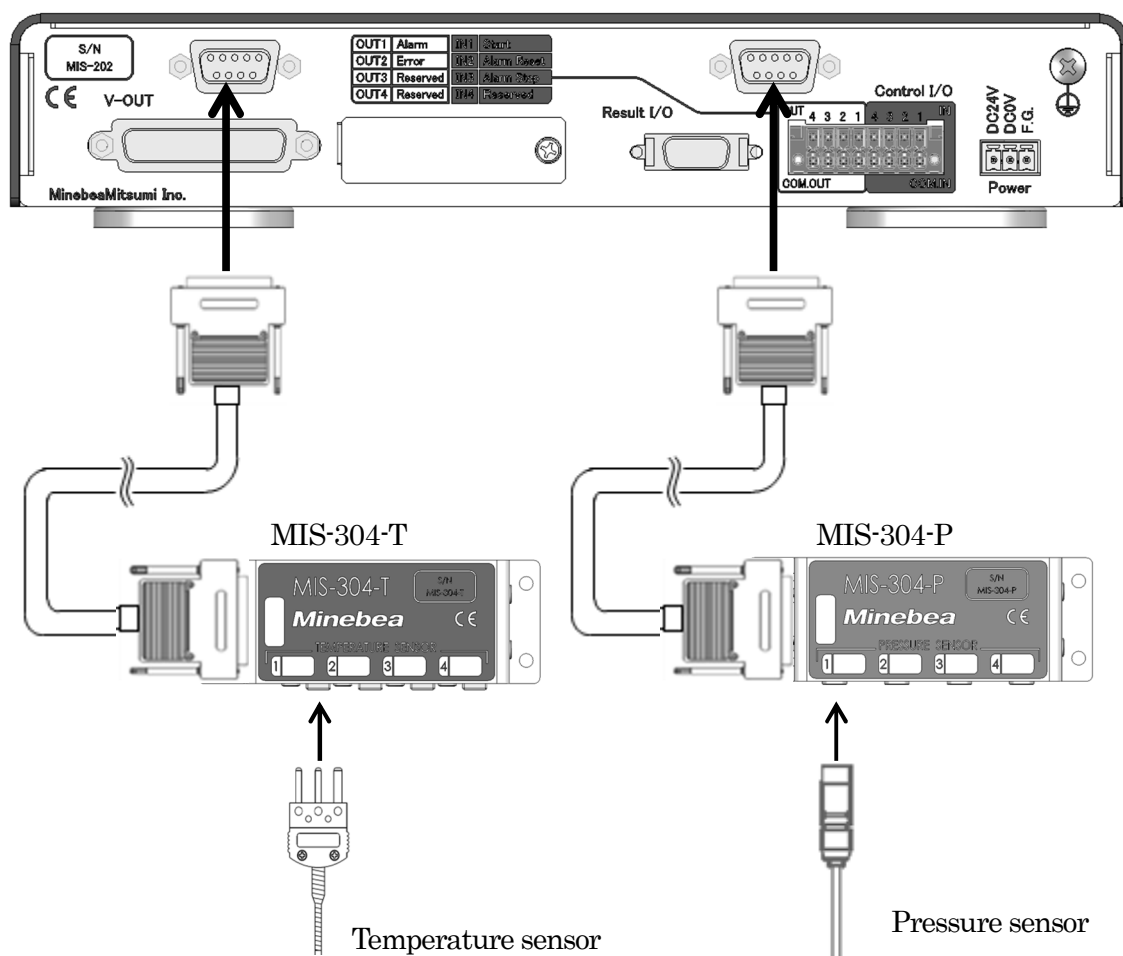

## Specifications

MIS-304-T

Spec. No. EN353304T-A

2/4

### 2. General Specifications

- Operating temperature range 0 °C to 70 °C  
0 °C to 100 °C (When magnet is not used.)
- Operating humidity range 85 %RH or less (Non Condensing)
- Stored temperature range - 10 °C to 70 °C  
- 10 °C to 100 °C (When magnet is not used.)
- Vibration resistance 10 Hz to 55 Hz double amplitude 1.5 mm  
2 hours for each direction of X, Y or Z.
- Outline dimensions (W×H×D) 111.6 mm×40 mm×40.4 mm (Excludes protruding parts.)
- Weight Approx. 220 g (Including magnet.)
- Material of case SUS430
- Applicable transducer Type K thermocouple MMTK-01
- Applicable amplifier MIS-202-PT

### 3. Accessories /Accompanying items

- Instruction manual 1 pad

### 4. Temperature Relay Cable (Options)

- Model FA409-549-2M (Cable length 2 m)  
FA409-549-5M (Cable length 5 m)  
FA409-549-10M (Cable length 10 m)
- Operating temperature range 0 °C to 100 °C
- Operating humidity range 85 %RH or less (Non Condensing)
- Stored temperature range 0 °C to 50 °C
- Cable outer diameter Approx. 8.8 mm
- Minimum bending radius Fixed part: 70 mm; Movable part: 100 mm

## Specifications

MIS-304-T

Spec. No. EN353304T-A

3/4

### 5. Outline dimensions

Relay Box MIS-304-T

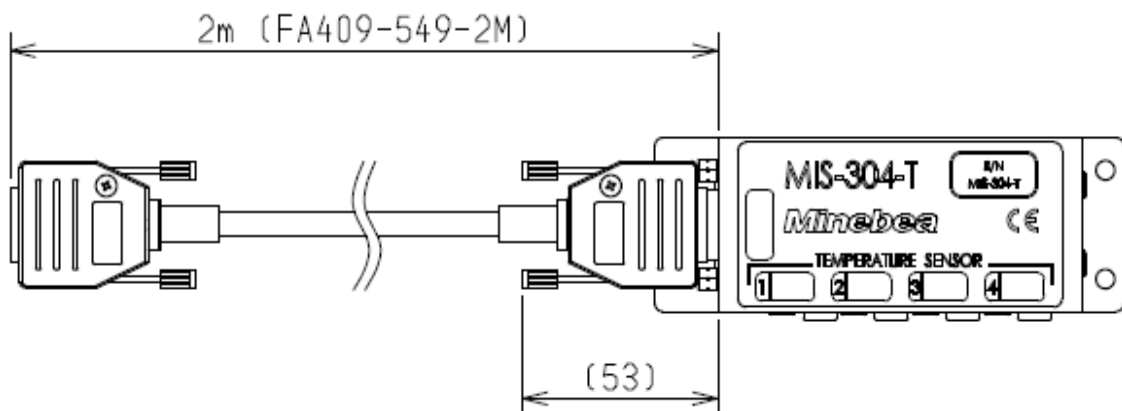
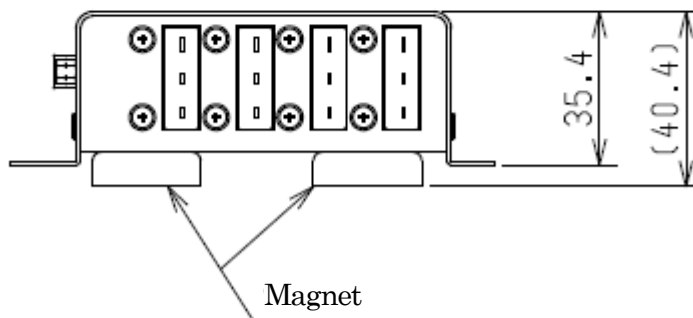
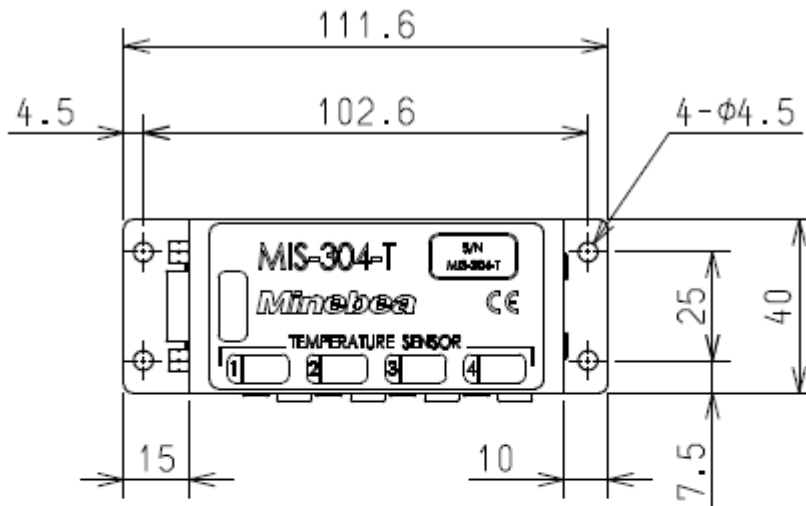

Unit:mm

Note) It is possible to fix with screws by the mounting holes on both sides.  
In that case, remove the magnet.

## Specifications

MIS-304-T

Spec. No. EN353304T-A

4/4

### 6. Applicable standards

- This unit conforms to the following standards.  
EN61326-1: 2013  
[Electrical equipment for measurement, control and laboratory use. EMC requirements. General requirements]

RoHS compliant

To meet the above-mentioned standards, the usage conditions of the entire system including this unit are specified as follows:

#### 6-1. Power source

- Be sure to use "CE mark compliant product" as DC 24 V power supply for the Amplifier MIS-202-\*\*.

#### 6-2. Cable

- Use shielded cables for all cables.
- Use the supplied USB cables.
- Use the dedicated cables sold separately for CH extension cable, judgement output cable and V-OUT cable.

#### 6-3. Shield processing

- Connect the shield wire of control I/O cable to the protective ground terminal on the rear panel.
- Connect the shield of the power cable to F.G. terminal of the connector.
- Ground the opposition side shield of all cables. (Ground at both ends)

#### 6-4. Ground

- Make a single ground for the Amplifier MIS-202-\*\* with the protective ground terminal on the rear panel.
- Ground the slave unit as well in the case of CH extension.

Note)

The specifications or appearance described in this document may be changed for improvement without a prior notice.