

Specifications

Molding Pressure Conversion Module
Amplifier

MPC-203-25

Spec. No. EN382203-25A

1/14

1. General

This is a digital conversion module of (4) channels input that measures the resin pressure in the metal mold of the injection molding machine. The pressure is watched on the condition set beforehand, and the result is output as an alarm signal. Moreover, the pressure waveform converted into the analog voltage can be transmitted to the molding machine. In addition, the real-time pressure waveform display, save, read-out, analysis and various set can be provided by using the application software for the personal computer.

1-1. Systematic chart

Configuration example

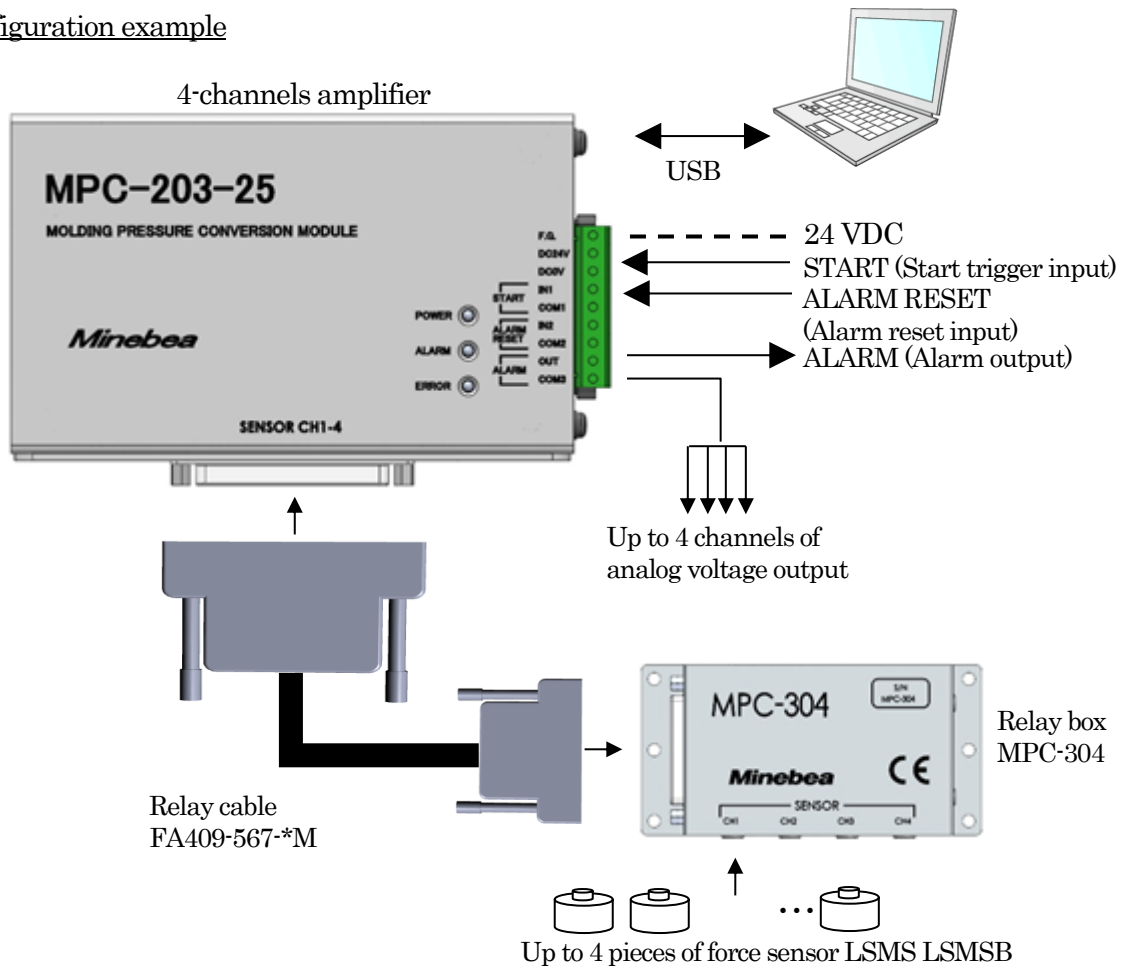

*This unit can be also used by connecting the relay box MRB-304-BI or MRB-304-CV.

1-2. Outline of system function

- Pressure measurement, Alarm judgement result output, Analog voltage output
- Real-time pressure waveform display, analysis, statistics, save and print by a special application.
- Various setting and writing/reading out of sensor sensitivity by the special application.

Specifications

MPC-203-25

Spec. No. EN382203-25A

2/14

2. Specifications

2-1. Specifications for analog input

- Bridge power supply DC5V±0.25 V within 20 mA per 1 channel
- Applicable transducer Strain gage based transducer (350 Ω, 1 unit/channel)
LSMS-S06 series, LSMSB series.
* The model of 2 000.0 N or more (200K, 500K, 1T and 3T) corresponds since ROM Ver. 1.200.
- Numbers of input points Up to 4 channels
- Input range -0.1 mV/V ~ 0.8 mV/V
- Zero adjustment range Zero set function can be adjusted in the range from -0.1 mV/V to 0.7 mV/V.
- Accuracy ±2.0 %F.S.
- Sampling interval 10 ms for each channel
(Changeable to 0.5 ms, 1 ms, 2 ms, 5 ms, 20 ms or 50 ms.)
* Limited to 10 ms, 20 ms, 50 ms at the long time measurement
- A/D internal resolution 16 bit
- Analog filter Approx. 500 Hz

2-2. Specification for analog output

- Number of output points Up to 4 channels
- Output voltage 0 VDC ~ 10 VDC
- Load resistance 5 kΩ or more
- Resolution 1/12 000 or more
- Output frequency Synchronized with A/D sampling rate.
- Over range Approx. 11 V at 110 % or more of the rated pressure.
Approx. -1 V at -10% or less of the rated pressure.

2-3. Specification for digital

- Measuring range 0 MPa ~ 999.99 MPa (Conversion value from pressure receiving area)
- Unit MPa
- Status LED POWER, ALARM, ERROR

Specifications

MPC-203-25

Spec. No. EN382203-25A

3/14

2-4. Specifications for setting

- EEPROM Measurement condition set, Alarm function set
- RAM Zero set data, Measuring mode (Overlay / Continuous)

2-5. Measurement condition set

- Sensor set Rated capacity, rated output and pressure receiving area.
- Measuring time set Up to 120 s, Up to 600 s at the long time measurement
* The long time measurement corresponds since ROM Ver. 1.220.
- Start trigger input set Selectable from rising up and falling down.
Effective only once at the pulse width of 50 ms or more.
- Start trigger input delay time set
0.0 s ~ 25.0 s
- Peak over eject (POE) detection time set
Start time: 0.00 s ~ 600.00 s,
Finish time: 0.00 s ~ 600.00 s
*121 seconds or more is available only in the long time measurement

2-6. Alarm function set

- Effective/Invalid set of channel
Selectable from effective and invalid of alarm watch of each channel.
- Watch frame condition set Selectable from effective and invalid in system 1 ~ 3 of each channel.
Area watch, Peak watch, Watch at (t) second later and Watch at the peak arrival time.
Pressure : Lower limit 0.00 ~ 200.00 MPa
Upper limit 0.00 ~ 200.00 MPa
Time : Start 0.00 ~ 600.00 s
Finish 0.00 ~ 600.00 s
*121 seconds or more is available only in the long time measurement
* The area watch can be set in system 1 and system 3.
* [Watch at (t) second later] and [Watch at the peak arrival time] cannot be set in two or more systems.
- Integral value condition set
Selectable from effective and invalid of each channel.
Integral value watch and peak arrival integral value watch
Integral value: Lower limit 0.00 = 120 000.00 MPa·s,
Upper limit 0.00 = 120 000.00 MPa·s,
- Alarm output set Selectable from rising up and falling down.
- Alarm reset input time set Selectable from effective and invalid of time control.
Time setting when effective: 1.0 s ~ 25.0 s
- Alarm reset input set Selectable from effective and invalid of alarm reset input.
Signal setting when effective: Selectable from rising up and falling down.

Specifications

MPC-203-25

Spec. No. EN382203-25A

4/14

2-7. External control function

- External control input signal
 - Start trigger input Start measurement
 - Alarm reset input Reset the alarm output condition
- *Above is level input, and effective once at the pulse width of 50 ms or more.
- Equivalent circuit of external control input

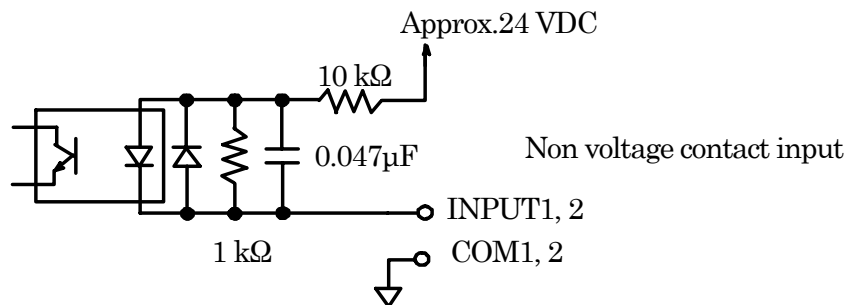

* The internal circuit is insulated by photocoupler.

- External control output signal
 - Alarm output Output the judgement result on various alarm condition.
- Equivalent circuit of external control output

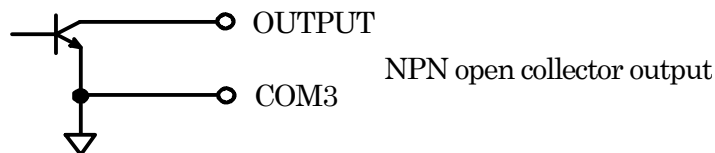

Rated open collector $V_{CE} = 35 \text{ VDC max.}, I_c = 100 \text{ mADC max.}$

* The internal circuit is insulated by photocoupler.

2-8. USB interface

- Specification Conformed to USB Specification 2.0/1.1
- Output connector Mini-USB B-type connector (Female)
- * Installation of the attached special driver software for PC is required.

Specifications

MPC-203-25

Spec. No. EN382203-25A

5/14

2-9. Connector configuration

- Power supply and external control I/O

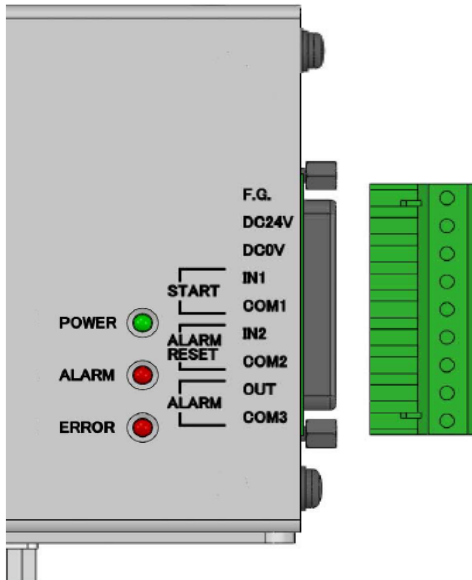

Signal name	Contents
F.G.	Frame ground
24 VDC	Power supply 24 VDC
0 VDC	Power supply 0 VDC
IN1	Start trigger input
COM1	Signal ground
IN2	Alarm reset input
COM2	Signal ground
OUT	Alarm output
COM3	Signal ground

*Attached applicable plug : XW4B-09C1-H1 (made by OMRON.)

*COM1 and COM2 are common internally, and COM3 is separated.

- Analog voltage output

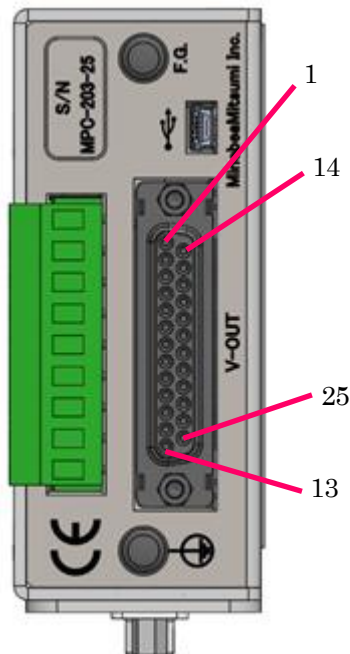

Pin No.	Signal name	Pin No.	Signal name
1	N.C.		
2	N.C.	14	N.C.
3	N.C.	15	N.C.
4	N.C.	16	N.C.
5	N.C.	17	N.C.
6	N.C.	18	N.C.
7	N.C.	19	N.C.
8	N.C.	20	N.C.
9	N.C.	21	N.C.
10	+OUT4	22	-OUT4
11	+OUT3	23	-OUT3
12	+OUT2	24	-OUT2
13	+OUT1	25	-OUT1

* Applicable plug: Main DB-25PF-N, Cover DB-C8-J10-F4-1R (made by JAE.)

* The engagement fixation stand screw is inch screw.

Specifications

MPC-203-25

Spec. No. EN382203-25A

6/14

2-10. Connection of sensor and relay box

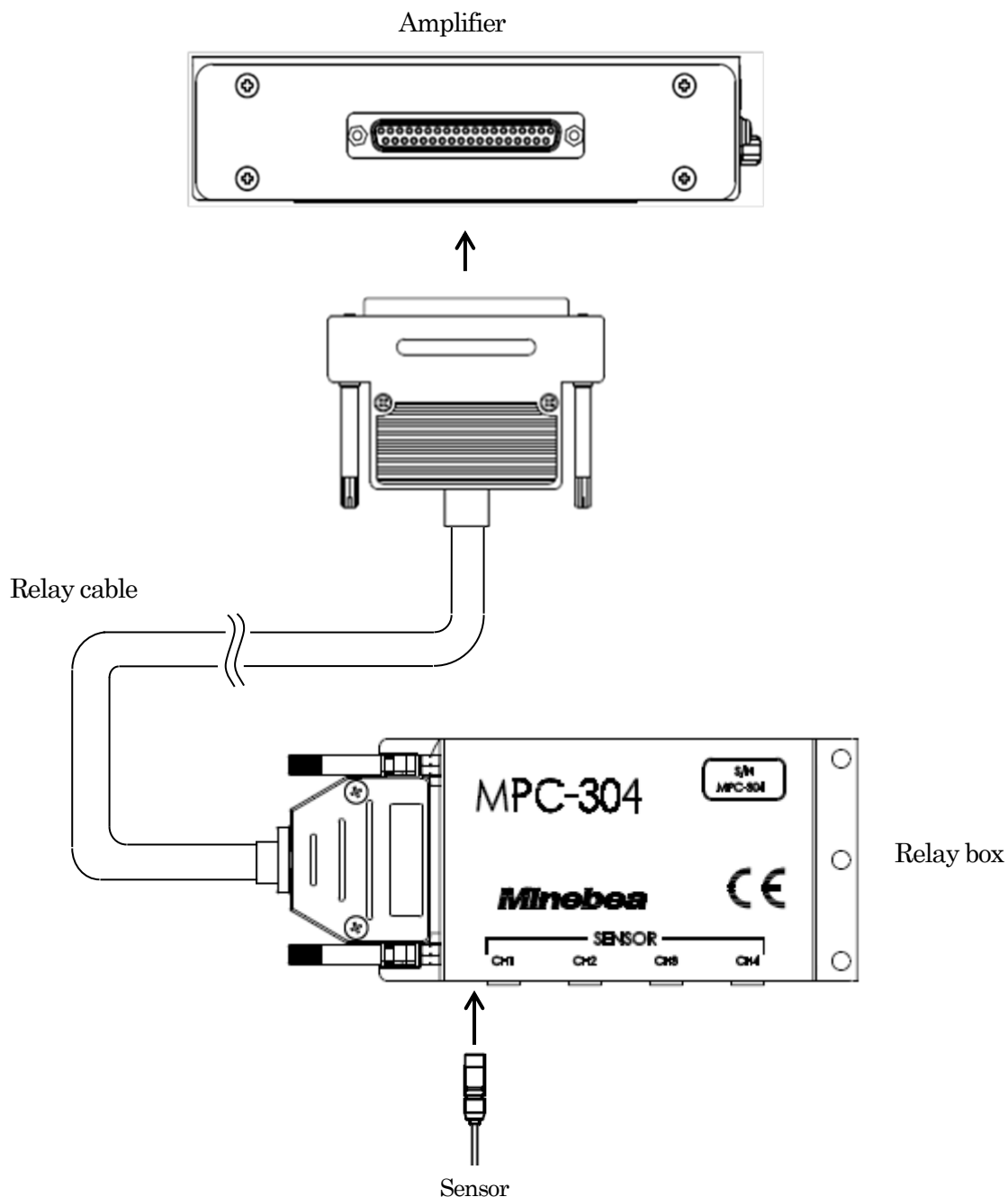

- To connect the relay box MPC-304 or MRB-304-BI or MRB-304-CV, use the relay cable FA409-567-*M.
- Insert the plug of sensor into relay box.

Specifications

MPC-203-25

Spec. No. EN382203-25A

7/14

2-11. Various function (Special application software: MIP-D-02)

2-11-1. System requirement

Personal computer	PC/AT compatible unit
	OS: Windows 10, 11
	CPU: 2 GHz or more
	RAM: Windows 10: 4.0 GB or more Windows 11: 8.0 GB or more
	HDD: 1 GB or more of empty capacity in hard disk is required.
	USB port: 1 port is required.
	CD-ROM drive: Required.
	Mouse or substitute: Required.
	Keyboard: Required.
Monitor	Resolution 1 280 x 768 or more
Color printer	Required in printing

* This software doesn't guarantee operation with all personal computers.

* OS versions that are no longer supported by the OS manufacturer are not covered by the guarantee.

2-11-2. Waveform display function

- Real-time waveform display
- Overlay waveform display
- Trend display (Peak pressure, Integral value or Protruding pressure)
- Display channel selection
- Waveform expansion
- Alarm watch frame display
- Graph scale automatic adjustment
(Real-time waveform display, Overlay waveform display, Trend display)

2-11-3. Measurement processing function

- Sequential waveforms (This waveform draws continuously regardless of the measurement time.)
Zero set: When the acquisition of sequential waveforms begins. , Manual.
- Overlay waveform (This draws in the waveform of each shot repeatedly.)
Zero set: This draws by the start trigger input.
- Reference waveform registration
- Peak pressure, Integral value and Current pressure display (Select two from three)
- Counter of shot number (Total shot number, OK shot number and NG shot number)

2-11-4. Measurement condition setting function

- Set of channel name
 - Set of sensor
 - Set of sampling interval
 - Set of measurement time
 - Set of start trigger input
 - Set of start trigger input delay time
 - Set of start trigger input interrupt (since ROM Ver. 1.014)
 - Set of pressure detection range of peak over eject.
 - Set of overlay display frequency
 - Set of analog voltage output (Selectable from effective, invalid or scaling)
- * During the measurement, the above mentioned condition setting cannot be changed. Only inspection is possible.

Specifications

MPC-203-25

Spec. No. EN382203-25A

8/14

2-11-5. Data storing function

- The numerical data saving
(Save the same CSV type file for peak pressure, integral value, peak over eject pressure, alarm judgement result, etc., in every date.)
 - Save the overlay waveform data.
(Save the sampling data as the CSV type file in every shot, or NG shot and the one before and after.)
 - Save the alarm history (Save the numeric data of the waveform where the alarm is generated.)
- * This saving function of numeric data, waveform data and alarm history are changeable between effective and invalid.
- Save the screen copy of condition setting.

2-11-6. ALARM function

- Image display
- Effective or invalid of alarm judgement. (by each channel)
- Alarm reset input condition set
- Alarm output timing set (since ROM Ver. 1.014)
- Alarm output condition set (Time and external input signal)

2-11-7. Alarm judgement function

- Area watching frame judgement (Pressure value: Upper limit and lower limit, Time: Start and finish)
- Peak watching fram judgement (Pressure value: Upper limit and lower limit, Time: Start and finish)
- Watch at [t] second later (Pressure value: Upper limit and lower limit, Time: [t] second later)
- Watch of arrival time to peak (Time: Start and Finish)
- Watch of integral value (Integral value: Upper limit and lower limit)
- Watch of peak arrival integral value (Integral value: Upper limit and lower limit)

2-11-8. Data Processing function

- Reading out waveform data
- Calculation of pressure value of specified time
- Calculation of integral value in the specified time range.
- Drawing of horizon in specified pressure value

2-11-9. Check function

- ROM version check
- Monitoring function (Display the output value [mV/V] from sensor.)
- External control I/O operational check
- Analog output voltage check
- ERROR LED confirmation (since ROM Ver. 1.014)

2-11-10. Other function

- Statistical process (The average value, the maximum value, the minimum value and the standard deviation of the measurement of each channel are calculated.)
- Screen printing capability
- Password function (Prohibit changing of the setting for condition setting screen and stored place of data.)
- Threshold value setting of drive free space (since ROM Ver. 1.200).

Specifications

MPC-203-25

Spec. No. EN382203-25A

9/14

3. General Specification

- Operating temperature/humidity range
 - Temperature -10 °C ~ 50 °C
 - Humidity 85 %RH or less (Non Condensing)
- Stored temperature range -20 °C ~ 60 °C
- Vibration resistance 10 ~ 55 Hz double amplitude 1.5 mm
2 hours for each direction of X, Y or Z.
- Power supply
 - Power supply voltage 24 VDC (Available variable range 20.4 VDC ~ 27.6 VDC)
 - Power consumption Approx. 6 W (at 24 VDC)
- Outline dimensions (W)160 mm x (H)98 mm x (D)40 mm (Excludes protruding parts.)
- Weight Approx. 800 g

4. Accessories

- USB cable 2.0 m 1 piece
 - Ferrite core 1 piece (to be attached to USB cable.)
 - Plug for power supply and external control I/O 1 piece (XW4B-09C1-H1)
 - CD-ROM 1 piece
 - Instruction manual 1 pad
- *Special application (MIP-D-02) and the driver software are supplied to CD-ROM.

Specifications

MPC-203-25

Spec. No. EN382203-25A

10/14

5. Options

5-1. Relay box

5-1-1. MPC-304

- Model MPC-304
- Operating temperature/humidity range

Temperature	0 °C ~ 70 °C
	(When magnet is not used. 0 °C ~ 100 °C)
Humidity	85 %RH or less (Non Condensing)
- Stored temperature range -10 °C ~ 70 °C (When magnet is not used. -10 °C ~ 100 °C)
- Vibration resistance 10 ~ 55 Hz double amplitude 1.5 mm
2 hours for each direction of X, Y or Z.
- Outline dimensions (W) 120 mm x (H) 60 mm x (D) 35.4 mm (Excludes protruding parts.)
- Weight Approx. 300 g (Include magnet.)
- Material of case SUS430
- Applicable transducer LSMS-S06 series, LSMSB series

5-1-2. MPC-304-BI

- Model MPC-304-BI
- Operating temperature/humidity range

Temperature	0 °C ~ 100 °C
Humidity	85 %RH or less (Non Condensing)
- Stored temperature range -10 °C ~ 100 °C
- Vibration resistance 10 ~ 55 Hz double amplitude 1.5 mm
2 hours for each direction of X, Y or Z.
- Outline dimensions (W) 98 mm x (H) 14.8 mm x (D) 39.1 mm (Excludes protruding parts.)
- Weight Approx. 80 g
- Material of case SUS304
- Applicable transducer LSMS-S06 series, LSMSB series

5-1-3. MPC-304-CV

- Model MPC-304-CV
- Operating temperature/humidity range

Temperature	0 °C ~ 100 °C
Humidity	85 %RH or less (Non Condensing)
- Stored temperature range -10 °C ~ 100 °C
- Vibration resistance 10 ~ 55 Hz double amplitude 1.5 mm
2 hours for each direction of X, Y or Z.
- Outline dimensions (W) 121.6 mm x (H) 17.2 mm x (D) 70.9 mm (Excludes protruding parts.)
- Weight Approx. 210 g
- Material of case SUS304
- Applicable transducer LSMS-S06 series, LSMSB series

Specifications

MPC-203-25

Spec. No. EN382203-25A

11/14

5-2. Relay cable

5-2-1. FA409-567

- Model

FA409-567-2M	(Cable length 2m)
FA409-567-5M	(Cable length 5m)
FA409-567-10M	(Cable length 10m)
- Operating temperature/humidity range

Temperature	0 °C ~ 100 °C
	(Connector on amplifier side 0 °C~50 °C)
Humidity	85 %RH or less (Non Condensing)
- Stored temperature range

0 °C ~ 50 °C	
	(Because operation temperature range of the connector on amplifier side is up to 50°C.)
- Cable outer diameter Approx. 7.1mm
- Minimum bending radius 50mm

5-2-2. FA409-541

- Model

FA409-541-2M	(Cable length 2m)
FA409-541-5M	(Cable length 5m)
FA409-541-10M	(Cable length 10m)
- Operating temperature/humidity range

Temperature	0 °C ~ 100 °C
	(Connector on amplifier side 0 °C~50 °C)
Humidity	85 %RH or less (Non Condensing)
- Stored temperature range

0 °C ~ 50 °C	
	(Because operation temperature range of the connector on amplifier side is up to 50°C.)
- Cable outer diameter Approx. 8.3mm
- Minimum bending radius 50mm

Specifications

MPC-203-25

Spec. No. EN382203-25A

12/14

5-3. Analog voltage output cable

- Model FA409-476
- Cable length 2.5 m
- Operating temperature/humidity range
 - Temperature 0 °C ~ 50 °C
 - Humidity 85 %RH or less (Non Condensing)
- Stored temperature range 0 °C ~ 50 °C
- Cable outer diameter Approx. 9.0mm
- Minimum bending radius 54mm

5-4. External control I/O cable

- Model FA409-477
- Cable length 2.5 m
- Operating temperature/humidity range
 - Temperature 0 °C ~ 50 °C
 - Humidity 85 %RH or less (Non Condensing)
- Stored temperature range 0 °C ~ 50 °C
- Cable outer diameter Approx. 7.3mm
- Minimum bending radius 44mm

Specifications

MPC-203-25

Spec. No. EN382203-25A

14/14

7. Conformity standard

- This instrument has suited the following standard.
EN61326-1:2013
[Electrical equipment for measurement, control, and laboratory use - EMC requirements]
[Immunity test requirements for equipment intended for use in industrial locations]
EN50581:2012
[Technical documentation for the assessment of electrical and electronic products with respect to the restriction of hazardous substances] (RoHS Directive)

The using conditions to suit this instrument to the above are as follows,

7-1. Power supply

- The power supply of 24 VDC must use [CE applied product].

7-2. Cable

- Use the shielded cable other than the power cable.
- Mount the provided ferrite core to USB cable as shown in [5-2-4. USB connection] of the instruction manual of this instrument.

7-3. Shield processing

- Connect the shield cable of I/O with the protective ground terminal.
- Connect the shield cable of V-OUT with F.G. terminal.
- Ground the shield of the opposite side of the I/O cable and the V-OUT cable. (Both ends grounding)

7-4. Grounding

- The ground of this instrument shall apply the individual ground by using the protective ground terminal.

* Specifications and outline dimensions and so on which have printed may subject to change for the purpose of improvement without notice.