

●Guide Specifications

Model No. TGS-XXX (XXX:Diameter for Tie-bar)
 Diameter for Tie-bar Φ XXX \pm 0.5 mm

Material
 Tie-bar gage attachment : Aluminum
 Attachment belt : Stainless steel
 Others : Steel

●Accessories

Tie-bar gage attachment bolt 6 pcs
 It attaches, when it purchases together Tie-bar gage.

●Options

Tie-bar gage UX010 2 pcs
 Amplofire ①CSA-591 1 pcs
 ②CSD-592 1 pcs

●Composition

NO	Name	Q'ty
1	Tie-bar gage attachment	2
2	Attachment belt	1
3	Tie-bar gage attachment bolt	6

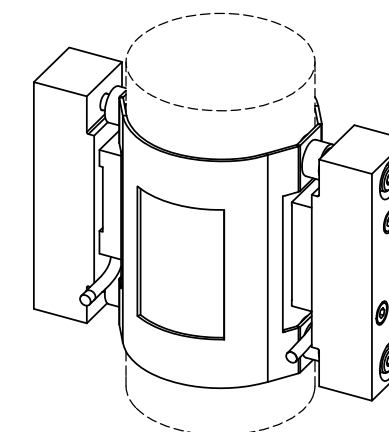

Image

			ミネベア株式会社 MINEBEA CO.,LTD. 計測機器事業部		単位 UNIT mm 尺度 SCALE FREE	材質 MATERIAL 表面粗サ SURF.ROUGH. 熱処理 HEAT TREAT. 表面処理 FINISH	作成日 DATE 2014/01/20 品名 DESCRIPTION Tie Bar Gage Guide for control 品番 PART NO.(MODEL NO.) TGS-XXX 図番 DRAWING NO. KX51898-2-ENG	葉番 SHEET 1 / 1 改訂 REV. 0
0	14/01/20	NEW			寸法公差 TOL 寸法 L 公差 L ≤ 4 ±0.1 4 < L ≤ 16 ±0.2 16 < L ≤ 63 ±0.3 63 < L ≤ 250 ±0.5 250 < L ≤ 1000 ±0.8 角度 DEG ±0.5			
符号 MARK	日付 DATE	変更事由 REASON	ECN NO.					