

Installation procedures for TGS-XXX

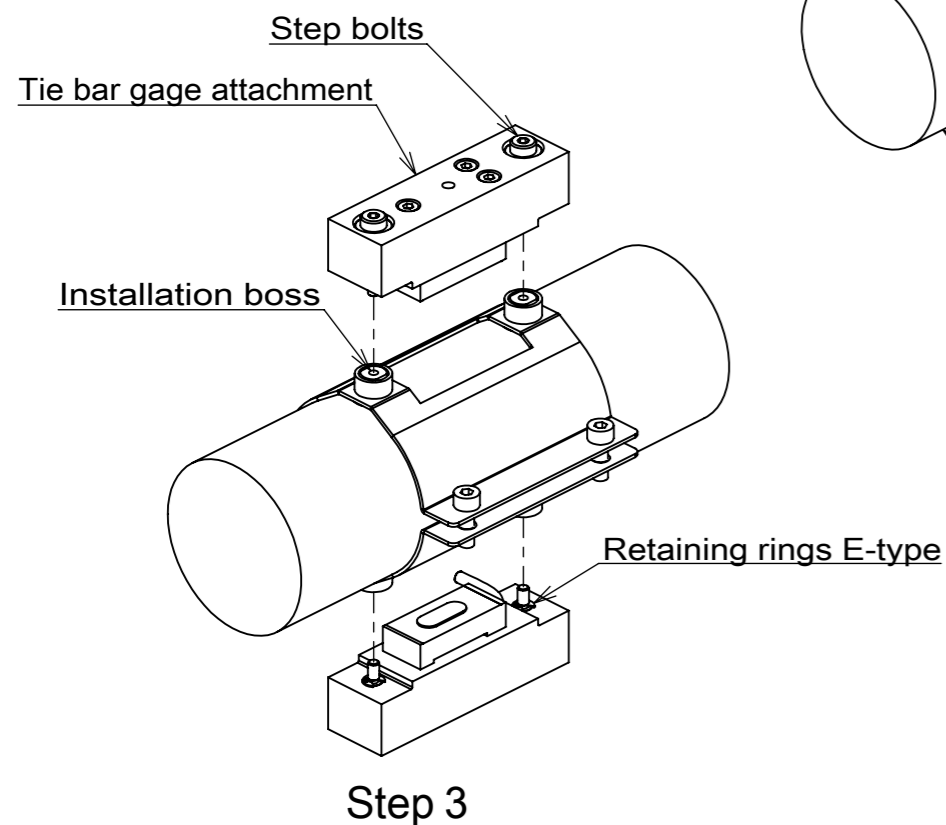
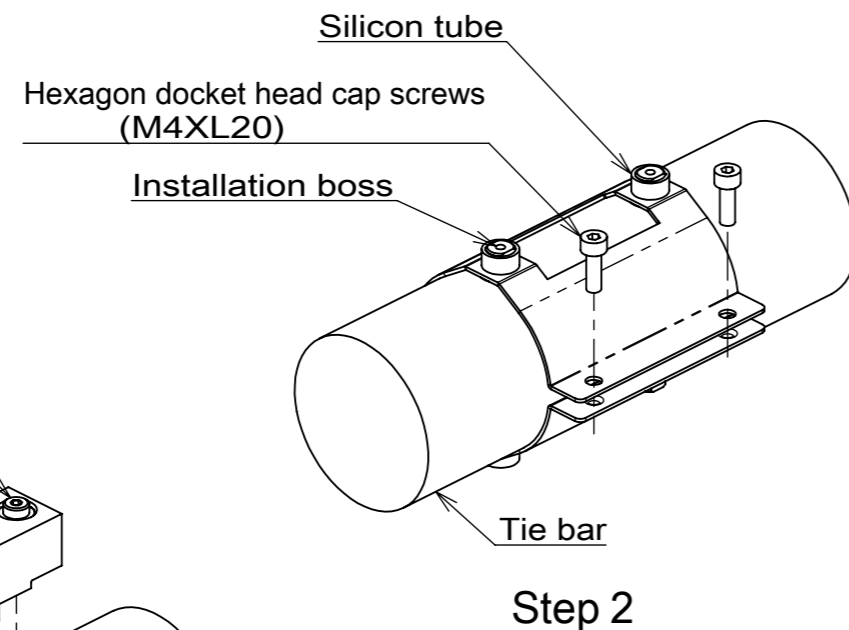
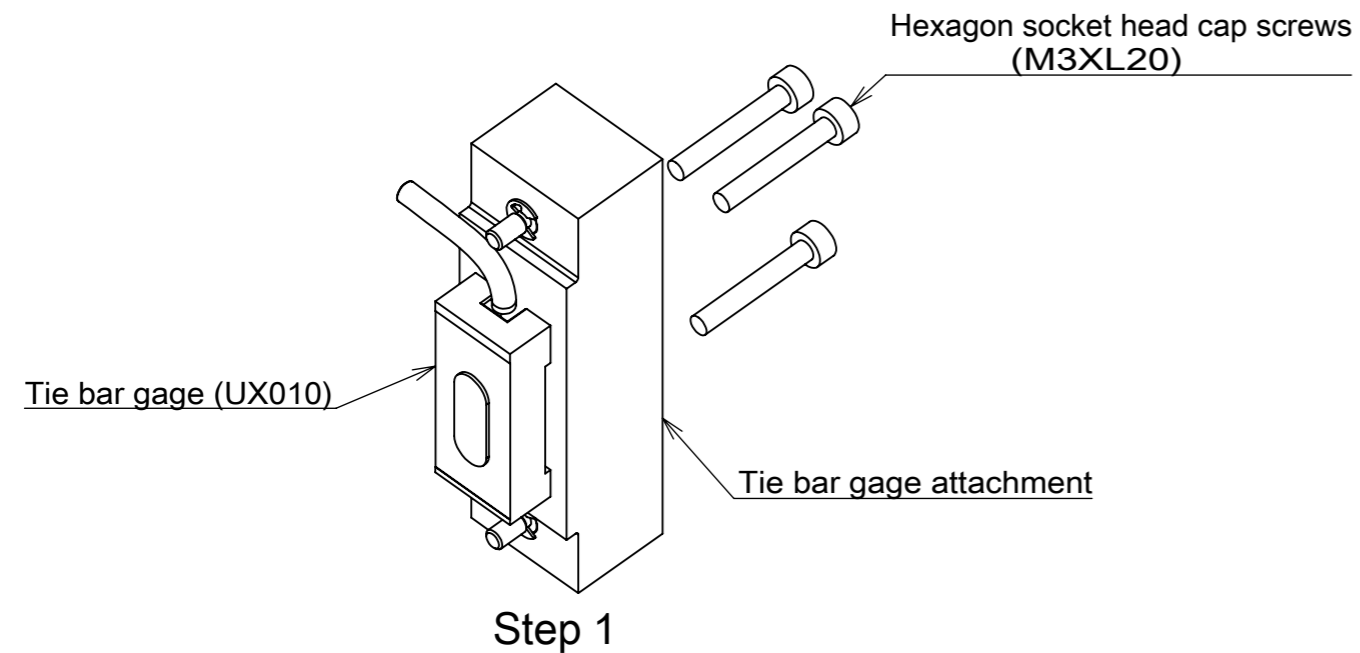

Installation procedures for Tie Bar Gage Guide for control

Step 1 : Installing Tie bar gage

- ① Install the Tie Bar Gage to the metal attachment of Tie Bar Gage
(When you purchasing a Tie Bar gage guide for control and a Tie Bar Gage at the same time, this step ① shall be not required, since they are shipped with the Tie Bar Gage installed condition together.)

Step 2 : Installation of installation belt

- ① Clean off oil and dirt on the surface where you want to install the Tie Bar Gage.
- ② Insert the Tie Bar in with the installation belt opened.
- ③ Pulling the bending section of installation belt together, tighten up the installation belt with the attached hexagon socket head cap screws (2 places).
In this case, take care not to tighten up one side only, but tighten up both of them one by one alternatively.

(recommended clamping torque : 1.5 N · m)

- ✗ The installation boss is held with a silicon tube not to drop down, but if it dropped down, insert it from the internal of belt and cover the silicon tube from outside to fix firmly.

Step 3 : Installation of Tie Bar Gage

- ① Install the installation board for Tie Bar Gage with step bolts.
In this case, take care not to tighten up one side only at a time, but tighten up 2 places one by one alternatively.
Tighten up the step bolt until the step bolt will not rotate, that is, until the time that the E type retaining ring at the step section of step bolt attaches to the installation boss.
(Recommended clamping torque : 0.63 N · m)
- ② Insert the Tie bar gage to the opposite side of Tie bar as in the same way.

⚠ Warning

- Install the Tie bar gage after check is made, such as dirt or foreign bodies aren't be to hurt the surface of the Tie Bar Gage.
- Don't move the installation band with the Tie bar Gage attached.
There may have the case that the Tie Bar Gage will be destroyed.
- Take care not to screw up the screw too strong, since there may have the case that the screw section will be destroyed.
- In the case of screwing the step bolt in, if you screw it in inclined direction, there may have the case of destruction in screw thread.
So take care of it fully, when you install.