



Transmitter for Tie-bar gages
CSA-593

Instruction Manual

MINEBEA Co., Ltd.
Measuring Components Business Unit

294-1511A

Forwards

Thank you very much for your purchasing Minebea's Transmitter CSA-593.

This manual for CSA-593 explains the procedures and check point in operation. We would like you to read through this instruction manual with much care for the best use of our product to avoid malfunctions.

Moreover, the end user should keep the manual at hand.

Marks and references described in this manual

In this instruction manual, the following marks are used to understand the matters that indicate 'Don't do this.', 'Caution' and 'For reference'.

Please be sure to read following descriptions for safety.



Warning

This sign forewarns the presence of hazards that could result in serious injury or fatality when incorrectly handled.

Be sure to read to prevent from malfunction.



Caution

This sign forewarns the presence of hazard that the user may result in serious injury.



This sign describes a attention and a limitation, etc., in the operation and the work

For safe operation

Be sure to read this manual before use.

1. Location of installation

Caution

Use the instrument under the following condition.

- Environmental temperature : -10 °C ~ 70 °C
- Environmental humidity : 80 %RH or less. (Non-condensing)

Caution

Do not install the instrument in following places. It may cause damage to the instrument.

- (1) Environment not to set up.
- Places exposed to direct sunlight and/or places in the high temperature.
 - Places in a highly humid area.
 - Places where the instrument is directly affected by vibrations or mechanical shocks.
 - Environments with full of dust or coarse particulates.
 - Environments containing of corrosive gas or salt.
 - Environments with raid change in temperature and/or humidity.
 - Near the devices which generate magnetism or electromagnetic waves.
 - Environments vulnerable to radioactivity or radioactivity rays.
 - Environments where chemical reaction may take place such as a laboratory.

(2) Installation



Caution

Please secure and set up the space between this instrument and the device

Each dimensions of the instrument and required dimensions for the environmental spaces are as follows:

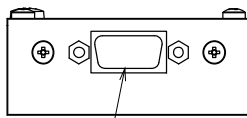
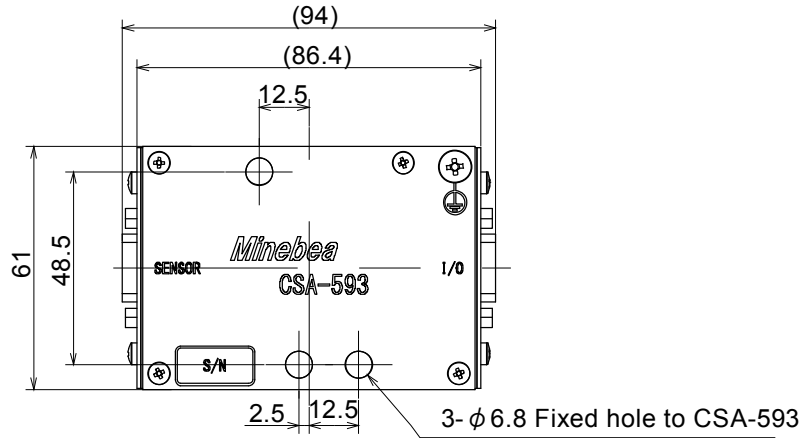

Input side from tie-bar gage
D-SUB 9PIN Female

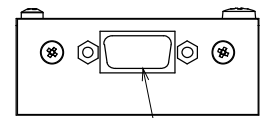
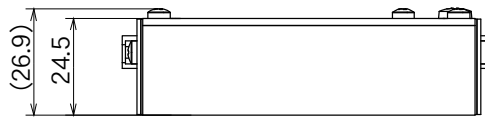

I/O signal side
D-SUB 9PIN Male

Unit: mm

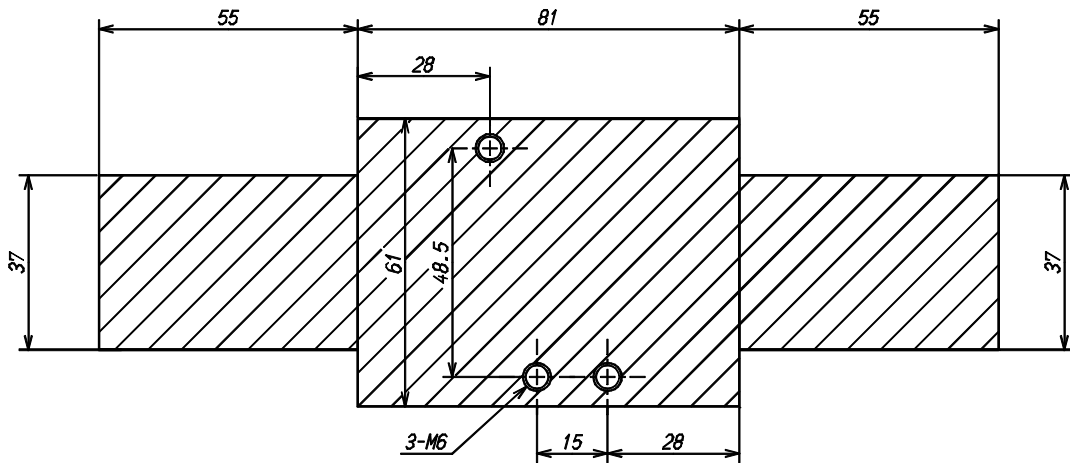

Unit : mm

(Shaded part: Occupation area when main body is connected with connector plug.)

2. Power supply

Warning

Be sure to check that power supply is OFF when installing each cable. If an operator works with power ON, operator may have an electric shock or the instrument may be destroyed.

Warning

Before supplying power, check the indication of power voltage/specifications to be identical with supplied power. If they are not identical, contact with Minebea. Without checking the above, operation may cause damage to the instrument or electric shock.

Caution

Be sure to ground a grounding wire.
If a grounding wire is not grounded, it may cause malfunction of the instrument or an electric shock to an operator.

3. Note for usage

Caution

When using the instrument, check that wires are connected properly. If neglected, correct measurement cannot be obtained and it may cause malfunction in the instrument or cause damage to peripheral devices or a critical accident.

Caution

Do not give the instrument such a shock as throwing something at it. It may cause damage or destroy electrical circuits and even have loose resistance to environment or operability.

Caution

Do not remove the cover of the case of the instrument, nor peel off the panel sheet nor take the instrument into pieces. If neglected, it may cause damage to the case and the panel sheet and even have the possibility of damage to resist to environments or operational performances.

Revision history

Date	Ref. No.	Contents (Reason of revised)
2012/08	DRW. NO.294-1511	First version Ver.1.000

Contents

FORWARDS	I
MARKS AND REFERENCES DESCRIBED IN THIS MANUAL	I
FOR SAFE OPERATION	II
1. LOCATION OF INSTALLATION	II
2. POWER SUPPLY.....	IV
3. NOTE FOR USAGE	IV
1. GENERAL	1
2. EACH NAME AND FUNCTION	1
3. WIRING	2
3-1. NOTE FOR CONNECTING WIRES	2
3-2. ALLOCATION OF CONNECTOR.....	2
3-3. WIRING	3
3-4. CONNECTION OF POWER SUPPLY	4
4. MEASUREMENT	5
4-1. PREPARATION	5
4-2. EXECUTION OF AUTOMATIC ZERO	5
4-3. MEASUREMENT	5
5. AUTO ZERO (A/Z)	6
5-1. SPECIFICATIONS	6
5-2. EQUIVALENT CIRCUIT OF THE EXTERNAL AUTO ZERO INPUT	6
5-3. FUNCTION.....	6
6. CHECK FUNCTION	7
6-1. SPECIFICATIONS	7
6-2. EQUIVALENT CIRCUIT OF EXTERNAL CHECK INPUT.....	7
6-3. FUNCTION.....	7
7. TROUBLE SHOOTING	8
7-1. EXECUTE TROUBLE SHOOTING.....	8
8. SPECIFICATIONS	11
8-1. SPECIFICATIONS	11
8-2. GENERAL SPECIFICATIONS	11
8-3. ACCESSORIES	11

9. WARRANTY AND REPAIR..... 12

9-1. WARRANTY.....12

9-2. REPAIR.....12

1. General

This instrument is a transmitter for tie-bar gage ($350\ \Omega$ type / two pieces set).

2. Each name and function

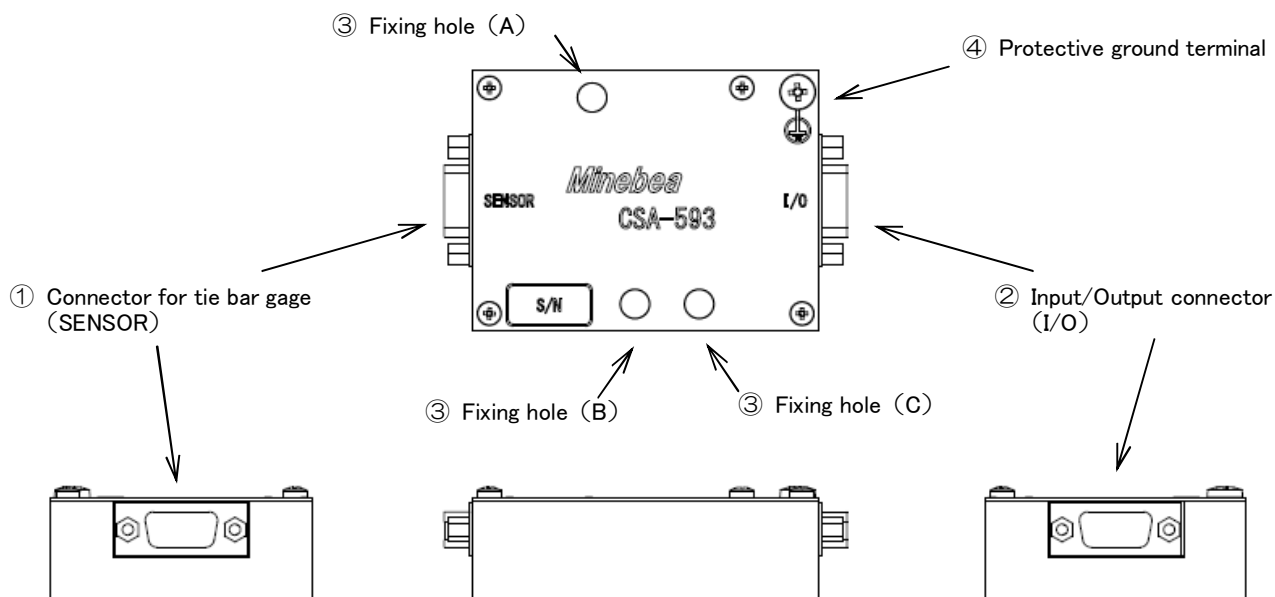

(3) Connector for tie-bar gage (for SENSOR)

Connect a tie-bar gage through connector.

(4) I/O connector (I/O)

Connect a power supply and Input/Output cable through a connector.

(5) Main body fixation hole

This is a hole to fix a unit. M6 screw is used for fixture.

Please fix by main body fixation hole (A) and (C) usually.

(* The screw for fixation is not attached. Please prepare the threaded hole processing on the installatin side.)

(6) Protective ground terminal

Please ground this unit to prevent the noise such as static electricity. Please do not connect this terminal other than the earthing conductor.

This terminal is common with the shielded terminal of a connector for tie-bar gage internally.

3. Wiring

3-1. Note for connecting wires

Caution

Please keep the following each item when you connect CSA-593. If neglected, it might cause an unexpected breakdown and damage.

- When connecting wires, turn off the power supply without fail.
- Do not supply the electric power until the installation is completed. There is no switch that switches ON/OFF of power supply in the CSA-593.
- Please separate the cable connected with CSA-593 from the noise source such as I/O for the control, power supply line as much as possible.
- The tightening torque of protective ground terminal is showing below table.

Terminal board	Tightening torque of terminal screw
Protective ground terminal	1.4 N·m

- Please execute all wirings surely according to this instruction manual.

3-2. Allocation of connector

The pin allocation of connected each signal is shown as follows:

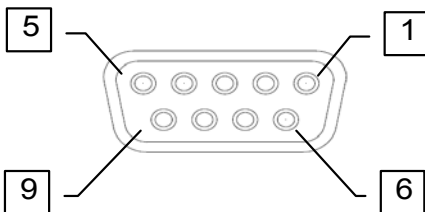

* Figure of a connector for tie-bar gage seen from uniting side. (Socket side insert)

Connector for tie-bar gage (SENSOR)

Pin No.	Name	Usage
1	A	Tie-bar gage
2	B	Tie-bar gage
3	B'	Tie-bar gage
4	D	Tie-bar gage
5	D'	Tie-bar gage
6	Shield	Tie-bar gage
7	C	Tie-bar gage
8	N.C.	No use
9	Shield	Tie-bar gage

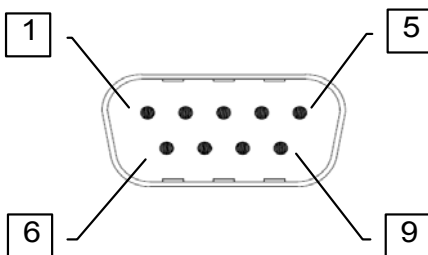

* Figure of a I/O connector seen from uniting side. (Pin side insert)

I/O connector (I/O)

Pin No.	Name	Usage
1	+24V	DC24 V
2	V-OUT+	Voltage output
3	V-OUT-	
4	for adjustment 1	No use
5	for adjustment 2	
6	+24V COM	DC24 V (Common)
7	A/Z	Input of Auto Zero
8	CHECK	Input of Check
9	COM	Common for A/Z and Check

Suitable plug (for I/O connector) : Equivalent to DE-9SF-N (JAE)

- Connector plug is not attached.
- The screw for fixing base is inch type thread.
- Don't connect with N.C. pin, adjustment 1 and adjustment 2.
- The recommended connector cover is DE-C4-J6(JAE) or equivalent. The connector cover except this may interfere with each other



When you want to raise the endurance rate to EMC, I/O connector cover is recommended to use metallic.

3-3. Wiring

Connector for tie-bar gage (SENSOR)

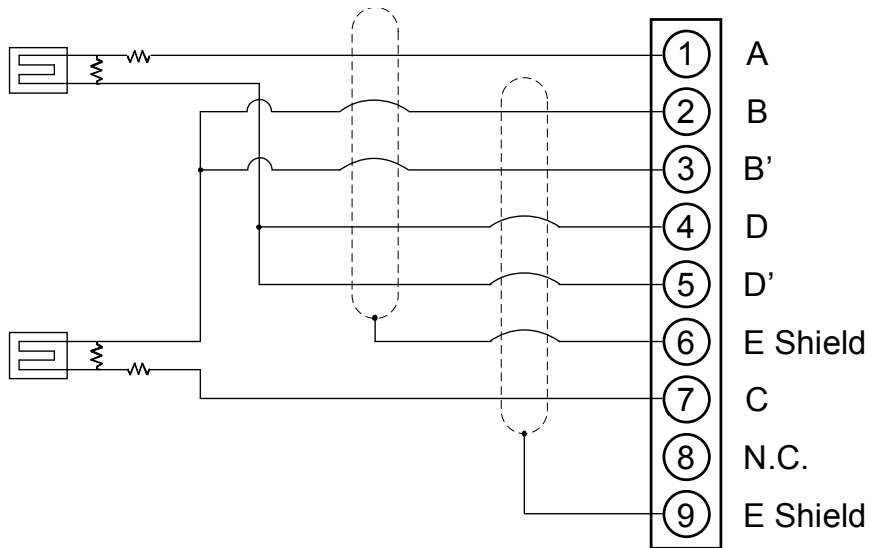

Connector for input and output (I/O).

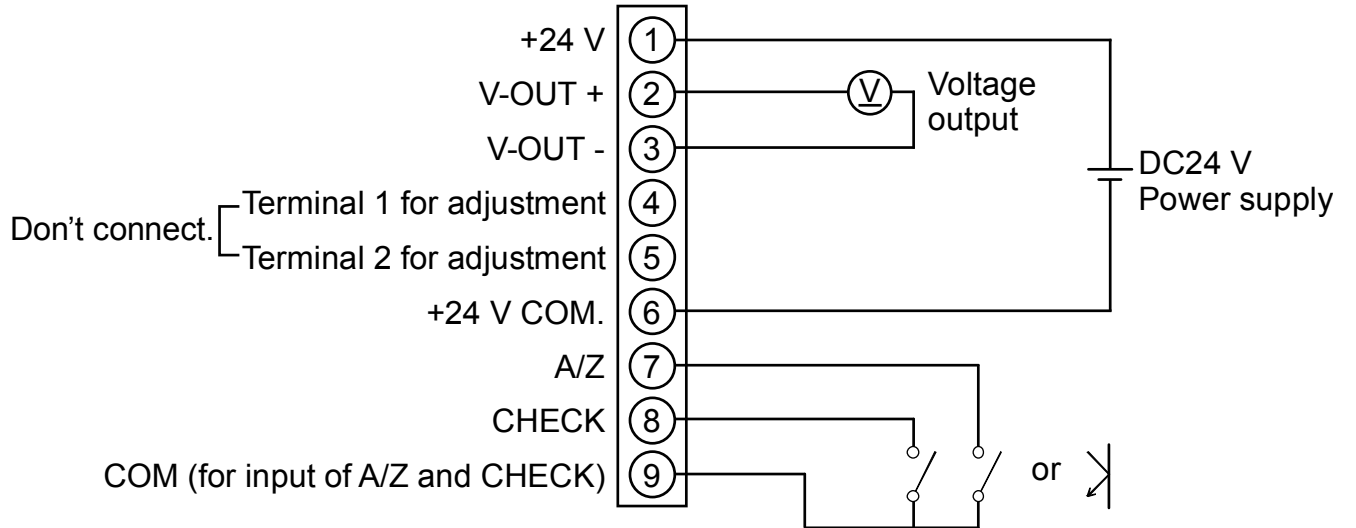

Caution

Please execute the wiring of external control input as shown in the figures. If neglected, it may cause unexpected damage or misoperation.

When you want to raise the endurance rate for EMC.

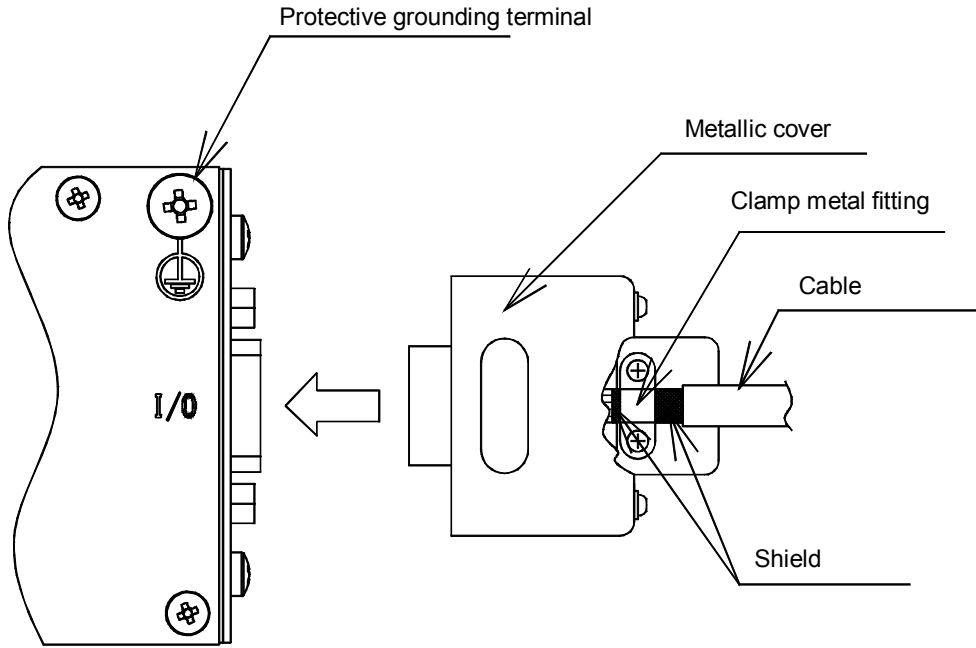

* The shield is connected with the protective ground terminal by fixing with the clamp metal fittings through a metallic cover and the I/O connector.



When you want to raise the endurance rate to EMC, the continuity of the cover and the shield is recommended to be secured by using metallic for the I/O connector cover and clamping the cable shield with metal fittings in the cover.

3-4. Connection of power supply

The power supply voltage and power consumption of CSA-593 is as follows:

Power supply voltage	DC24 V (Permissible variable range: DC20 V ~ 26 V)
Power consumption	Within approx. 50 mA (at DC24 V)

Caution

Please execute the connection of power supply surely, and use within the specified power condition. If neglected, it may cause the unexpected trouble.

4. Measurement

4-1. Preparation

The tie-bar gage is mounted to a tie bar according to the installation manual.

Please mount the tie-bar gage and connect with the I/O terminal of CSA-593 correctly according to [3. Wiring], and turn on the power.

4-2. Execution of automatic ZERO

Please make sure to reset the output voltage by using A/Z (Automatic ZERO set) before the measurement.



The lower or upper limit of output voltage in the product specification might be output in the initial strain condition at the first mounting on tie bar because ZERO calibration at the shipment of tie-bar gage is executed without mounting it on tie bar.

4-3. Measurement

CSA-593 becomes possible to measure after the execution of ZERO set, because SPAN calibration of CSA-593 is executed at the shipment. The relation between the input range and output voltage is shown in the below table.

Input ($\times 10^{-6}$ strain)	Output voltage (V)
+500	10
0	0
-500	-10



The output of tie-bar gage has the fluctuation element after turning on the power. Please use CSA-593 after about 30 minutes has passed from turning on the power to work in stable condition.

5. Auto ZERO (A/Z)

5-1. Specifications

- (1) Auto zero range : Approx. $\pm 3\,000 \times 10^{-6}$ strain
- (2) Auto zero required time : Approx. 60 ms
- (3) Auto zero accuracy : Within ± 5 mV



The result of auto ZERO is not retained in the electrical power failure.

5-2. Equivalent circuit of the external auto ZERO input

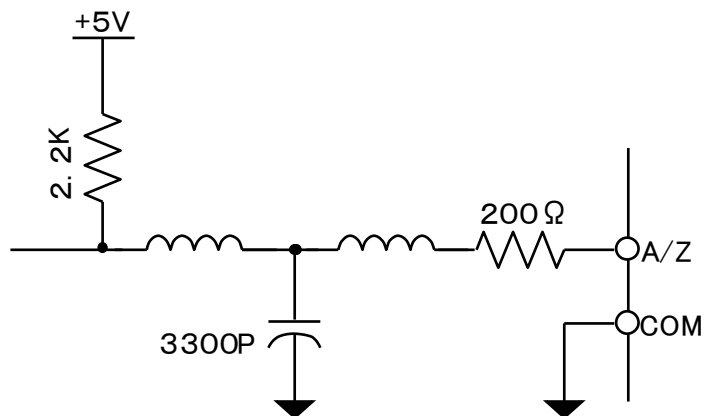

5-3. Function

- (1) The auto ZERO function works by shortening of circuit for about 50 ms or more between the external A/Z and COM, and the voltage output value becomes [0] (zero) after about 10 ms. However, the measurement of auto ZERO changes depending on the input condition (turbulence, etc.)



Please confirm the timing at the change with a CSA-593 itself when the condition changes in the external control, and match the timing if necessary by the timer processing.

6. Check function

6-1. Specifications

(1) Output of check :Approx. 5 V



The check function is used for maintenance.

6-2. Equivalent circuit of external check input

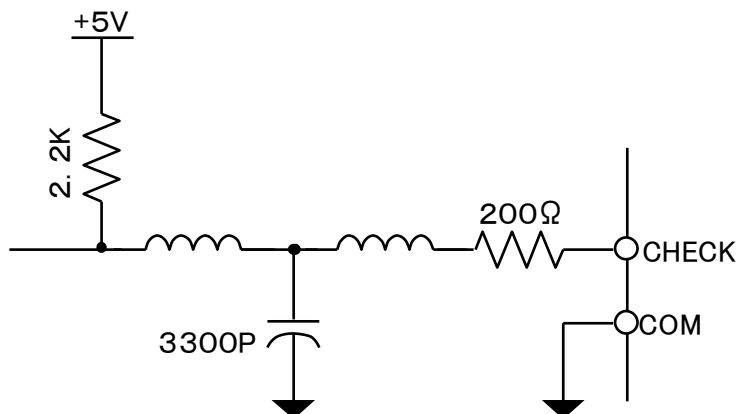

6-3. Function

The voltage output becomes DC+5 V while shortening the circuit between external CHECK⇔COM regardless of the input condition from tie-bar gage.

7. Trouble shooting

Please confirm the contents of the reference item when the following abnormal operation exists while using CSA-593. Also, please contact with Minebea when there is no corresponding item, and when that abnormal operation is not improved even if the countermeasures are executed.

7-1. Execute trouble shooting

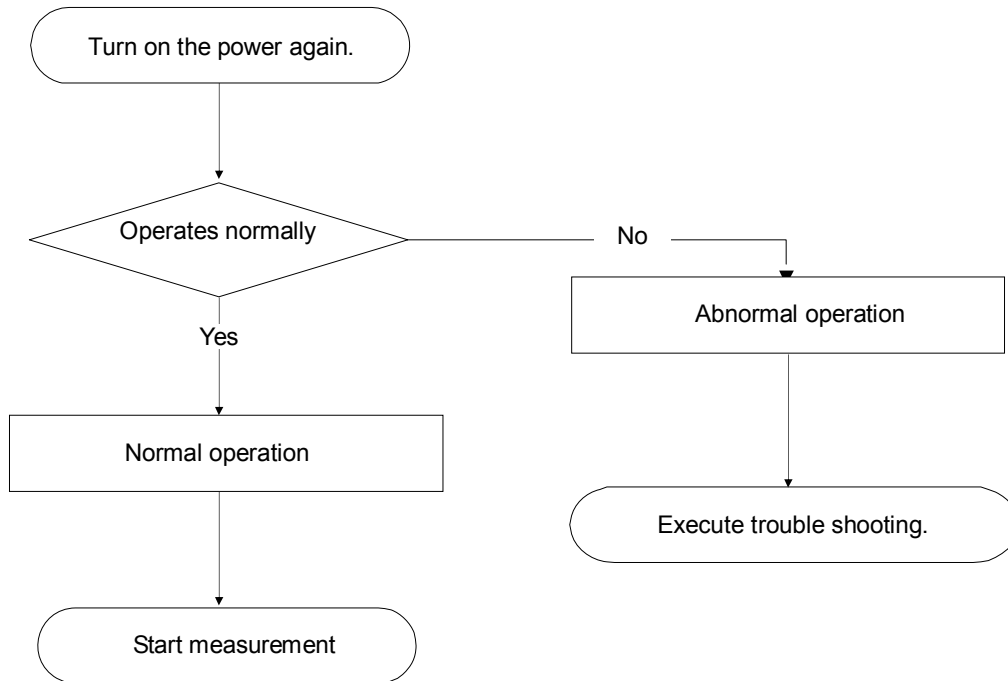

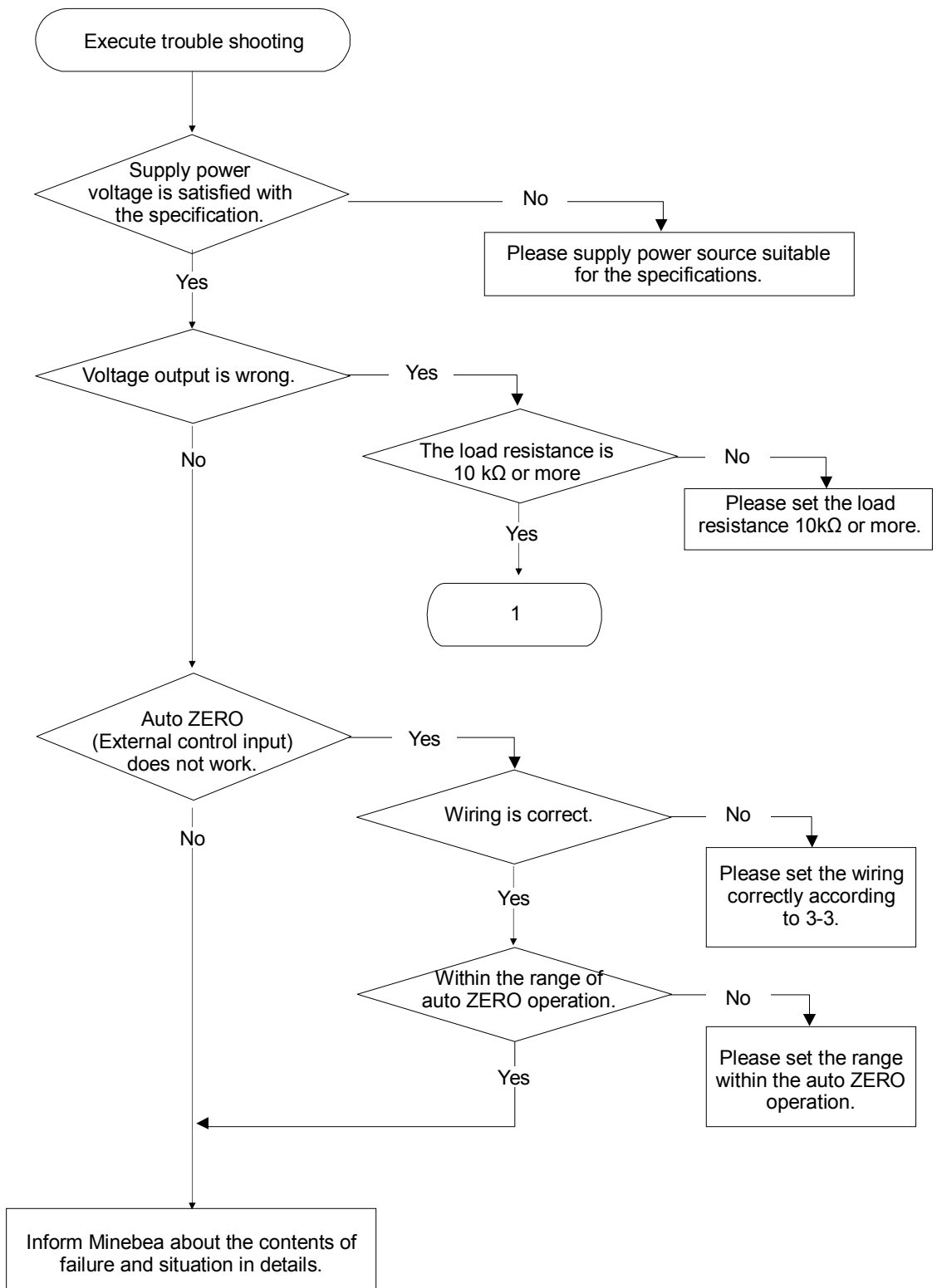

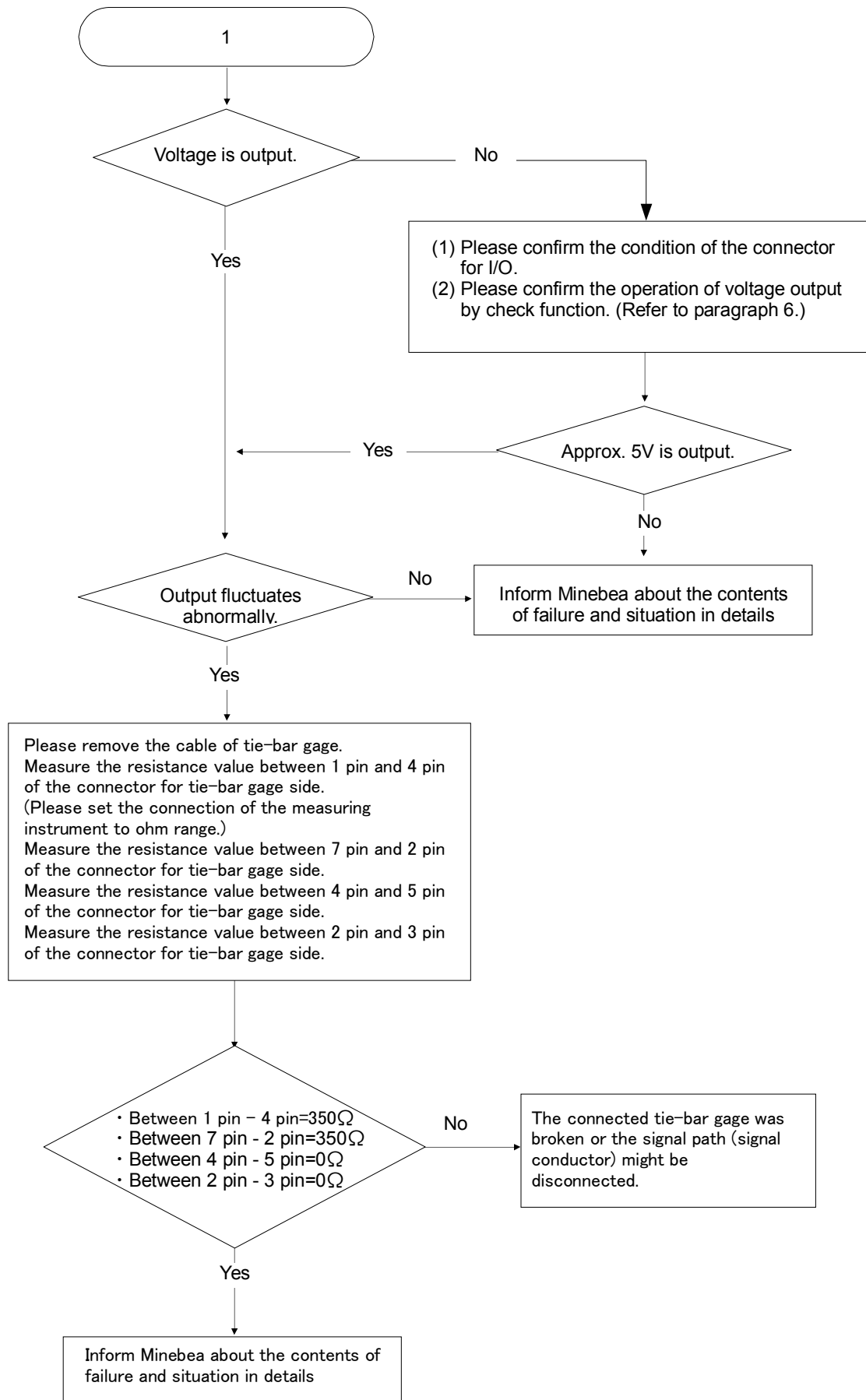

8. Specifications

8-1. Specifications

Bridge power supply	DC5 V±0.3 V within 30 mA	
Applicable transducer	1 set of tie-bar gage (350 Ω type a couple by 2 pieces)	
Input range	±500×10 ⁻⁶ strain	
Output voltage	±10 V	
Output load resistance	10 kΩ or more	
Sensitivity	10 V output at the input of 500×10 ⁻⁶ strain	
Non-linearity	0.02 %F.S. (Only for transmitter)	
Temperature coefficient	ZERO	±10 μV/°C (Input conversion)
	Sensitivity	±0.05 %F.S./°C
Frequency response range	Approx. 100 Hz (Fixed)	
A/D sampling rate	2 000 times/s	
A/D internal resolution	24 bit	
Output rate	2 000 times/s (Synchronous with A/D sampling rate)	
Output resolution	Approx. 1/10 000	
Automatic ZERO range	Approx. ±3 000×10 ⁻⁶ strain	
Required time for automatic ZERO	Approx. 60 ms	
Accuracy of automatic ZERO	Within ±5 mV	
Output for check	Approx. 5 V	

8-2. General specifications

Operating temperature range	-10 °C ~ 70 °C
	80 %RH or less (Non condensing)
Power supply voltage	DC24 V (Permissible variable range : DC20 V ~ DC26 V)
Power consumption	Within approx. 50 mA (at DC24 V)
Outline dimensions (W×H×D)	81 mm × 61 mm × 24.5 mm (Excludes protruding parts, and connector.)
Weight	Approx. 0.5 kg

8-3. Accessories

Instruction manual	1 pad
--------------------	-------

9. Warranty and Repair

9-1. Warranty

CSA-593 is covered by a warranty for a period of one year from the date of delivery.

Please contact with Minebea's sales office or sales agent from whom you have purchased as for repairs and/or after service is required during the period of warranty.

9-2. Repair

Before asking repairs, please check once again that the connection, the setting and the adjustment for the instrument have finished properly.

As a result of checking, still there may have some defects in the instrument, please contact with Minebea's sales office or sales agency from which you have purchased.

- The contents of this manual may subject to change without notice.

HEAD QUARTER : **MINEBEA CO., LTD.**

4106-73 Miyota, Miyota-machi, Kitasakugun, Nagano-ken 389-0293, Japan

☎0267-32-2200 FAX.0267-31-1350

Measuring Components Business Unit

FUJISAWA PLANT 1-1-1, Katase, Fujisawa-shi Kanagawa-ken, 251-8531 Japan

☎0466-22-7152 FAX.0466-22-1701

KARUIZAWA PLANT 4106-73 Miyota, Miyota-machi, Kitasakugun, Nagano-ken 389-0293, Japan

☎0267-31-1309 FAX.0267-31-1350

HOME PAGE ADDRESS <http://www.minebea-mcd.com>