

BKL5

2023/03/22

Overview



3 Phase outer rotor type DC Brushless Motor

Bearing : Can select Oil retaining bearing or Ball bearing

Connection : On request basis

Detent torque : It is possible to adjust the detent torque upon request.

Interface : Coil terminal

Input & Output of Hall sensor or Hall IC

Circuit : Can respond to the mounting of the drive IC

Shaft : It is possible to respond to the change of length, the shape of D-cut, the addition of the gear, etc..

Shaft output direction can be selected up and down.

Overall View

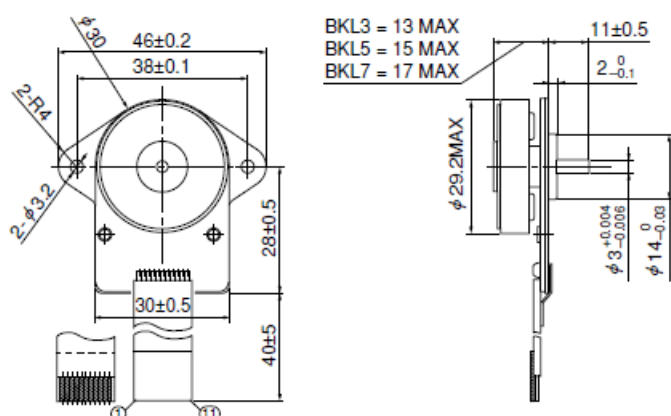

BKL5

2023/03/22

Specification

Outer Diameter [mm]	No load speed [r/min]	Starting torque [mN · m]	Maximum output power [W]	Starting current [mA]	Starting torque [%]	Speed at maximal efficiency [r/min]
29.2	4000	38.0	4.1	1400	69	3300

Speed at max output power [r/min]	Life at 20 deg.C [hour]
1900	5000

* Major characteristic parameters at 12V.

Please contact our sales for detail specification & order lot QTY. (All custom product by customer's requirement)

Property diagram

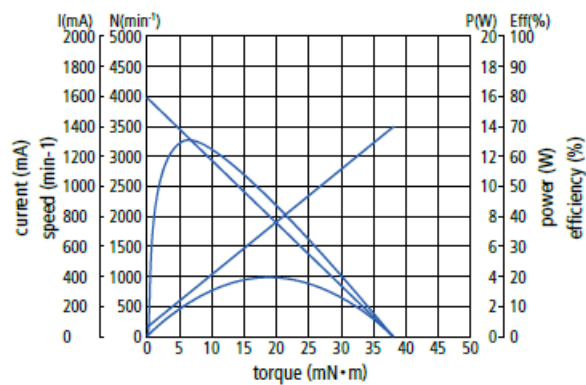

※ Adjustable by winding